

August 2000, as of version 7.0

User's Manual for Stand Alone 2 Powder with concentrate and scales

TAP2-SA2-KFA-75-P
TAP2-SA2-KFA-50-P
TAP1-SA2-KFA-38-P
TAP1-SA2-KFA-32-P
TAP1-SA2-KFA-30-P
TAP1-SA2-KFA-28-P
TAP1-SA2-KFA-27-F

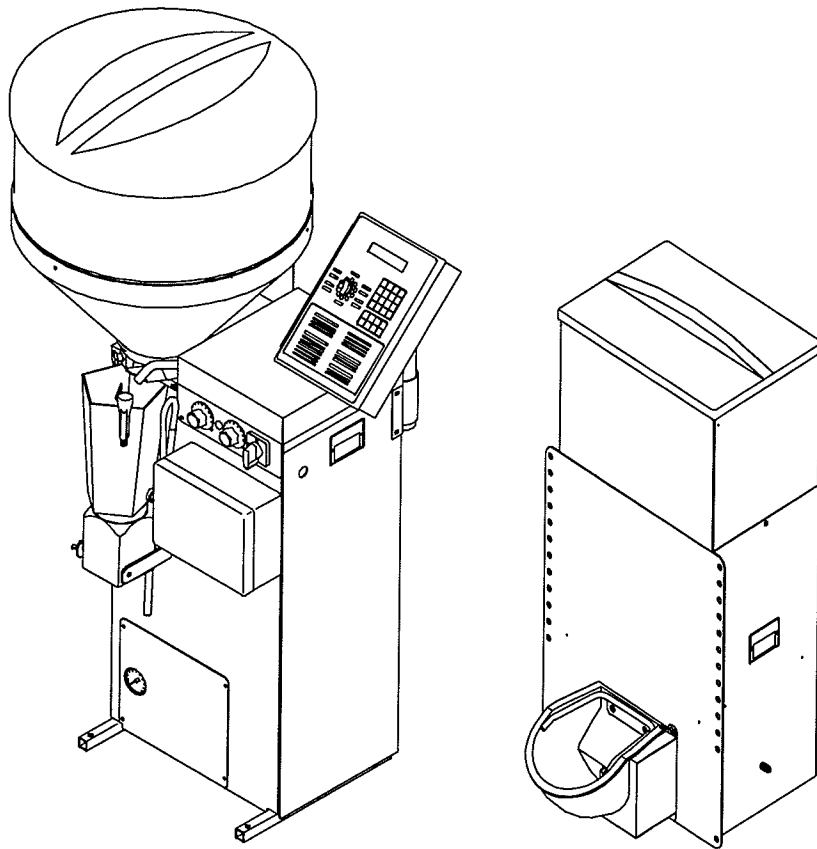

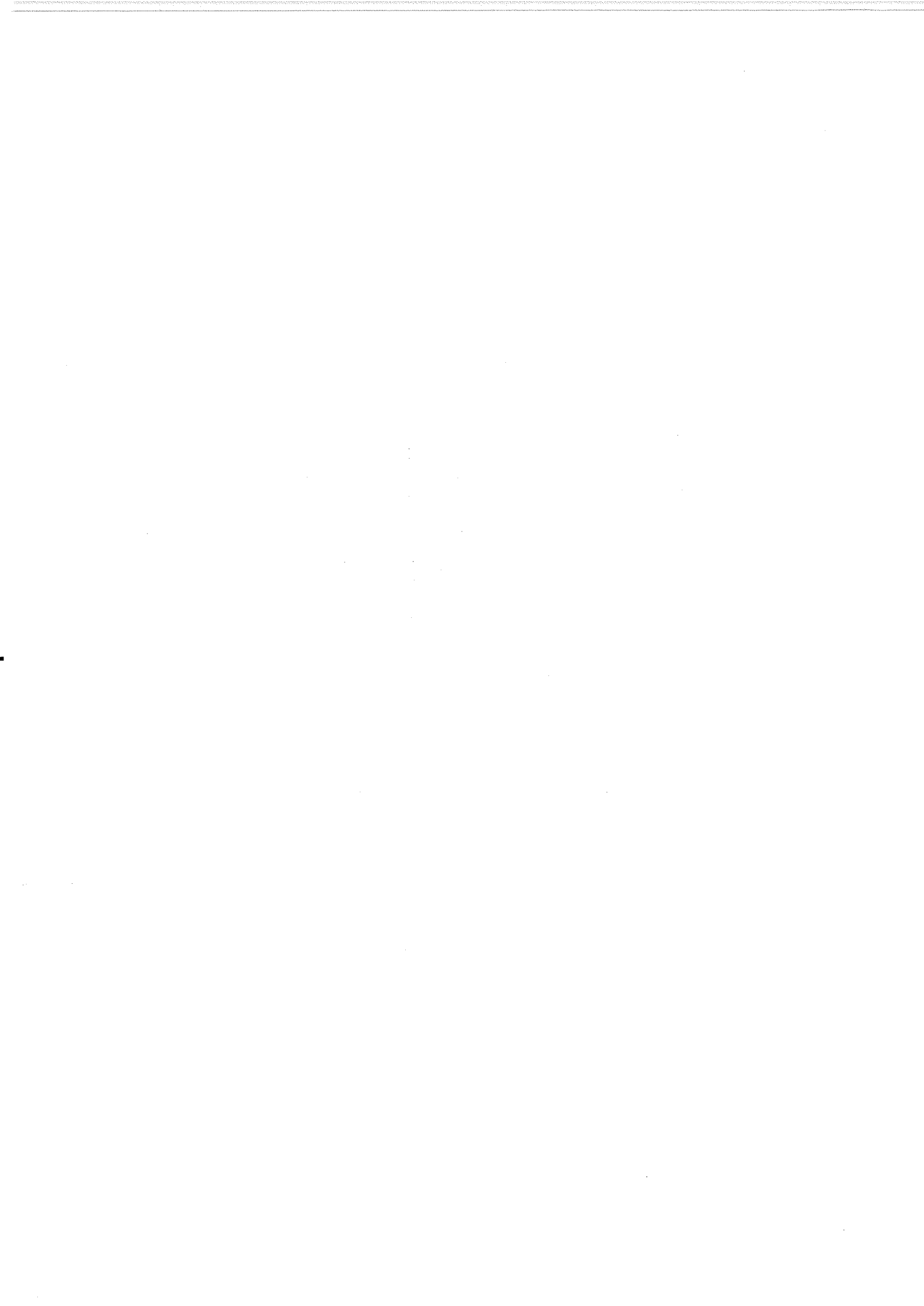

1	Introduction	7
1.1	Guidelines for the user's manual	7
1.2	Safety instructions	8
1.3	Construction parts Stand Alone Powder	9
1.3.1	Control – Power supply unit Powder	10
1.3.2	Water heating in the boiler	11
1.3.3	Accessories (not shown)	11
1.3.4	Hand-actuated feeding pump	12
1.4	Construction Parts Concentrate Feeder	13
1.5	Technical data automatic calf feeder	15
2	Specifications Concentrate Feeder	16
3	Location of the automatic calf feeder	17
3.1	Local electrical connection	17
3.2	Installation of the automatic calf feeder	17
3.3	Mounting the sucking station	18
3.4	Mounting the race-way	19
3.5	Connection micro-identification	20
3.5.1	Identification „Mikro-Nedap“	20
3.5.2	Identification „Mikro-Tiris“	20
3.6	Mounting the top section of the milk powder hopper	21
3.7	Water connection	22
4	Location of the concentrate feeder	23
4.1	Mounting the concentrate feeder	23
4.2	Filling of the concentrate feeder	24
4.3	Connecting the mains plug	24
4.4	Checking and setting the dosing flap	24
5	Installation of the automatic calf feeder	26
5.1	Connecting the mains plug of the automatic calf feeder	26
5.2	Filling the boiler with water	26
5.3	Filling the powder hopper with milk powder	26
5.4	Operating and Control unit	27
5.4.1	Operating unit with processor and power supply unit	27
5.4.2	Operational controls	28
5.4.2.1	Program switch and switch menu	28
5.4.2.2	Keyboard and keyboard menu	28
5.4.2.3	Hand-operation keys	31
5.5	Entering routine	32
5.5.1	Exercises for the switch menus	33
5.5.2	Exercise for the keyboard menus	33
5.6	Basic settings during installation	34
5.6.1	Checking date/time	34
5.6.2	Carrying out new installation	34
5.7	Setup	36
5.7.1	Activating the concentrate	36
5.7.2	Setting the baud rate for PC and concentrate feeder	37
5.7.3	Selecting the printing function	38
5.7.4	Selecting the animal scales	39
5.7.5	Carrying out interface test	41
5.7.6	Registering and cancelling feeding stations	41

5.7.7	Setting distribution pause	42
5.7.8	Mixer: Activating the cleaning system (time-controlled)	43
5.7.9	Selecting the retractable teat	43
5.7.10	Hose pipe cleaning	44
5.7.11	Mixer: Activating the cleaning system (time-controlled)	44
5.7.12	Selecting the retractable teat	46
5.7.13	Hose pipe cleaning	46
5.8	Connection test towards concentrate feeder	47
5.9	Calibration	48
5.9.1	Calibrate water and MP	48
5.9.2	Calibrate additives	49
5.9.3	Calibration of concentrate	51
5.10	Setting the heating	52
5.10.1	Setting the thermostats	52
5.10.2	Recommendations for temperature settings	53
5.10.3	Measuring the temperature	53
5.11	Animal identification and Responder number input	54
5.11.1	Animal identification	54
5.11.2	Check connection between micro-identification and Stand Alone	55
5.11.3	Automatic reading of the Responder number and Antenna test	55
5.11.4	Manual input of Responder numbers	56
5.12	Registration of animals	57
5.12.1	Registration of individual animals	57
5.12.2	Registration of groups	59
5.12.3	Automatic registration	60
5.13	Entering correction days	61
5.14	Entering deviations	62
5.14.1	Deviations of drinking portions	62
5.14.2	Deviations of concentration	63
5.14.3	Deviations of concentrate	63
5.14.4	Deviations of powdery additives	64
5.14.5	Deviations of liquid additives	65
5.15	Accustoming aid	66
6	Altering Operational Data	68
6.1	Feeding plans	68
6.1.1	Age-dependent drinking	68
6.1.2	Concentrate-dependent feeding	70
6.2	Concentration plans	72
6.3	Concentrate plans	73
6.4	Entitlement intervals	75
6.4.1	Feeding intervals	75
6.4.2	Concentrate intervals	76
6.5	Quantity limits	77
6.5.1	Minimum saved quantity and Maximum quantity for drinking	78
6.5.2	Carry over of the drinking	79
6.5.3	Quantity limits for concentrate	80
6.5.4	Carry over of the concentrate	81
6.6	Warning levels	82
6.6.1	Warning levels for feeding	82
6.6.2	Warning levels for concentrate	83
6.7	Equipment data: station number	85
6.8	Restricted/Ad Libitum mode	86

6.8.1	Restricted/ad libitum – mode on automatic calf feeder	86
6.8.2	Restricted/ad libitum mode on concentrate feeders	87
7	Functioning of automatic calf feeder and concentrate feeder	88
7.1	Preparation of drinking portions	89
7.2	Drinking distribution	89
7.2.1	In Restricted mode	89
7.2.2	In ad lib mode	90
7.3	Distribution of concentrate	90
7.3.1	Restricted mode	90
7.3.2	Ad lib mode	90
7.4	Release of an extra portion	91
7.4.1	Long sensor free	91
7.4.2	Long sensor covered	92
7.5	Feed delay/Delete demand	93
7.5.1	Delete feed delay	93
7.5.2	Delete demand for the entire group	94
7.5.3	Delete demand for one animal	94
7.6	Daily calculation	95
8	Check functions	96
8.1	Displays on switch position „Feeding Mode“	96
8.2	Animal verification	97
8.2.1	Calves with right	97
8.2.2	Feeding behaviour	98
8.2.3	C1 and C2	99
8.2.4	Animal verification C1	99
8.2.5	Animal verification C2	100
8.2.6	Visit and robbery	100
8.2.7	Animal scales	100
8.2.8	Number of animals	101
8.3	Warnings	102
8.3.1	Drinking warnings	102
8.3.2	Breaks	103
8.3.3	Feeding speed	103
8.3.4	Robbers	104
8.3.5	Additive warning	104
8.3.6	Unknown Responders	104
8.4	Concentrate warnings	105
8.5	Dates of expiry	106
8.6	Animal data and Info	108
8.6.1	Weight, Feeding days	108
8.6.2	Daily ration/animal	110
8.6.3	Cancellation	111
8.6.4	Change registration of animals	112
8.7	Consumption	113
8.8	Consumption totals	114
9	Cleaning	115
9.1	Mixer cleaning (mixer without automatic cleaning)	115
9.2	Automatic mixer cleaning (time-controlled)	116
9.3	Call up Automatic mixer cleaning manually	117
10	Service and maintenance	118
10.1	Service and maintenance of the automatic calf feeder	118

10.1.1	The day after the first starting	119
10.1.2	Carry out a regular check routine	119
10.1.3	Shut-down	120
10.2	Service and maintenance of the concentrate feeder	121
11	List printing	122
12	Error messages	123
12.1	Check the calibration values for drinking	123
12.2	Feeding interrupted	123
12.3	Data destroyed	123
12.4	Water shortage	124
12.5	Clean alerts	124
12.6	Mains interruptions/Restoring from backup/Water checks	125
12.7	Error in concentrate mode and with scales connection	126
12.7.1	Connection errors	126
12.7.2	Check the calibration values for concentrate	126
12.7.3	Idle shaft	127
12.7.4	Shaft is blocked	127
13	Additives	128
13.1	Entry of additive plans and prescriptions	131
13.1.1	A/Po-plan	131
13.1.2	A/Li-Plan	132
13.1.3	Prescriptions	132
13.2	Activation of the additive dispense	134
13.2.1	A/Po individual	134
13.2.2	A/Po group	135
13.2.3	A/Li individual	136
13.2.4	A/Li group	136
13.2.5	Block on remaining portion	137
13.2.6	Prophylaxis	137
13.2.7	Info	138
14	Animal scales	139
14.1	Checking connection, taring animal scales, carrying out weighing	139
15	Accessories	141
15.1	Two-group valve unit	141
15.2	Additive dispenser	142
15.3	Pilot lamp box for Stand Alone automatic calf feeder	143
	Declaration of Conformity	A
	Connection between Printer and Stand Alone	B
	Feeding plan group A	C
	Feeding plan group B	D
	Feeding plan group C	E
	Feeding plan group D	F
	Form: Feeding plan	G
	Form: Concentration plan	H

1 Introduction

1.1 Guidelines for the user's manual

For a better understanding of the user's manual graphic symbols are used.



Attention: absolutely observe the contents of the user's manual, to avoid injury and damage to persons, animals and appliance.



Symbol for important instructions and additional explanations to operate the feeder.



Symbol for examples in the user's manual.



This symbol requires entry of a figure in the corresponding menu.

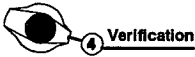

Additional reading assistance, when program switch has to be operated, e.g. to select a switch menu.



Symbol for measuring cylinder for collecting and weighing the feed components.



Symbol for scales used to weigh the feeding components during calibration procedure.



Symbol for thermometer to measure the body temperature.



Symbol for collar with identification system.

1.2 Safety instructions

- Installation of the automatic feeder must be carried out by qualified personnel.
- Before starting the machine, read the user's manual carefully.
- Proper installation and operation as well as care and maintenance of the automatic calf feeder are conditions for its faultless functioning.
- Unclear or erroneous data entries may have grave consequences. Therefore, all data should be checked as to their proper content, before entering them.
- The livestock owner is responsible for a steady and scrupulous control of his animals and the functioning of the automatic calf feeder. If, for any reason, the system should break down or some calves should not make use of it, the owner has to choose other feeding methods for those animals.
- The manufacturer accepts no liability for damages and their consequences, caused by wrong installation, wrong operation, unjust treatment, poor service and maintenance or false entries.
- Remove any projecting object (e.g. pipe ends) from the stable, because Responder collars could get caught in it.
- The system is only meant to feed calves.
- You will find more safety instructions in the following chapters.

If requested, wiring diagrams and spare part lists will be made available to you.

In case you need more information, please contact us:
Förster-Technik GmbH,
Gerwigstr. 25,
D-78234 Engen,
Tel. +49 / 7733 / 9406-0,
Fax +49 / 7733 / 9406-99
Internet: www.foerster-technik.de

1.3 Construction parts Stand Alone Powder

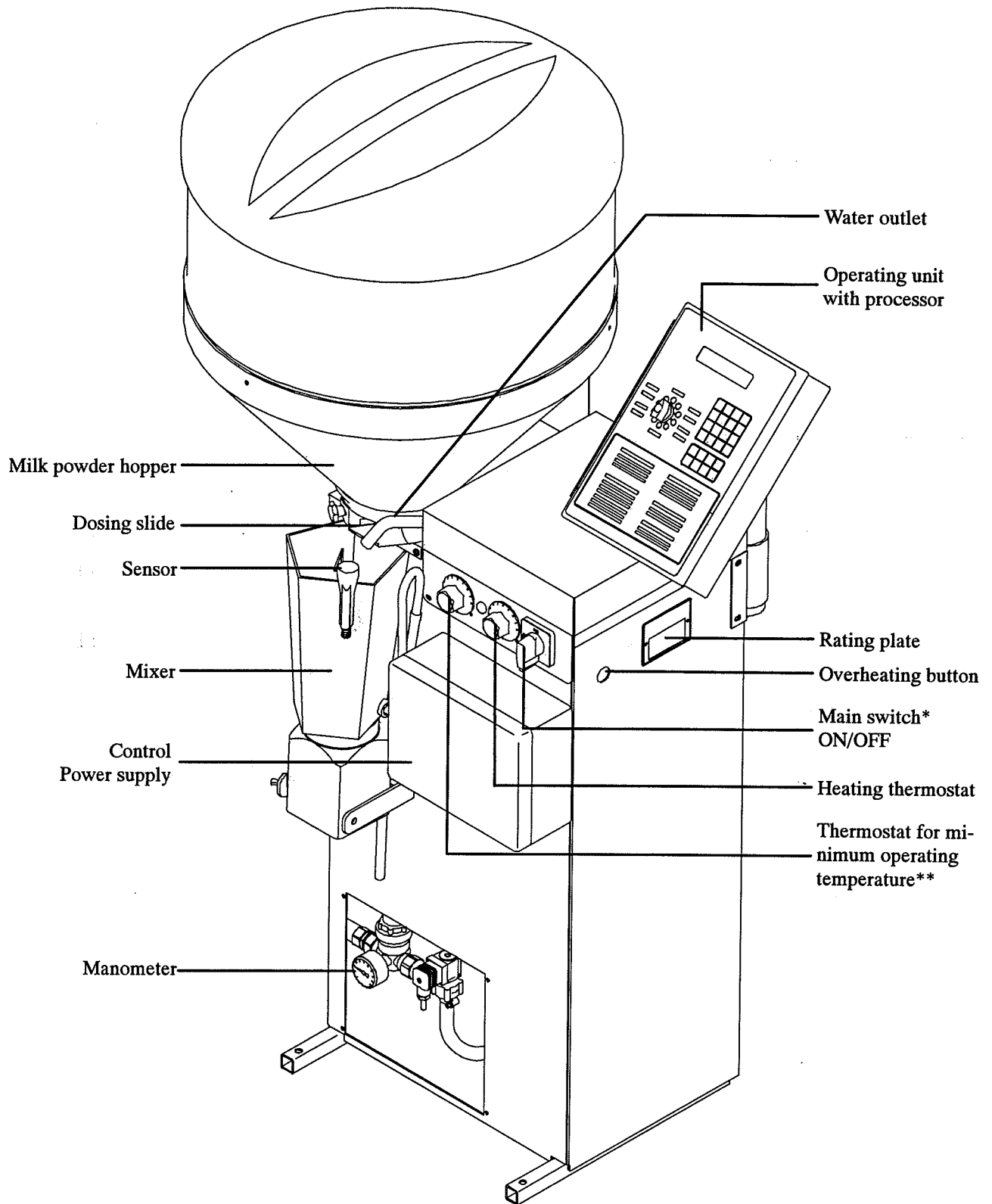

* not available on „TAP1-SA2-27-F“

** available as an option on „TAP1-SA2-27-F“

1.3.1 Control – Power supply unit Powder

On the power supply unit you can find the transformer to power the processor control, the relays as well as the sockets for external devices, the fuses and pilot lamps.

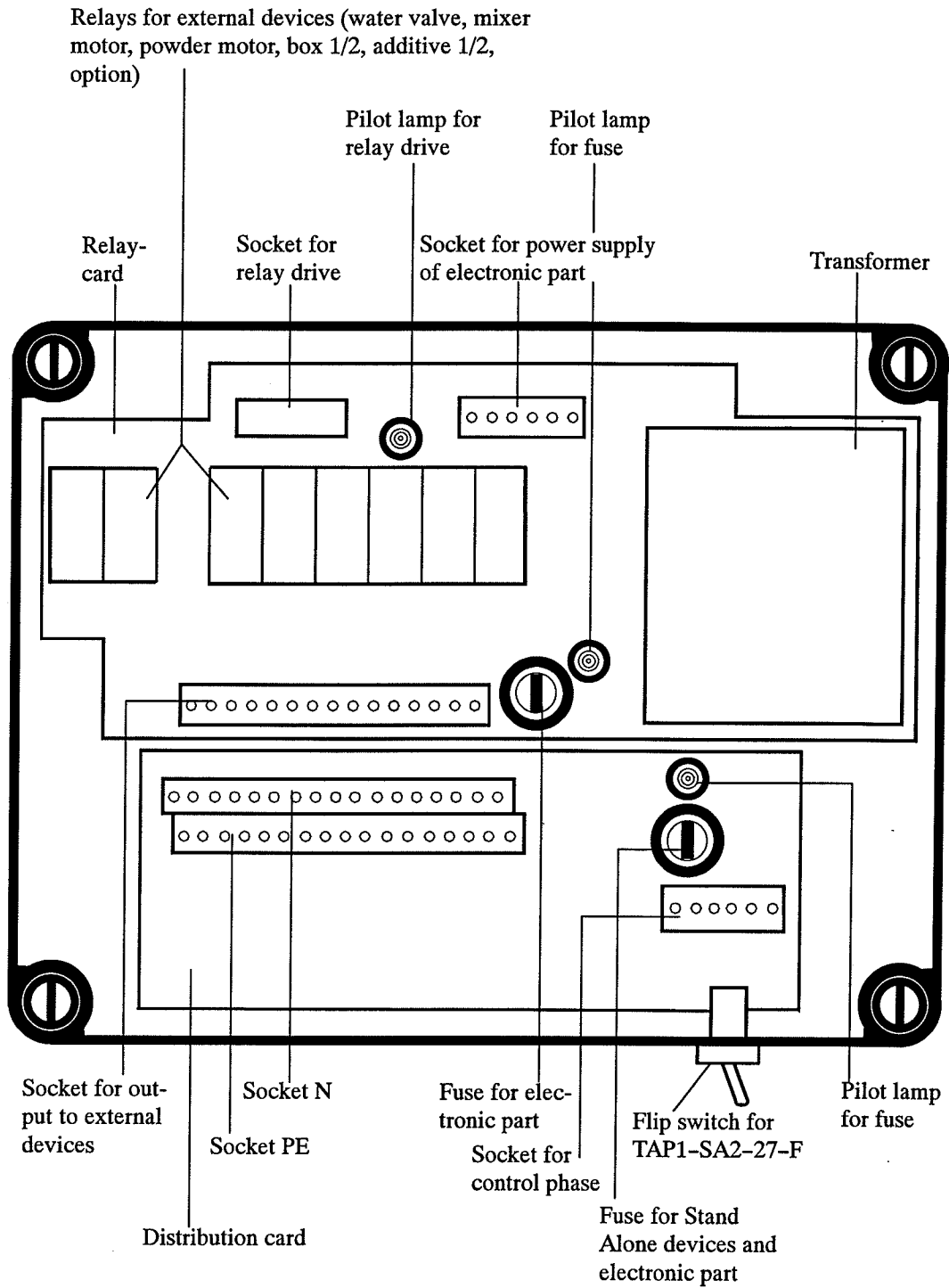

1.3.2 Water heating in the boiler

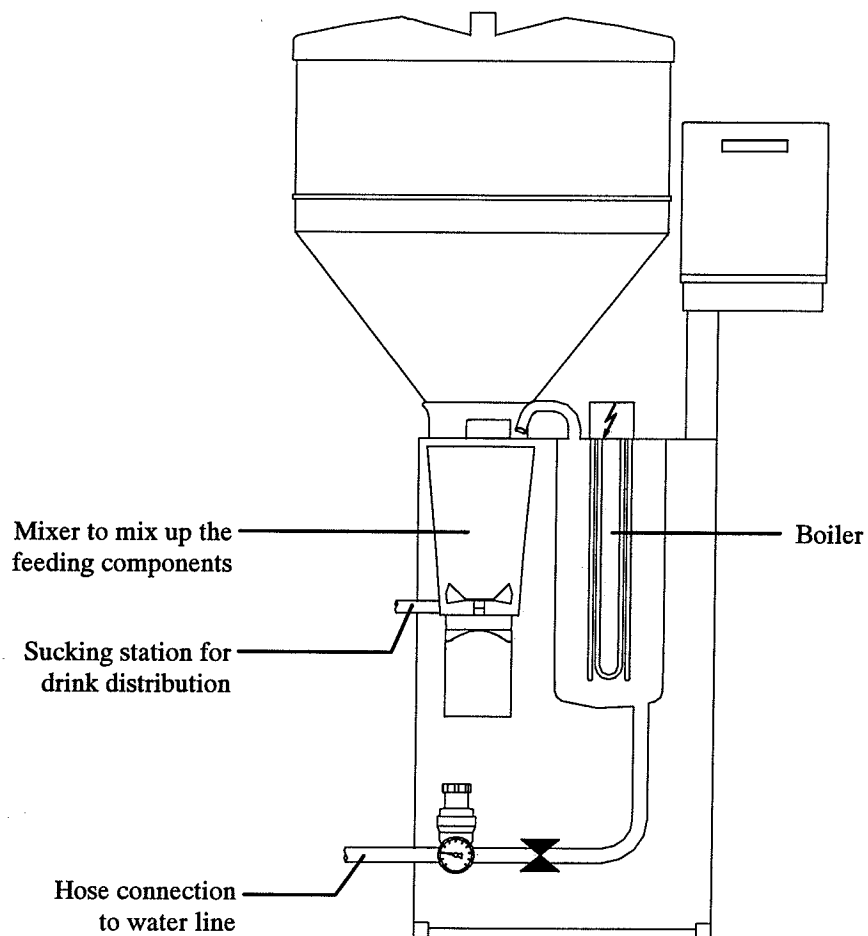

1.3.3 Accessories (not shown)

You can find more detailed information in the chapter „Accessories“.

- 2-group-valve-unit
- additive dispenser for powdery additives (cable for 1 additive dispenser is available as standard)
- additive dispenser for liquid additives (cable for 1 additive dispenser is available as standard)
- pilot lamp box with connection possibility to remote alarm

1.3.4 Hand-actuated feeding pump

The hand-actuated feeding pump supports the calf's training in using the feeding station. You can find it between mixer exit and sucking station. The feeding pump can be activated by pushing a button at the lower side of the housing or at the sucking station. The feed is then directly transported from the mixer to the teat and into the mouth of the calf respectively.

You may also use the feeding pump to discharge manually rinse water located in the mixer jar.

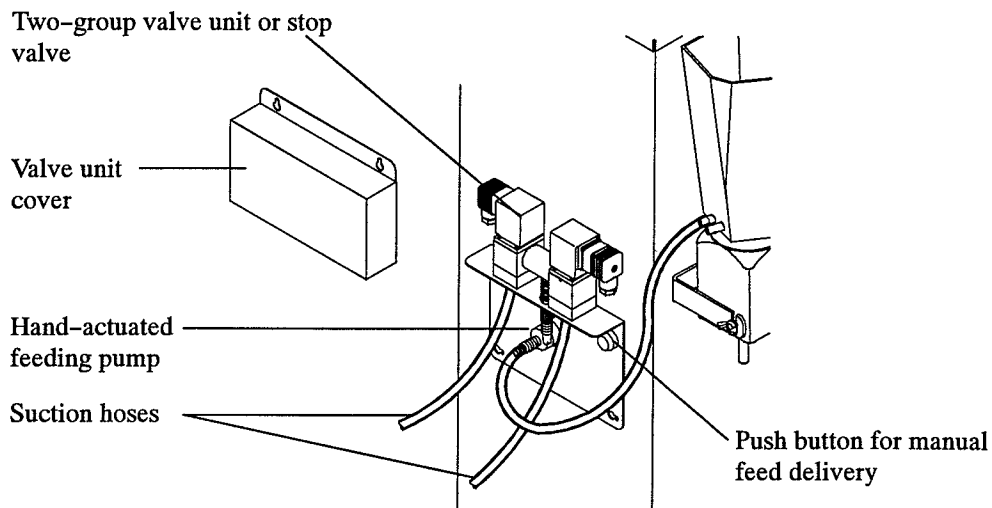

Do not clean the feeding pump with the rinse sponge. It may get clogged!

1.4 Construction Parts Concentrate Feeder

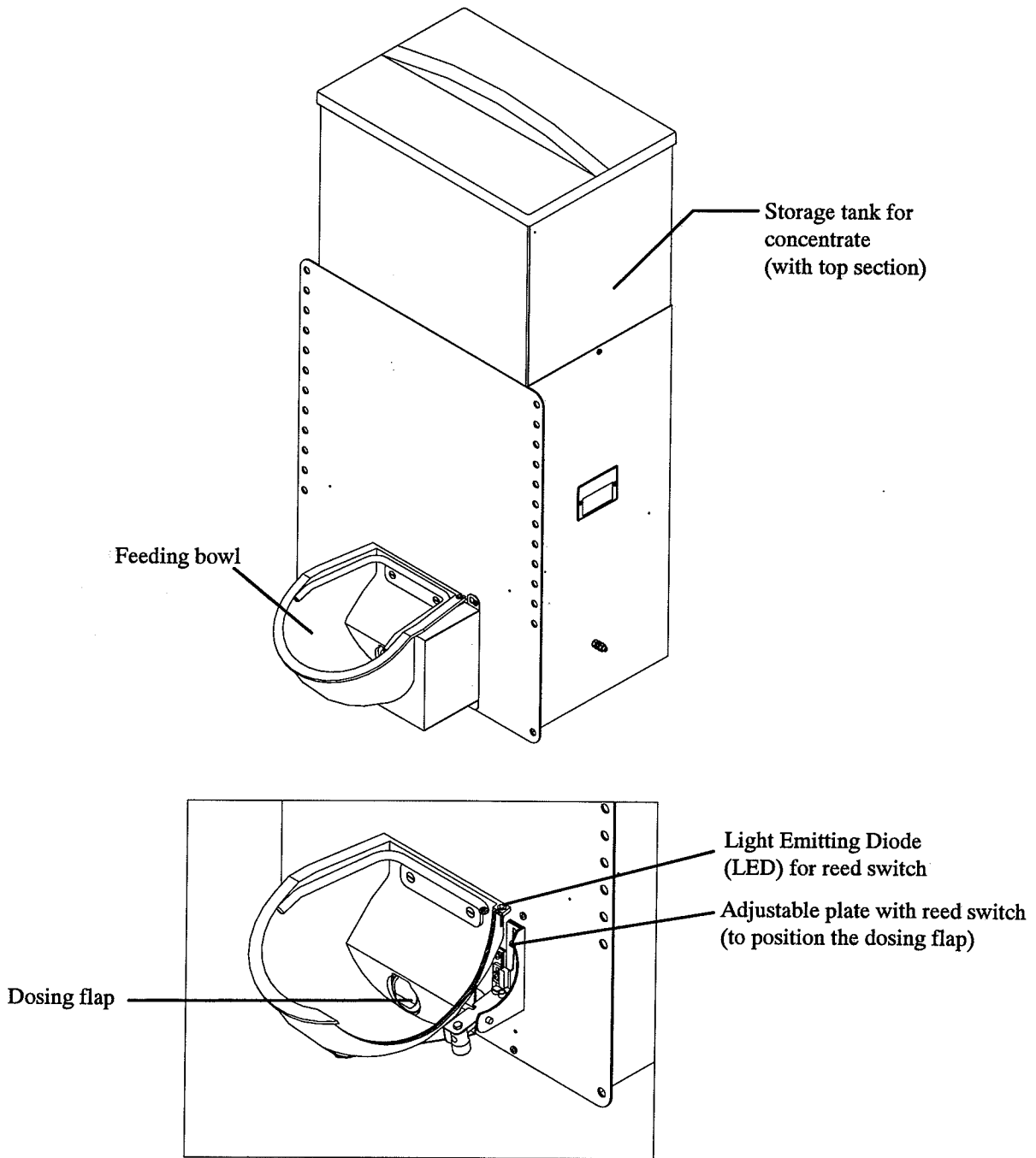

Master-control
(Control unit at the rear of the Master-Concentrate feeder)

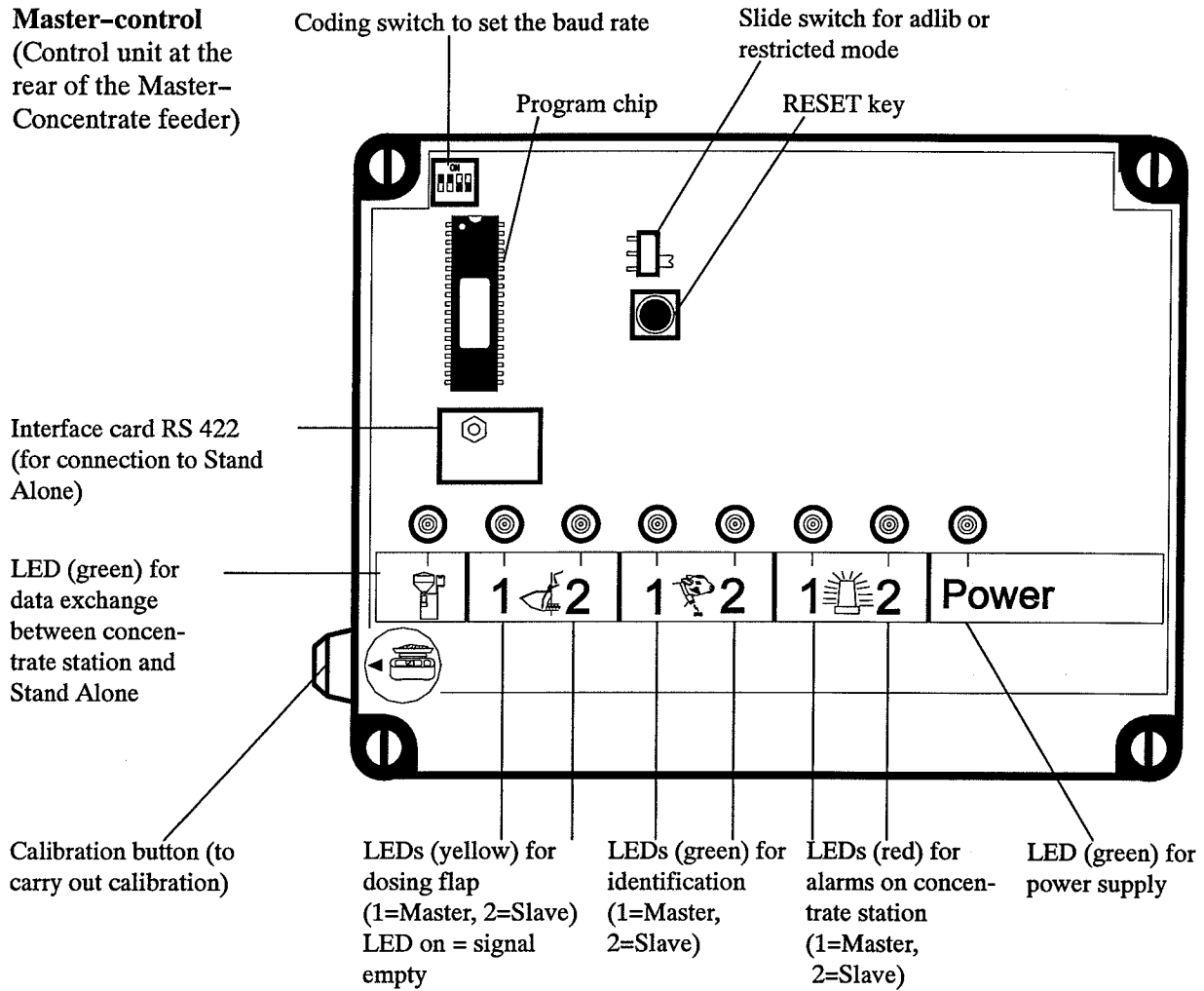

Slave-control
(at the rear of the Slave-Concentrate feeder which is controlled by the Master)

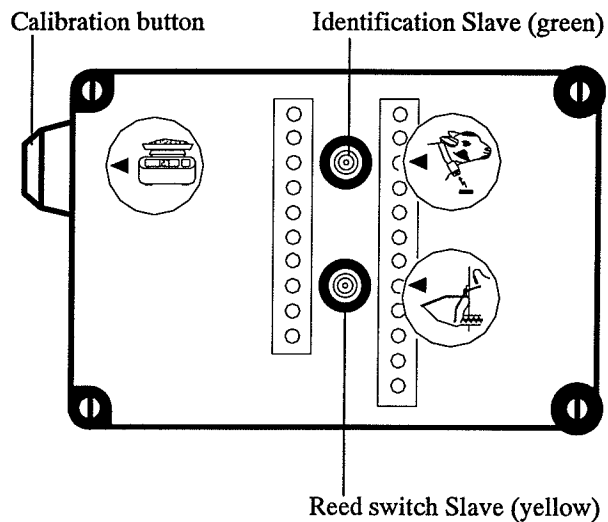

1.5 Technical data automatic calf feeder

Electrical connection

TAP2-SA2-75-P, TAP2-SA2-50-P, TAP1-SA2-38-P, TAP1-SA2-27-F (400V)

230V / 400V / 3 / N / PE, 50 Hz, 16 A

TAP1-SA2-32-P, TAP1-SA2-27-F (230V)

230V / L / N / PE, 50Hz, 16 A

TAP1-SA2-30-P

200V, 50 / 60 Hz, 20 A

TAP1-SA2-28-P, TAP1-SA2-27-F (240V)

240V / L1, L2 / Grd / 60Hz, 15 A

Water connection

1/2" hose with 3/4" hose coupling.

The local water pressure has to be between 2,5 and 6 bar.

Boiler

Boiler contents approx. 5 l

Milk powder hopper - storage capacity (with top section)

TAP1: approx. 35 kg

TAP2: approx. 55 - 120 kg (depending on top section)

Number of sucking stations and animals per station

Each calf feeder can supply approx. 20 - 30 rear calves or 15 - 20 veal calves on one sucking station. Whereas on 2 sucking stations it can supply approx. 50 - 60 rear calves, 20 - 30 veal calves or 20 rear calves and 15 veal calves.

2 Specifications Concentrate Feeder

Electrical connection

Power supply: Safety transformer according to VDE 0551
Mains voltage: 230 V/50 Hz
Output voltage: safety low voltage 24 V AC
Power: 72 VA safety class IP 54

Master: Safety low voltage 24 V AC, power consumption: 48 W

Slave: Safety low voltage 24 V AC, power consumption: 36 W

Note: The motors of the Master and Slave concentrate feeders never run together (they are mutually blocked), therefore one power supply will do for the Master as well as for the Slave.

Storage capacity of concentrate storage tank

Depending on the type of concentrate used, up to approx. 70 kg. Volume: approx. 95 l

Number of concentrate feeders and number of animals

The concentrate control unit located on the Master station can control 2 concentrate feeders, according to the Master-Slave-System. The distance between both concentrate feeders is determined by the maximum length of the antenna cable (max. 6 m). Longer distances require an additional Master station. To each Stand Alone you may connect up to 2 Master stations with one Slave station each.

Each concentrate station can provide up to 25 calves with feed. The exact number depends on the quantity of concentrate dispensed per calf.

Distance between concentrate feeder and Stand Alone



The distance between Slave station and Master station must not exceed 6 m. The real length of the antenna cable is decisive and not the immediate distance („airline“).



Specifications are subject to change without prior notice.

3 Location of the automatic calf feeder

3.1 Local electrical connection

- Local electrical connection must be installed by a qualified electrician.
- Local regulations and safety precautions must be observed. An earth leak switch (30 mA) in customer's power supply is prescribed, in order to operate the automatic calf feeder.
- The automatic calf feeder requires its own power supply: *refer to chapter 1.5, page 15, „Technical Data“*.
- Nominal voltage and Nominal frequency must be observed. The supply voltage indicated on the rating plate must correspond to the one of the electric network.
- In case of overvoltage risk, install a surge voltage protector in the main distribution unit.

Equipotential bonding

For animals' safety and to prevent electrical faults, carry out an equipotential bonding of all metal parts such as automatic calf feeder, water conduits, sucking station and race-way out. At the rear of the calf feeder you will find the connecting screw of the equipotential bonding.

Lightning protection

As it is impossible to protect the installation separately against lightning stroke, it is to the owner to install an adequate lightning protection (e.g. a lightning protection system for the entire building). Insurance against lightning is recommended.

3.2 Installation of the automatic calf feeder

- It is recommended to install the automatic calf feeder in a dry place, if possible separated from the animal area, e.g. in the fodder storage or similar detached room.
- A fence of planks protects the automatic calf feeder against dirt and flies. In case you should have problems with flies, especially during the summer, you may protect the mixer jar by means of a fly cover. The steam coming out of the openings can escape through the grating.
- Frost is not damaging to the calf feeder. In order to guarantee a good functioning of the feeding process even in case of frost conditions you may equip the automatic calf feeder with a protection against frost (available as an accessory). The operator has to ensure a reliable water supply.
- The suction hoses can be easily guided through the wall.
- If possible place the milk storage tank next to the automatic feeder.

3.3 Mounting the sucking station

- Install the sucking station max. 65 cm above the ground of the stable.
The sucking station must be approx. 15 cm above the connection of the suction hose on the mixer.
- The suction hose must be dimensioned such, that the mixer jar can be tipped unhampered in forward direction. If possible the suction hoses must not exceed 2 m.
- Mount the suction bracket with splash board towards the bottom.

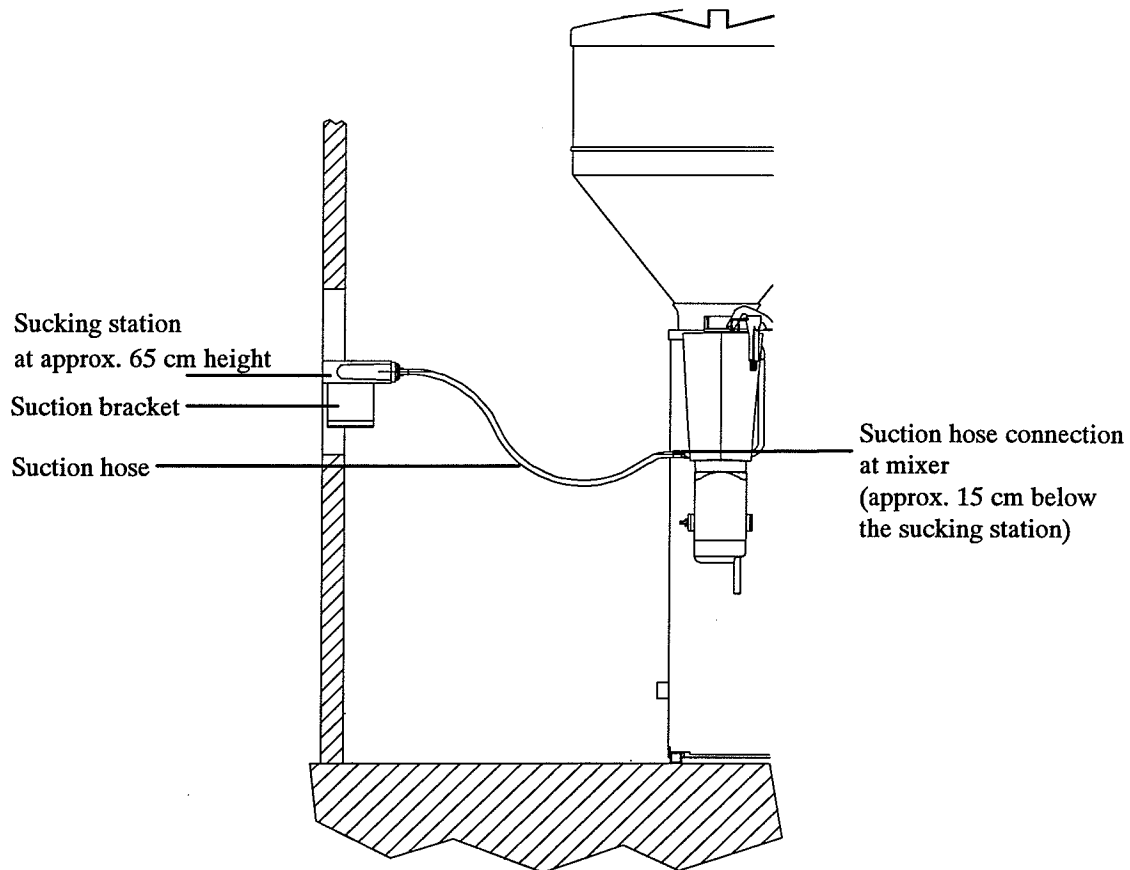

3.4 Mounting the race-way

The sucking station or the concentrate feeder must be preceded by an appropriate race-way, in order to protect a calf from being pushed aside by other calves.

- Install the race-way according to the installation manual.

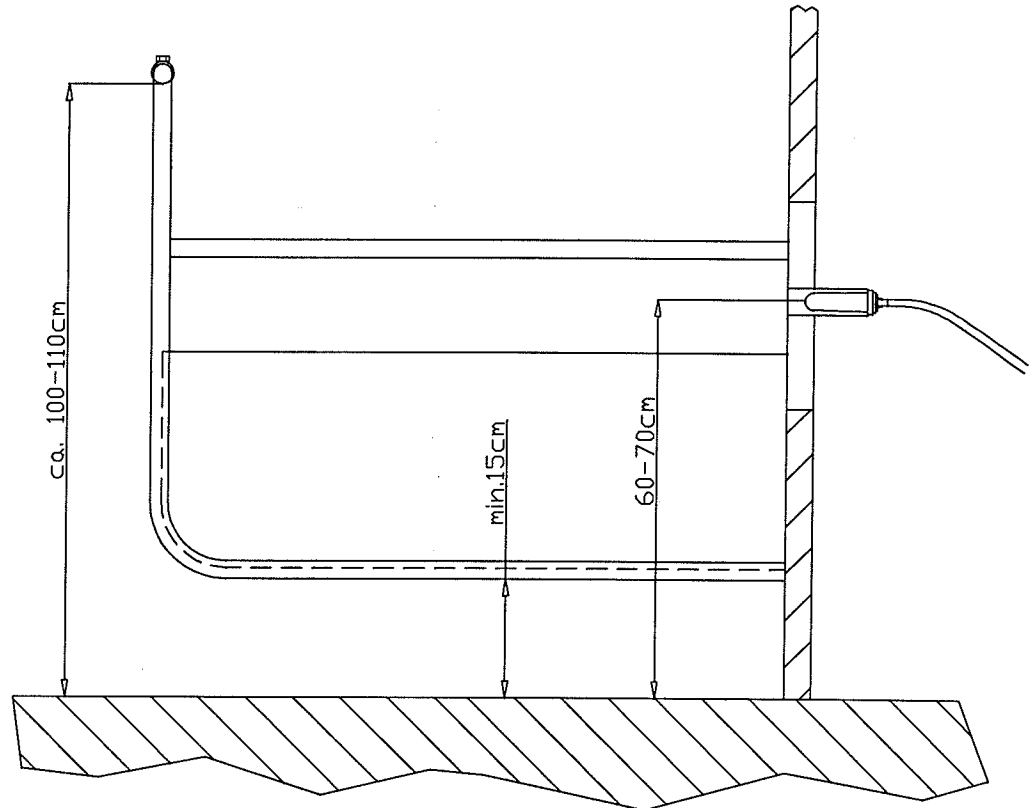

3.5 Connection micro-identification

- Connect the micro-identification according to the mounting instructions.



Install the cable for the micro-identification in such a way that it cannot be touched by the calves.

3.5.1 Identification „Mikro-Nedap“

- In case of „Mikro-Nedap“: Check wiring and program chip carefully.

You may check the identification range of the antenna by means of an antenna test (see chapter 5.11.3, page 55 ff, „Automatic registration of the Responder numbers and antenna test“). In case identification errors should occur, you may set the identification range by the Squelch-value. In case of connection of a concentrate feeder you have to set the Squelch-value in „Setup“. See chapter 5.7.1, page 36 ff, „Setup, activating the concentrate“.

3.5.2 Identification „Mikro-Tiris“

- In case of „Mikro-Tiris“: check wiring and program chip carefully.

You may check the identification range of the antenna by means of an antenna test (see chapter 5.11.3, page 55 ff, „Automatic registration of the Responder numbers and antenna test“). In case of double or alien identifications, you should install a screening by means of earthed metal sheet plates.

3.6 Mounting the top section of the milk powder hopper

- Place the top section of the milk powder hopper (part of the delivery) on the powder funnel of the automatic calf feeder and secure it with the appropriate screws and nuts (part of the delivery).



Only use the top section delivered. Do not raise the top section!

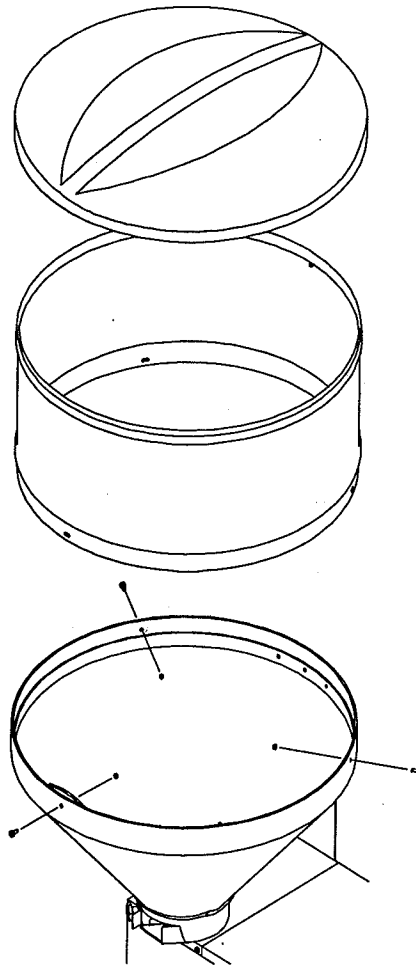

3.7 Water connection

- Connect the 1/2" water hose with a 3/4" hose coupling at the rear of the automatic calf feeder.

The water pressure supplied by customer has to be between 2,5 and 6 bar.



Note: To ensure a troublefree functioning of the automatic feeder, take care that the water pressure does not fall below 2,5 bar!

Take care that there is no pressure variation of the water pipe.

In case of water pipes with small cross section it may happen that, in the feeding mode or when water is taken out of the same pipe simultaneously, the water pressure will drop.

When the water pressure is below 2,5 bar you have to use a float tank (water tank).

Install additional water valve.

Up to August 31, 2000 the pressure reducer is factory-set to 2 bar. As of September 1, 2000 it will be factory-set to 1,5 bar.



Do not alter the setting of the pressure reducer!



In case the notes above should not be observed, there is no guarantee that the automatic feeder will run trouble-free!

4 Location of the concentrate feeder

- Connection of the concentrate feeder; refer to wiring diagram.
- Place the concentrate feeder in such a way, that the concentrate can be easily filled and maintenance is easy to carry out.
- The distance between Master-Station and Slave-Station should not exceed 6 m.

4.1 Mounting the concentrate feeder

- Mount the feeding bowl max. 55 cm above the box ground.

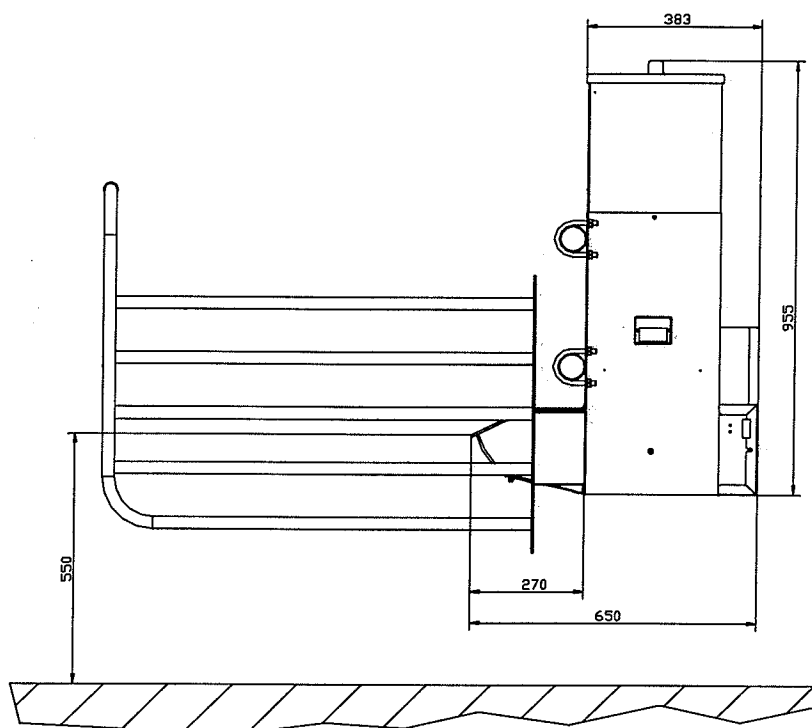

Diagrammatic view installation concentrate feeder:
Dimensions in mm

- Mounting of the race-way: refer to chapter „Location of the automatic calf feeder“
- Connect the antennas: refer to chapter „Location of the automatic calf feeder“
- A calf which wants to drink or is drinking has to be in the identification field (green LED on concentrate control must light). The distance between the transmitter and the identification must not exceed 20 cm, depending on the identification system used (ear tags or collar).



All cables must be installed in such way that they cannot be touched by the calves.

4.2 Filling of the concentrate feeder

The concentrate feeder can be filled with pellets, calf flakes and crushed or coarsely milled grains.



Fine-milled fodder or fodder with a high oats content may cause bridging. This can possibly lead to malfunctioning of the concentrate feeder.

Only fill with dry fodder!

4.3 Connecting the mains plug

Connect the mains plug of the concentrate feeder according to the electrical connection: refer to chapter 2, page 16, „*Technical Data*“

4.4 Checking and setting the dosing flap

Depending on the type of fodder and its composition, the dosed quantity will have a different volume. You may regulate the position of the dosing flap by means of the adjustable plate. You may increase (wide opening of dosing flap) or reduce (small opening of dosing flap) the feed quantity to be dispensed.

Checking the distribution of concentrate

- Check the transferred concentrate volume by means of a test Responder.
- If the volume in the feeding bowl should be too large or too small, change position of the adjustable plate with reed switch.
- Ensure that the dosing flap is running well.

Regulating the dosing flap

- Remove the cover next to the feeding bowl.

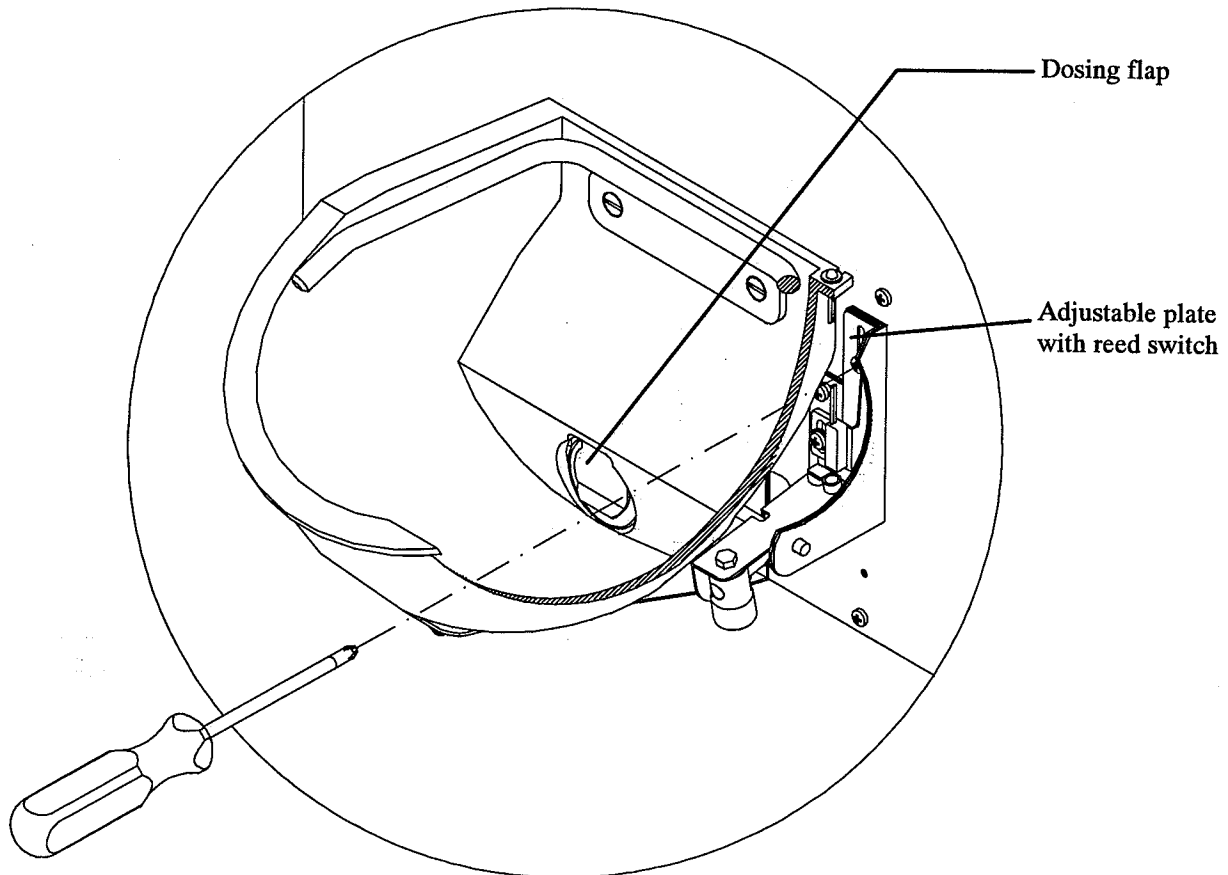

- Only loosen the screw on adjustable plate with reed switch (see above drawing).
- Move the adjustable plate upward or downward, in order to change the position of the dosing flap.
Upward: less fodder in the bowl. Take care that the signal empty will be displayed (LED must light).
Downward: more fodder in the bowl. After 5 - 6 seconds (= 5 rotations of the shaft) the signal empty has to disappear, otherwise the fault message „Idle shaft“ will be displayed.



The LED lights, when the dosing flap signals „empty“.

- Check the transferred concentrate volume by means of the test Transponder.
- After regulation of the dosing flap fasten the screw on the adjustable plate and secure the cover.

5 Installation of the automatic calf feeder

5.1 Connecting the mains plug of the automatic calf feeder



Warning: Before activating the heating, fill up the boiler in order to avoid damages and to guarantee a reliable functioning of the automatic calf feeder.

- Turn back both thermostats to zero and switch off the main switch (position „OFF“). On model „TAP1-SA2-27-F“ turn back the heating thermostat to zero.
- Connect the mains plug and switch on the calf feeder by turning the main switch to position „ON“. On model „TAP1-SA2-27-F“ activate the flip-switch situated on the right-hand side on the bottom of the operating and control unit.

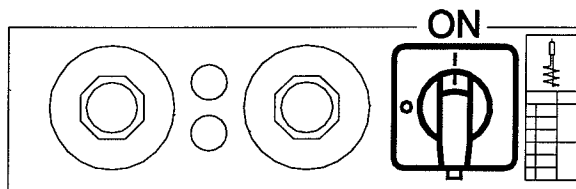

Once you switched on the automatic calf feeder, the display shortly shows the new program version. Then the Stand Alone carries out a test routine. The display shows the corresponding messages „Check....“

5.2 Filling the boiler with water

- Press the hand-operation button „Water“ until a heavy water jet flows into the mixer.

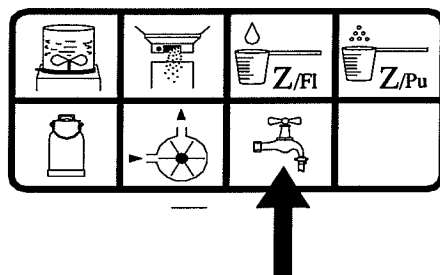

5.3 Filling the powder hopper with milk powder

- Only fill milk powder suitable for calf feeding. Do not put paper or other foreign matter into the powder hopper.



There is no warning in case the powder hopper should be empty! The automatic feeder continues working in the feeding mode without milk powder.

5.4 Operating and Control unit

5.4.1 Operating unit with processor and power supply unit

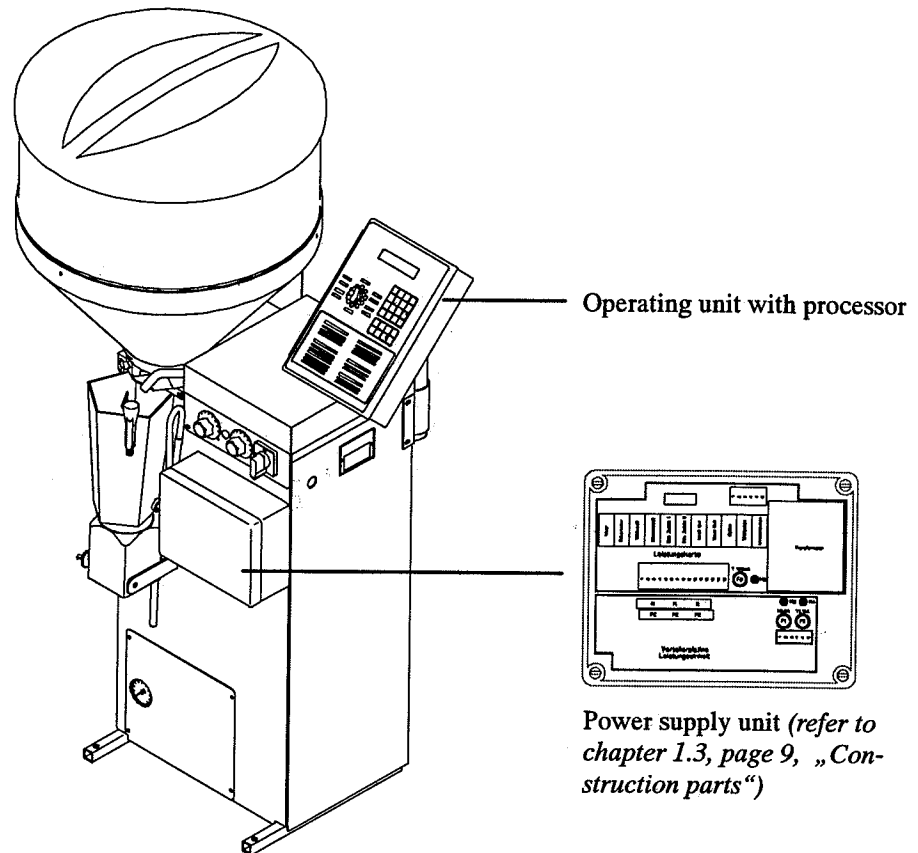

Operating unit with processor

On the operating unit with processor you can find the following controls:
Program switch, keyboard, hand-operation buttons and display.



If the connections on the lower part of the control are not used, they have to be concealed with covers.

Power supply unit

On the power supply unit you can find the transformer to power the processor control, the relays, as well as the sockets for external devices, the fuses and pilot lamps.

5.4.2 Operational controls

5.4.2.1 Program switch and switch menu

You can call up the switch menus (program switch position 1 - 9) by means of the program switch.

Switch menu

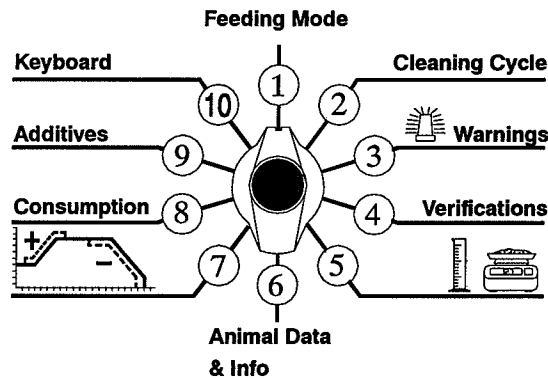

5.4.2.2 Keyboard and keyboard menu

Switch position 10 on the keyboard allows selection of the keyboard menus. In switch position 2 - 10 the keyboard is activated. When pressing the key which is active in this particular moment, you will hear a high-pitched sound.

Keyboard

←	→	⬆	Start Stop
1 Esc	2	3 ⬇	Enter
4	5	6	yes/no +/-
7	8	9	0 C

The keyboard menus are located on the lower part of the computer and framed.

Keyboard menu		
Operating Functions	Milk Feeding	Notes
Machine Data 1	Feeding plan 10	Vaccinations 30
Restricted / Ad libitum.... 2	Concentration plan 11	Treatments 31
Milk Functions 3	A/Po-Plan 12	
Accustoming Aid 4	A/Li-Plan 13	
Setup 5	Prescriptions (g/100 kg)... 14	
	Feeding Limits 15	
	Entitlement intervals..... 16	
Verification Functions	Concentrate	Delete Functions
Warning 20	Feeding Plan C1 40	Delay / Consumption 90
Printing 21	Feeding Plan C2 41	New installation 99
Total Consumption 22	Feeding Limits 42	
Interruption Check..... 23	Intervals..... 44	
Fault messages 24	Wean by C 45	
Scales 25	Connection Test 49	

Keyboard



When turning the program switch to 10, the display shows the following read-out:

keyboard
input:

The menu number required can be entered now. The number of the keyboard menu selected will appear on the display in the upper left area.

5# setup
concentrate

Keys with a double function:



The keys with the figures 1, 3 and 0 have two functions. The second function is always displayed on the right at the bottom of the white field. The figure is active when the memory is open (cursor flashes).

When the memory is closed (cursor does not flash) the second function is active.



„Esc“ brings you step by step back to the menu.



The key Arrow Down „v“ allows paging through the submenus.

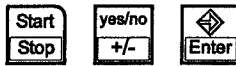

„C“ is the erase key and deletes e.g. warn calves.

Toggle keys:

When pressing the toggle keys the function will be reversed. The relevant function will always be shown on the display. „Start“ changes into „Stop“, „+“ changes into „-“, the memory is open or closed.

Horizontal arrow keys:

Arrow Right leads in case of closed memory (cursor does not flash) to the next read-out, Arrow Left leads to the preceding one to the left.

The small Arrow Right on the display indicates that on the right another read-out will follow.

**Vertical arrow keys:**

In case of closed memory you may call up the available menus by means of the vertical arrow keys after selection of the switch or keyboard menu.

These arrow keys are active when the display shows Arrow Up ^.



The Arrow Up next to the animal number indicates that with the arrow keys you can select the next higher or next lower animal number. The same goes for the selection of the animal groups A, B, C and D.

5.4.2.3 Hand-operation keys

In hand-operation mode the individual functions are switched on, independently of the control.

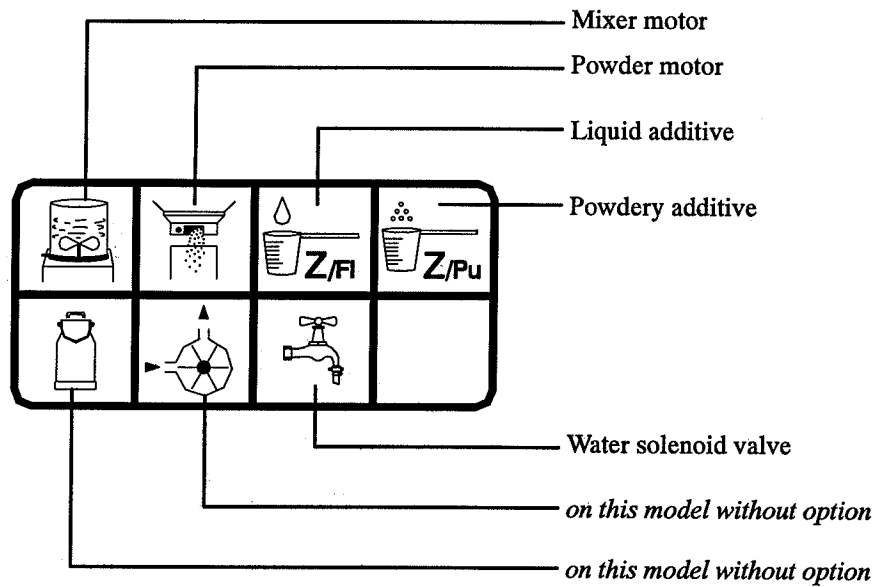

To spare its sealing, the mixer shall not be operated without liquid.

5.5.1 Exercises for the switch menus

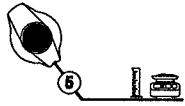

Turn the program switch to 5 = calibration. The first submenu is named „Water“.

```
calibration →
water      ^
```



Call submenu with Arrow Up and/or Arrow Down.

```
calibration →
water      ^
```



Change over to the next read-out by using Arrow Right.

```
water targ.:500ml →
measured:  ...ml
```

5.5.2 Exercise for the keyboard menus

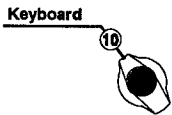

Turn the program switch to 10 = keyboard.



Enter 10 and confirm with ENTER.

```
10# feeding plan
group A ^ →
```



Go to first read-out, press ENTER, the cursor flashes.

```
10# A per.1 3 days
fr. 6,0 to 6,0 1 →
```

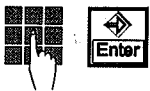

Enter a numeral representing the feeding period, confirm with ENTER.

```
10# A per.1 3 days
fr. 6,0 to 6,0 1 →
```

5.6 Basic settings during installation

5.6.1 Checking date/time

When installing the automatic calf feeder first of all date and time under System data in the keyboard menu have to be checked and if necessary, changed. Time goes on, even after the system has been switched off.

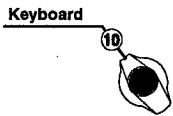

Turn program switch to 10 = keyboard.

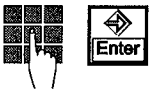

Enter 1 and confirm with ENTER.

```
1# date 21.07.98
time: 14:37:09
```



If necessary, press ENTER to adjust date and time.



Confirm again with ENTER.



After having changed the date, a daily calculation (*refer to chapter 7.6, page 95, „Daily calculation“*) will be immediately carried out at switch position „Feeding Mode“.

5.6.2 Carrying out new installation



Under the keyboard menu „New installation“ the function „all new“ must unconditionally be carried out at commissioning, to ensure that the memory does not contain false data. Animal data, which should be present, will be erased and preceding work data will be overwritten.

Animal data are for instance Responder numbers, group allocation, stabling dates, feeding days, consumed feed, etc..

Work data are data with which the system works, however, not established for specific animals (e.g. drinking plans, concentration plans). The standard values for work data are based on general experience and may be altered at any moment and adjusted to individual demands (*refer to chapter 6, page 68, „Altering operational data“*).

The examples of exercises for the entering routine are erased by the selection „New installation, all new“.

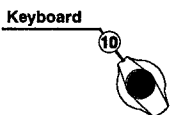

Turn program switch to 10 = keyboard.

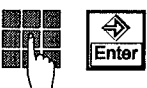

Enter 99 and confirm with ENTER.

```
99#newinstallation->
all new ? no
```



Select „yes“ and confirm with ENTER. All animal data will be erased and the work data will be overwritten by standard values.

```
99#newinstallation->
all new ? yes
```

A warning asks, whether the instructions in the user manual have been observed.

```
instruction manual
read ? no
```



Select „yes“ and confirm with ENTER.

```
instruction manual
read ? yes
```

After „New installation“ has been carried out, the message „finished“ appears in the second line of the display.

```
99#new installation
finished
```



This menu has a possibility to move to another read-out. If the automatic calf feeder is already operational, the standard values of the automatic calf feeder can (if desired) be recovered at all times. Manually changed values, e.g. of feeding plans will be erased and overwritten with standard values. Established animal numbers stay unaffected.



Move to the next read-out.

```
99#new installation
operat.data ? no
```



Select „yes“ and confirm with ENTER. All work data will be erased and overwritten with standard values.

```
99#new installation
operat.data ? yes
```

5.7 Setup

In Setup you may select the additional functions concerning concentrate, animal scales, heat exchanger and printing and enter the baud rate for PC and concentrate feeders. Interfaces can be tested and feeding boxes can be registered and cancelled. Moreover, in Setup you may set the draining time.

In case the Stand Alone has a mixer with automatic cleaning, you may activate this function in Setup too. In the submenu „Cleaning hose pipe“ the suction hose for calves can be rinsed with a water portion of 1/4 litre as of a certain age.

The settings in Setup influence the menu management. Not registered functions will not be indicated in the operator's management and cannot be used. If e.g. no concentrate has been activated, no concentrate menus will be displayed.

5.7.1 Activating the concentrate

Keyboard



Turn program switch to 10 = keyboard.



Enter 5 and confirm with ENTER. The menu „Concentrate“ appears on the display.

```
5# setup          →
concentrate ^
```



Use Arrow Right to go to the next read-out of the submenu Concentrate.

```
5# silo 1&2^    →
available no
```



Select the silo with Arrow Up or Arrow Down.

```
5# silo 1&2^    →
available no
```



Enter „yes“ behind the silo and confirm with ENTER.

```
5# silo 1&2     →
available yes
```



Register silo 1 and 2 if one Master with a possibly related Slave are connected. Register silo 3 and 4 if two Masters with possibly related Slaves are connected.



Go to the next read-out with Arrow Right.

```
5# silo 1^      →
C1
```



Select silo with Arrow Up or Arrow Down.

```
5# silo 1^      →
C1
```



Press ENTER to select type of concentrate.

```
5# silo 1       →
C1
```

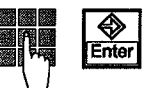

Enter type of concentrate (1 or 2), which is allocated to the related concentrate feeder and confirm with ENTER.

```
5# silo 1       →
C1
```



Go to the next read-out with Arrow Right and press ENTER.

```
5# dosing code  →
      1,0
```

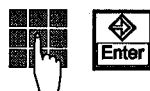

Enter code number and confirm with ENTER.

```
5# dosing code  →
      1,0
```



In case of micro-identification „Mikro-Nedap“ you may set the identification range of the antennas by the antenna-Squelch.



Move to the next read-out with Arrow Right and set the input and reading sensitivity of the antennas. The higher the Squelch value, the lower the identification range of the antennas. You may enter values between 0 and 200.

```
5# squelch antenna
concentrate 180  →
```



Confirm with ENTER.



In the following schedule you will find Squelch values and identification ranges for the different Responders. These Squelch values are based on experience and have already been factory-set.

Responder	Squelch (Standard values)	Identification range
X-Responder	0	max. 25 - 30 cm
Ear tag-Responder	0	max. 25 - 30 cm



The entered value is active, until you change it manually.

5.7.2 Setting the baud rate for PC and concentrate feeder



You have to set the same baud rate for the PC, as well as for the concentrate feeder. Concerning the data transmission speed you may choose between the following figures: 19200, 9600, 2400 or 1200. 19200 baud is the standard value. To avoid electrical interference from the vicinity, we would advise you to reduce the transmission speed.



Select menu „Set baudrate“ with Arrow Up or Arrow Down.

```
5# setup  →
set baud rate ^
```



Go to the next read-out with Arrow Right.

```
5# baud rate
19200 baud ^  yes
```



Select the baud rate with Arrow Up or Arrow Down, according to the transmission speed used.

```
5# baud rate
19200 baud ^  yes
```



Confirm with ENTER.

```
5# baud rate
19200 baud ^  yes
```

Standard value for baud rate: 19200 baud

Set the transmission speed at the Master station of the concentrate feeders by means of the DIP switches.

The value entered into the Stand Alone automatic calf feeder must correspond with the setting of the DIP switches at the concentrate feeder.

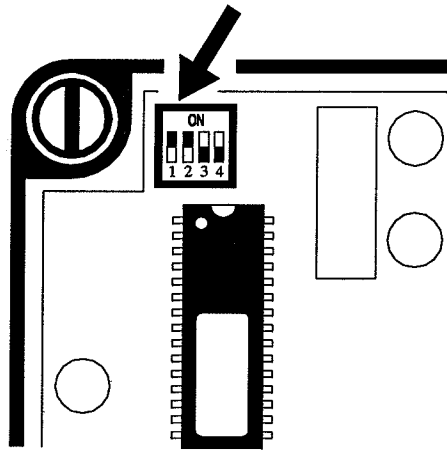

Master-Control (section)

Baud	Switch		ON OFF
	1	2	
19200	ON	ON	ON OFF
9600	ON	OFF	ON OFF
2400	OFF	ON	ON OFF
1200	OFF	OFF	ON OFF

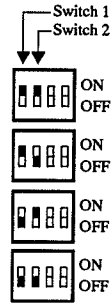

5.7.3 Selecting the printing function



Select menu „Printing“ with Arrow Up or Arrow Down.

```
5# setup
printing ^
```



Go to the next read-out with Arrow Right.

```
5# print list →
auto print no
```



Select „yes“, in case the verification list should be printed automatically at midnight. Confirm with ENTER.

```
5# print list →
auto print yes
```



Go to the next read-out with Arrow Right.

```
5# switch →
pr.channel 0^ no
```



Select printer channel for serial multiplexer (0-8) with Arrow Up or Arrow Down.

```
5# switch →
pr.channel 1^ yes
```

















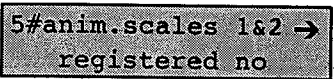



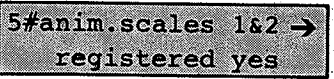

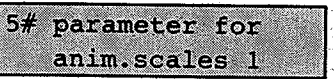



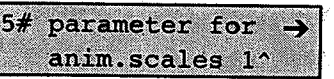

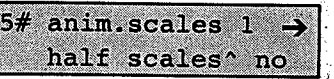
Enter „yes“ and confirm with ENTER.

```
5# switch →
pr.channel 1^ yes
```

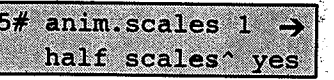

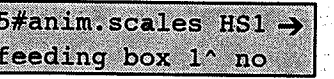
Printer channel 0 means that no serial multiplexer is connected. An entry is only required, in case the PC program „Kalb-Manager“ and the Stand Alone are connected to a printer by means of a serial multiplexer.

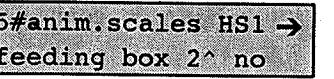
5.7.4 Selecting the animal scales

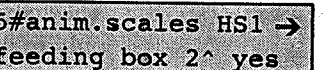
- | | | | |
|---|---|---|---|
|  |  | Select menu „Animal Scales“ by means of Arrow Up and Arrow Down. |  |
|  |  | Move to the next read-out with Arrow Right. |  |
|  | | Select „Animal Scales 1&2“ in case one full scales has been connected in feeding station 1 or two half-body scales have been connected in the feeding stations 1&2. Select „Animal Scales 3&4“ in case you connect an additional full scales or two additional half-body scales. | |
|  |  | Enter „yes“ and confirm with ENTER. |  |
| | | Enter „no“ in case the animal scales should be cancelled. | |
|  | | Move to the next read-out with Arrow Right. |  |
|  | | In this menu you can set the parameters of the animal scales selected. You may choose between full scales, half-body scales and assignment to the feeding stations. In case you connect a half-body scales, you may also set the weight factor to calculate the total weight of a calf and the tare value to calibrate the scales. The processor will convert the electronic signals of the weighing cell of the animal scales into an indication of weight. This conversion factor (= tare value) will be ascertained when putting a weight of approx. 50 kg on the animal scales. | |
|  |  | By means of Arrow Up and Arrow Down select the animal scales whose parameters have to be set. |  |
|  | | Move to the next read-out with Arrow Right. |  |
|  |  | Select the type of scales (full or half-body scales) by means of Arrow Up and Arrow Down. | |
|  |  | Enter „yes“, in case animal scales 1 should e.g. be a half-body scales. Confirm with ENTER. |  |
|  | | Move to the next read-out by pressing Arrow Right. |  |
|  |  | Select the feeding box where the animal scales has been located by means of Arrow Up and Arrow Down. |  |
|  |  | Enter „yes“, in case the half-body scales 1 (= HS1) has been installed in feeding box 2. Confirm with ENTER. |  |



The following read-out will only be displayed in case one or more half-body scales have been connected.



Move to the next read-out by means of Arrow Right.

```
5#anim.scales HS1 →
weight factor 178%
```



Press ENTER. Enter the weight factor needed to calculate the total weight of a calf. Standard value: 178 %.



Confirm with ENTER.



Move to the next read-out by means of Arrow Right. In this menu the automatic tare value will be ascertained and set.

```
5#HS1 tare value
1100 set ?      start
```



Press Start/Stop, in order to tare the half-body scales.

```
5#HS1 tare value
tare .....
```

After tare has been carried out, the display shows:

```
5# 50 kg put on
start
```



Press ENTER. Enter the weight value used for weighing. Standard value: 50 kg.



Confirm with Enter.



Put a weight on the scales (in case of 50 kg e. g. two sacks of milk powder). Press Start/Stop once again. The display shows:

```
5#HW1 tare value
scales.....
```

The tare value will automatically be set for the half-body scales connected. For example:

```
5#HW1 tare value
1100 set ?      start
```



Confirm the tare value indicated with ENTER.



In case the tare value should be checked once again, repeat the setting-routine for tare value.



Move to the next read-out by means of Arrow Right.

```
5#institute-program
no
```

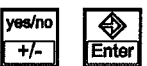

Enter „yes“, in case a PC for the evaluation program has been connected. Confirm with ENTER.

```
5#institute-program
yes
```



The special evaluation program for institutes (institute program) can be connected to box 2, only in case no scales have been activated for box 2.

5.7.5 Carrying out interface test



If it is impossible to create the connection with the concentrate stations, the printer or the PC or with possibly connected scales, an interface test should be carried out. This interface test will be carried out by Customer Service.

- Connect the test connector with the circuit card. *Refer to connecting diagram.*



Use Arrow Up or Arrow Down to select menu „Interface test“.

```
5# setup      →
interface test^
```



Go to the next read-out with Arrow Right.

```
interface
test 1^ chann. no
```



Use Arrow Up or Arrow Down to select channel 1-5.

```
interface
test 1^ chann. no
```

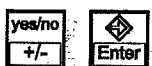

Enter „yes“ and confirm with ENTER.

```
interface
test 1^ chann. yes
```

5.7.6 Registering and cancelling feeding stations

In this menu you may register and cancel feeding stations. Moreover, here you may enter the draining time (time between release of the electrode at the final portion and closing of the two-group valve unit) for each station. You can enter the draining time only in case the automatic calf feeder has additionally been provided with a two-group valve unit.



Use Arrow Up or Arrow Down to select „Feeding boxes“.

```
5# setup      →
boxes^
```



Go to the next read-out with Arrow Right.

```
5# box no.   1^
available ? yes
```



Select feeding box (1 or 2).

```
5# box no.   1^
available ? yes
```



Cancel feeding box: enter „no“ and confirm with ENTER.

```
5# box no.   1^
available ? no
```

Register feeding box: enter „yes“ and confirm with ENTER.

```
5# box no.   1^
available ? yes
```

The feeding boxes 1 and 2 are regularly announced (yes).

Cancellation of a feeding box makes sense, if the automatic calf feeder has been provided with a quadruple priority control. If the quadruple priority control temporarily needs only 3 feeding boxes, cancellation of the fourth feeding box prevents the computer from asking for the values of the fourth feeding box.

If the feeding portion has to be transported over a long distance, it will be useful to extend the draining time. It ensures that the mixer bowl will entirely be emptied after consumption of the last portion.



Go to the next read-out with Arrow Right.

5# draining time
box 1^: 16 sec.



Select feeding box (1 or 2).

5# draining time
box 1^: 16 sec.



Confirm with ENTER.

5# draining time
box 1^: 16 sec.



Enter the feeding time in seconds and confirm with ENTER.

5# draining time
box 1^: 20 sec.

The standard value for the feeding time is 16 seconds. The entries range from 10 to 60 seconds.

5.7.7 Setting distribution pause

A distribution pause can be set. With the beginning of the drink preparation the shut-off valve or the two-group valve unit will close for the duration of the entered distribution pause. It is advisable to set a distribution pause only in case of not readily soluble milk powders, very high concentrations (> 200 g/l) and extreme drinking speeds (> 2 l/min).

To feed calves instantly after entering the feeding station, the first feeding portion will be distributed without distribution pause. After the last feeding portion for this calf the valve closes finally after the entered draining time.



With Arrow Up or Arrow Down select menu „distribution pause“.

5# setup →
distrib. pause ^



Go to the next read-out with Arrow Right and open the memory with ENTER.

5# distrib. pause
0 sec.



Enter the preferred distribution pause. Only enter values between 0 and 16 seconds.

5# distrib. pause
0 sec.



Confirm with ENTER.

5.7.8 Mixer: Activating the cleaning system (time-controlled)



Activate the cleaning system only, if the mixer has been provided with a rinse discharge. For functioning of the cleaning system, refer to chapter „Cleaning“.



With Arrow Up or Arrow Down select menu „Mixer“.

```
5# setup      →
  mixer ^
```



Go to the next read-out with Arrow Right.

```
5# mixer with
clean pipe ? no
```



Select „yes“, if the cleaning system has to be activated and confirm with ENTER.

```
5# mixer with
clean pipe ? yes
```

Enter „no“, if the mixer does not have an automatic rinse facility or if the cleaning system should not be activated. Confirm with ENTER.

```
5# mixer with
clean pipe ? no
```



Go to the next read-out with Arrow Right and open the memory with ENTER.

```
5# clean mixer 3
times automatically
```

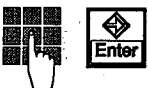

Enter the frequency of the automatic rinse cycles and confirm with ENTER. The entries range from 0 to 9.

```
5# clean mixer 3
times automatically
```

5.7.9 Selecting the retractable teat

In case the automatic calf feeder should be equipped with a retractable teat, you have to activate this function in Setup.



This menu will not be displayed in case of connection of a micro-identification.



Select the menu „Retractable teat“ with Arrow Up or Arrow Down.

```
5# Setup      →
  retractable teat ^
```



Move to the next read-out with Arrow Right.

```
5# retract. teat →
available ? no
```



Enter „yes“ in case the automatic calf feeder should be equipped with a retractable teat. Confirm with ENTER.

```
5# retract. teat →
available ? yes
```



Move to the next read-out with Arrow Right. Press ENTER.

```
5#retraction time →
teat : 50 ms
```

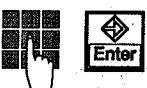

Enter the retraction time of the teat. Confirm with ENTER.

You may enter values between 50 and 500 ms. Standard values: 50 ms

5.7.10 Hose pipe cleaning

In this menu you may activate the hose pipe cleaning for calves of a certain group and from a certain age (weeks after first stabling).

Functioning: As soon as a calf has consumed the last portion of its allotment, 1/4 litre of water will be dosed into the mixer after the draining time. Calves usually stay a little bit longer in the feeding station sucking on the teat, effecting in this way the cleaning of the suction hose. As this only applies to older calves, this setting will be activated 2 weeks after stabling, at the earliest.



With Arrow Up or Arrow Down select menu „Hose Pipe Cleaning“.

```
5# setup      →
clean hose pipe ^
```



Go to the next read-out with Arrow Right.

```
5#clean hose pipe →
group A^ no
```



Select group.

```
5#clean hose pipe →
group B^ no
```



Enter „yes“ to select hose pipe cleaning for this group and confirm with ENTER.

```
5#clean hose pipe →
group B^ yes
```



Go to the next read-out with Arrow Right.

```
5# clean hose pipe
A from 5 weeks old
```



Enter age (weeks after first stabling) in weeks and confirm with ENTER.

```
5#clean hose pipe
A from 7 weeks old
```

The entries range from 2 to 9 weeks. Standard value: 5 weeks

5.7.11 Mixer: Activating the cleaning system (time-controlled)



Activate the cleaning system only, if the mixer has been provided with a rinse discharge. For functioning of the rinsing system, refer to chapter „Cleaning“.



With Arrow Up or Arrow Down select menu „Mixer“.

```
5# setup      →
mixer ^
```



Go to the next read-out with Arrow Right.

```
5# mixer with
clean pipe ? no
```

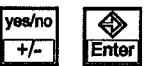

Select „yes“, if the cleaning system has to be activated and confirm with ENTER.

```
5# mixer with
clean pipe ? yes
```

Enter „no“, if the mixer does not have an automatic rinse facility or if the cleaning system should not be activated. Confirm with ENTER.

```
5# mixer with
clean pipe ? no
```



Go to the next read-out with Arrow Right and open the memory with ENTER.

```
5# clean mixer 3
times automatically
```

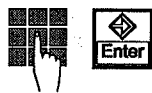
Enter the frequency of the automatic rinse cycles and confirm with ENTER. The entries range from 0 to 9.

5# clean mixer 3
times automatically

5.7.12 Selecting the retractable teat

In case the automatic calf feeder should be equipped with a retractable teat, you have to activate this function in the Setup.



This menu will not be displayed in case of connection of a micro-identification.



Select the menu „Retractable teat“ with Arrow Up or Arrow Down.

```
5# Setup →
retractable teat ^
```



Move to the next read-out with Arrow Right.

```
5# retract. teat →
available ? no
```



Enter „yes“ in case the automatic calf feeder should be equipped with a retractable teat. Confirm with ENTER.

```
5# retract. teat →
available ? yes
```



Move to the next read-out with Arrow Right. Press ENTER.

```
5#retraction time →
teat : 50 ms
```



Enter the retraction time of the teat. Confirm with ENTER.

You may enter values between 50 and 500 ms. Standard values: 50 ms

5.7.13 Hose pipe cleaning

In this menu you may activate the hose pipe cleaning for calves of a certain group and from a certain age (weeks after first stabling).

Functioning: As soon as a calf has consumed the last portion of its allotment, 1/4 litre of water will be dosed into the mixer after the draining time. Calves usually stay a little bit longer in the feeding station sucking on the teat, effecting in this way the cleaning of the suction hose. As it only applies to older calves, this setting will be activated 2 weeks after stabling, at the earliest.



With Arrow Up or Arrow Down select menu „Hose Pipe Cleaning“.

```
5# setup →
clean hose pipe ^
```



Go to the next read-out with Arrow Right.

```
5#clean hose pipe →
group A^ no
```



Select group.

```
5#clean hose pipe →
group B^ no
```

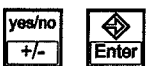

Enter „yes“ to select hose pipe cleaning for this group and confirm with ENTER.

```
5#clean hose pipe →
group B^ yes
```



Go to the next read-out with Arrow Right.

```
5# clean hose pipe
A from 5 weeks old
```

5.8 Connection test towards concentrate feeder

After appropriate connection of the connecting cable from the automatic calf feeder Stand Alone to the concentrate feeder you may carry out a connection test.

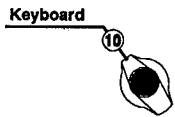

Turn program switch to 10 = keyboard.



Enter 49 and confirm with ENTER.

49#connection test→



Go to the next read-out with Arrow Right.

49# silo 1&2 test →
connection no



Select „yes“ and confirm with ENTER.

49# silo 1&2 test →
connection yes



Move to next read-out to reach silo 3 and 4.

49# silo 3&4 test →
connection no



Select „yes“ and confirm with ENTER.

49# silo 3&4 test →
connection yes

If the connection is correct, the message for e.g. silo 1 and 2 appears.

49# silo 1&2 test
connection ok



If the message „Connection error“ appears, test the connection cable towards the concentrate feeder and the power supply of the stations. Refer to wiring diagram.

49# silo 1&2 test
connection error !

If necessary, carry out an interface test, refer to chapter 5.7.5, Page 41, „Starting, Setup“.

5.9 Calibration

5.9.1 Calibrate water and MP

Calibration is defined as the input in the computer of the amount of water, MP and additive dispensed in a certain period of time. You may only enter the value of the actual transfer.

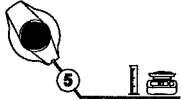

Turn the program switch to 5 = Calibration.

```
calibration  →
water        ^
```



Select submenu „Water“ or „MP“.

```
calibration  →
water        ^
```



Go to the next read-out with Arrow Right.

```
water targ.: 500 ml
measured:    ... ml
```



Hold an empty measuring vessel under the discharge.



Press the Start/Stop button.



Measure or weigh the collected quantity.



Press ENTER and enter the measured or weighed quantity.

```
water targ.: 500 ml
measured:    390 ml
```



Press again ENTER and confirm the entry.



Repeat the calibration procedure, in order to be sure.



Example: Calibration of water



After pressing the Start/Stop button 250 ml water was extracted.

```
water targ.: 500ml →
measured:    ... ml
```



Consequently, 250 must be entered and confirmed with ENTER.

```
water targ.: 500ml →
measured:    250ml
```



Example: Calibration of MP



After pressing the Start/Stop button, 85 g milk powder was extracted.

```
MP target:   100g →
measured:    ..g
```



Enter 85 and confirm with ENTER.

```
MP target: 100g →
measured : 85g
```



Repeat the calibration procedure, in order to be sure.



After pressing the Start/Stop button the entered figure disappears and in the second line points appear. If the set value is now extracted, calibration will be finished.

```
water targ.: 500ml →
measured: ...ml
```



After pressing Arrow Right the message appears with the time, at which the component involved was calibrated for the last time.

```
water last calib.
at 06.10.97
```



After pressing Arrow Right a message appears with the time required to transfer the indicated set volume.

```
water targ.: 500 ml
duration: 2,67 s
```

If the warning „Dosing time too long“ appears, the transferred volume or the measured or entered volume was too small. The set volume was not reached.

```
dosing time toolong
```



Repeat the calibration procedure, in order to be sure.

Standard values for calibration of milk, MP and water: 0

5.9.2 Calibrate additives

If an additive dispenser is connected, the additives must be calibrated, too.



Select submenu A/Po (Additive Powder) or A/Li (Additive Liquid).

```
calibration →
A/Po. ^
```



Go to the next read-out with Arrow Right.

```
calibration →
A/Po.R1 ^
```



With Arrow Up or Arrow Down select prescription 1-5 (A/Po.R 1-5) or plan (A/Po.PL).

```
calibration →
A/Po.R1 ^
```



Go to the next read-out with Arrow Right.

```
A/Po.R1 targ:10,0g →
measured: . . .g
```



Hold measuring vessel under discharge.



Press Start/Stop button.



Measure or weigh the collected quantity.



Press ENTER. Enter the measured or weighed quantity.

A/Po.R1 targ:10,0g→
measured: 8,0g



Confirm with ENTER.



Weigh the powdery additives with precision scales (e.g. electronic scales). Weighing precision must be 0.1 g. Hold the measuring vessel under the discharge. Press the Start/Stop button. Weigh the extracted quantity and enter the measured or weighed value.



If precision scales are not at your disposal, the calibration procedure has to be repeated several times, in order to get a larger volume of the additive. Then, divide the measured volume by the number of calibrations and enter the value.



Measure liquid additives with a cylinder.

Each additive recipe or additive plan must be calibrated.



Repeat the calibration procedure, in order to be sure.

Standard value for calibration of additives: 0
--

5.9.3 Calibration of concentrate

Calibrate separately for each concentrate station.

- Clean feeding bowl.
- Press the calibration key at the concentrate station involved and wait until dosing automatically switches off.

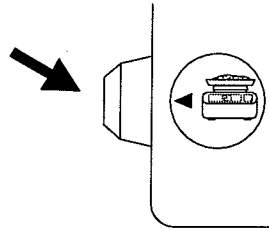

- Remove the entire quantity from the feeding bowl and weigh it.



The quantity to be calibrated will only be extracted, if no calf is within identification of the station. The slide switch in the Master must be on „Restricted“. If the slide switch is on „ad lib“, switch over to „Restricted“ and press RESET, until both red alarm LED's light up, then release RESET.

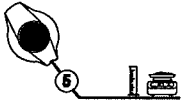

Enter the calibration values in Stand Alone.
Turn the program switch to 5 = Calibration.



Select submenu „concentrate“. The submenus only appear, if concentrate has been activated in Setup.

```
calibration  →
concentrate  ^
```



Go to the next read-out with Arrow Right.

```
calibration  →
concentrate silo:1^
```



Select concentrate Silo (1-4) with Arrow Up or Arrow Down.

```
calibration  →
concentrate silo:1^
```



Confirm with ENTER.



Go to the next read-out with Arrow Right, example for Silo 1:

```
silo 1 dosing  →
quantity:      0 g
```



Press ENTER. Enter the quantity, acquired and weighed during Calibration.



Confirm with ENTER.

Similarly carry out the calibration routine for following registered silos.

Standard value for calibration of concentrate: 0

5.10 Setting the heating



Only switch on the heating, if the heat exchanger is filled up with water and the water has been calibrated!

Minimum operating temperature (available as an option on model „TAP1-SA2-27-F“) and heating:

The minimum operating temperature prevents too cold milk or water from being dispensed. If the temperature in the boiler falls below the minimum temperature of the water in the heat exchanger, the preparation of the feeding will be interrupted until the minimum temperature has been reached.

If the minimum operating temperature is not reached, the display shows:

check temperature

Factory settings:

The minimum operating temperature has already been factory-set between 38°C and 39°C degrees. The minimum operating temperature should at all times be set 3°C under the heating temperature, in order to avoid overlaps in the control range.

The heating temperature is factory-set between 42°C and 43°C degrees.

5.10.1 Setting the thermostats



The thermostat for minimum operating temperature is available as an option on model „TAP1-SA2-27-F“.

- Release locking screws of both thermostat turning knobs.
- Turn the thermostat for minimum operating temperature (green) so far clockwise, until both marks coincide.

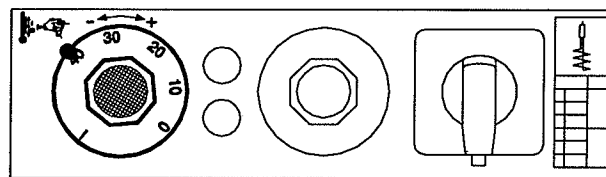

- Turn the thermostat for boiler heating (red) so far clockwise, until both red marks coincide.

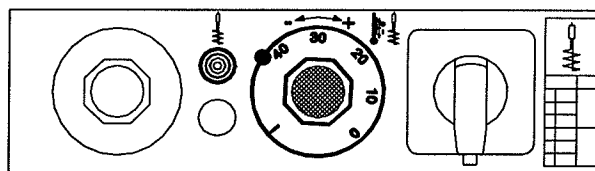

The marks facilitate the setting of the temperature.
However, a regular personal check is necessary.

5.10.2 Recommendations for temperature settings

In case of cheaper milk powders with higher fat melting point the delivered temperature must be set between 42°C and 43°C. In case of cold-soluble milk powders a temperature of approx. 38°C will be sufficient.



The temperature must be set carefully. If the heating temperature is set at a lower level the minimum operating temperature has to be lowered accordingly.
Too low temperatures may cause indigestion whereas too high temperatures over a long period may lead to inflammation of the mucosa in the abomasum. Flatulence may indicate that the drinking temperature is too high.

5.10.3 Measuring the temperature



The heating regulation suits to the portion size and the drinking speed of the calves. To measure the temperature do not extract more than 0.5 l. For further measurements, wait until the boiler has restored the temperature. The heat transmission time depends on the intake and discharge temperatures of the liquid and may vary between 10 and 25 seconds.

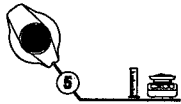

Turn the program switch to 5 = Calibration.

```
calibration →
water      ^
```

- Wait until the orange pilot lamp of the boiler water heating has extinguished.



Select submenu „Water“ in order to extract 1/2 litre of water.

```
calibration →
water      ^
```



Go to the next read-out with Arrow Right.

```
water targ.: 500ml
measured:    ..ml
```



Hold measuring vessel under the discharge.
Press the Start/Stop button.



Measure the temperature immediately with a precision thermometer.



Wait for the heat transfer time (approx. 30 seconds), prior to handing out the next portion.
After careful measuring, correct the temperature, if necessary, until the desired temperature has been reached. When temperature has been adjusted correctly, the locking screws can be fastened. Wait in case of following measurements until the orange pilot lamp for the heating has extinguished.

5.11 Animal identification and Responder number input

5.11.1 Animal identification

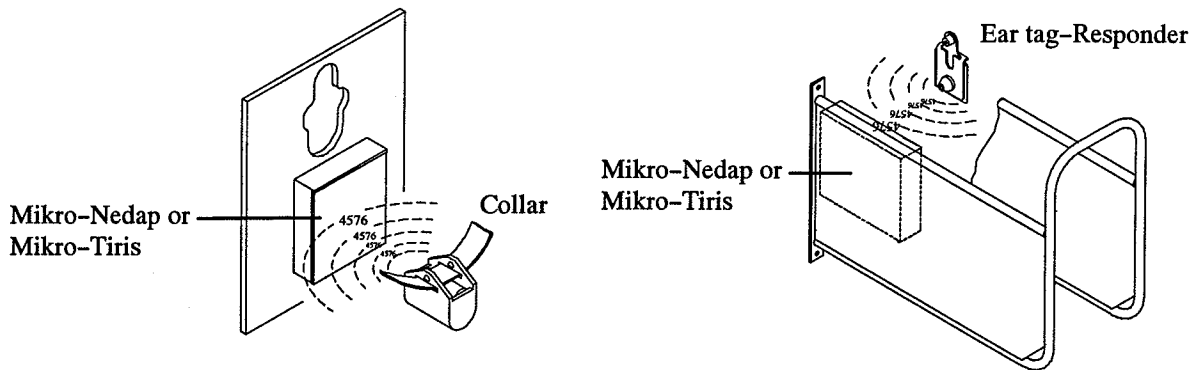

Each animal has to wear a collar with a Responder or an ear tag Responder in order to be identified. The Responder has a 4-position number imprinted on it. This number, designated as a Responder number, is transmitted via transmitter signals from the Responder to the antenna in the feeding station.

As the Responder number is not suitable for rapid identification of individual animals, each animal has on its collar or in its ear additionally a large animal number, you can easily remember and read even from a great distance.

The system accepts animal numbers from 1 to 999. However, only 99 animals can be managed or stored. This means that only 99 out of 999 possible animal numbers can be made available for animal identification with Responder numbers.

The animal numbers can be splitted up into three categories with the following features:

Before entering the Responder numbers, all animal numbers are marked with a „-“, following the animal number.

Once you entered Responder numbers, the animal numbers become available for animal marking. Available animal numbers are marked with an „a“, following the number.

Once you registered the animals, these numbers are not available anymore until you cancel them. The animal numbers that have been registered are marked with a large group letter, following the animal number (A, B, C, D).

12-	Animal number 12 has not been allocated to a Responder number.
12a	Animal number 12 has been allocated to a Responder number. Animal number 12 is available.
12A	Animal number 12 has been registered in group A.

5.11.2 Check connection between micro-identification and Stand Alone

In case the micro-identification has been connected correctly, in position „Feeding mode“ the symbol ≠ will be displayed on the second line of the read-out, as soon as a calf has been identified. No symbol will be displayed when no calf has been identified.

5.11.3 Automatic reading of the Responder number and Antenna test

Responder numbers can be read automatically or entered on the keyboard. Automatic reading of Responder numbers facilitates commissioning of the automatic calf feeder. It requires less time than manual entry. False entries can be avoided.



Turn the program switch to 6 = Animal data and Info.

```
animal data &Info →
weight, days fed ^
```



Select submenu „Responder input“.

```
animal data &Info →
responder input ^
```



Go to the next read-out with Arrow Right.

```
animal No:      1-^
resp. No:      0
```



Select animal number.



Hold the Responder of the selected collar within reach of the antenna.



Press the Start/Stop button. A beep is emitted when the Responder is read. The cursor blinks on zero when the number has not been read.

```
animal No:      1a^
resp. No:      1234
```



Press ENTER to confirm the number.



Go to the next read-out with Arrow Right to start the antenna test. Thanks to the antenna test, overlappings in the identification range can be detected.

```
antenna test start→
```



Press the Start/Stop button. A beep is emitted, when the Responder is read. The Responder number read appears in the text area at the right next to the antenna symbol.

```
≠ 383 ≠ 384
```



Two different Responder at two antennas can be read simultaneously. If, for instance, at antenna 1 a Responder is read, which actually should be allocated to antenna 2, we talk about faulty identification caused by an overlap of reach. Faulty identification also occurs, when calves standing beside the feeding box are identified. In case of micro-identification „Mikro-Nedap“ you may set the identification range of the antenna by the antenna-Squelch

value. In case of micro-identification „Mikro-Tiris“, install a screening of the antennas by means of earthed metal sheet plates. If necessary, close off the area beside the feeding station.



Move to the next read-out. Set the input or reading sensitivity of the antennas. The higher the entered value, the lower the antenna range. You may enter values between 0 and 200.

```
squelch antenna
feeding 180 →
```



Confirm with ENTER.



In the following table you will find Squelch values and identification ranges for the different Responders. These Squelch values are based on experience and have already been factory-set.

Responder	Squelch (Standard values)	Identification range
X-Responder	0	max. 25 - 30 cm
Ear tag-Responder	0	max. 25 - 30 cm



The entered value will be active, until you change it manually.

5.11.4 Manual input of Responder numbers



Press ENTER. Subsequently enter the animal number desired and the related Responder number.

```
animal No: 1a^
resp. No: 1234
```



Confirm with ENTER.



Select the next animal number by means of Arrow Up or Arrow Down.

```
animal No: 2a^
resp. No: 1235
```



Confirm with ENTER.



After Responder input has been completed, press ESCAPE to return to the menu.

5.12 Registration of animals

- At registration the animals are allocated to several feeding groups according to their animal numbers. Animal registration may take place individually, per group or automatically. The animals can be registered in four different groups (A, B, C, D). In this way it is possible to feed them according to the allocation per group. Example:
- Group A for heifers (less increase),
 - Group B for bull calves (more increase),
 - Group C for white veal calves,
 - Group D for other calves.

The division per group is only related to the rearing of the animals by the appropriate feeding plans. All four groups can be served at any drinking box of the automatic calf feeder, i.e., the division per group does not depend on the bays, in which the calves are.

Only valid for Combi-types: If animals receive either milk or MP and water, these animals have to be registered in different groups.

5.12.1 Registration of individual animals

If the animal stock (gender, age, weight) is not homogenous, the animals must be registered individually in their specific group.



Turn the program switch to 6 = Animal data and Info.

animal data & Info →
weight, days fed ^



Select submenu „Register“.

animal data & Info →
register ^



Go to the next read-out with Arrow Right. Information about available animal numbers appears.

8 anim. numbers →
are available



Go to the next read-out with Arrow Right.

1a^ register in A^



Select animal number.

12a^register in A^



Confirm with ENTER.

12a^register in A^

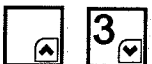

Select group (A, B, C, D).

12a^register in B^



Confirm with ENTER.

If in Setup no scales have been activated, the cursor jumps automatically to the read-out:

12B^ weight 60 kg
LWG +350 g/day

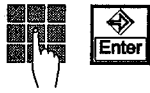

Enter the weight of the calf and confirm with ENTER.

12B^ weight 55 kg
LWG +350 g/day



Entering of the weight is mandatory, if during the feeding period weight-dependent additives according to prescription must be fed. In this way the animals automatically get their weight-related quantity of the additive.

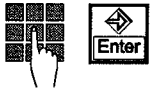

Subsequently enter the estimated real daily increase.

12B^ weight 55 kg
LWG +320 g/day



Confirm again with ENTER. In this way the weight will be daily recorded.

Adaptation of the daily increase:

As little (light-weight) calves increase by a lesser rate than large (heavy) ones, the daily increase will be automatically adjusted by 2 %. In this way the increase will be adapted to the weight development of the calf.

False manual entry:

A false manual entry for the group selection can, after a terminated registration, be rectified at a later stage in submenu „Change Registration“.

A false manual entry at entering the weight or the daily increase can be rectified in submenu „Weight and feeding days“.

Date setting:

At the registration the actual date will automatically be accepted as stabling date. This date cannot be changed.

By being registered all calves start the feeding plans on the first day.
For instance on the first day of the feeding plan.

At the end of the registration the following read-out appears:

1A^ is registered



Call the next available animal number.

13a^register in B^



After pressing ENTER the previously selected group, the last weight entry and the daily increase will automatically be suggested and can be confirmed with ENTER or entered manually as well.

13B^ weight 55 kg
LWG +320 g/day



Press ESCAPE to return to the menu after registration of the last animal.

5.12.2 Registration of groups

With a homogenous animal stock (gender, age, weight) several animals can be simultaneously registered for a group.



Turn the program switch to 6 = Animal data and Info.

```
animal data & Info →
weight, days fed ^
```



Select submenu „Register groups“.

```
animal data & Info →
register groups ^
```

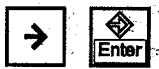

Go to the next read-out with Arrow Right and press ENTER.

```
anim. 1 to 999 →
register in A ^
```



Enter the first desired animal number and confirm with ENTER.



Enter the last desired animal number and confirm with ENTER.



Select the group.

```
anim. 1 to 999 →
register in A ^
```



Confirm with ENTER.

```
anim. 1 to 25 →
register in B ^
```

The following read-out will appear:

```
B weight 60 kg →
LWG 350 g/day
```



Press ENTER. Enter a representing animal weight and the estimated daily increase.



Confirm with ENTER. Information about the number of registered animals appears.

```
25 anim. have been
registered
```

If one or more animal numbers have not been cancelled, and consequently are not available, the display shows e.g.:

```
fr. No. 1 to 25
not all available
```



Go to the next read-out with Arrow Right.

```
not available anim.
cancel regist.? no
```



Confirm with „no“, if only available numbers must be registered.

```
not available anim.
cancel regist.? no
```



Select „yes“, if non-available numbers have to be cancelled.

```
not available anim.
cancel regist.? yes
```

The display shows the number of registered animals.

```
23 anim. have been
registered
```

5.12.3 Automatic registration

Automatic Registration is a shortened operator routine, which simplifies the registration of animals. Contrary to the registration of individual animals or registration for groups, there is no need to enter animal numbers and animal-specific data (such as weight, estimated daily increase). If in the feeding box an available number is identified, it will automatically be registered for a pre-selected group.



Animal Data & Info

Turn the program switch to 6 = Animal Data and Info.

```
animal data & Info→
weight, days fed ^
```



Select submenu „Automatic Register“.

```
animal data & Info→
automatic register^
```



Go to the next read-out with Arrow Right.

```
automatic →
register no
```



Select „yes“ and confirm with ENTER.

```
automatic →
register yes
```



Go to the next read-out with Arrow Right and press ENTER.

```
gr. A^ wei. + 60 kg
LWG +350 g/day
```



Select group.



Confirm with ENTER.

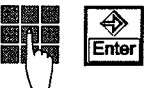

Enter a realistic stabling weight and press ENTER.



Enter the estimated daily increase and confirm with ENTER.



The automatic registration remains active, until „no“ will be entered.

Each identified and available number will later be registered for the selected group with the entered weight and the daily increase.

If the function „Automatic Registration“ remains active, calves to be cancelled must,

- either be removed from the bay,
- or the Transponder must be taken off,

otherwise they would automatically register themselves anew.

5.13 Entering correction days

With correction days each animal can be shifted to each point of the relevant curve (e.g. feeding plan, concentration plan, also refer to chapter 6 ff, page 68 ff, „Altering operational data“).

Positive numbers (with +): By entering positive numbers, calves are placed in an older-age bracket and on the curve shifted to the right.

Negative numbers (with -): By entering negative numbers animals are placed in a younger-age bracket and on the curve shifted to the left.



Animal Data & Info

Turn the program switch to 6 = Animal data and Info.

animal data & Info →
weight, days fed ^



Go to the third read-out with Arrow Right.

2A^corr. + 0 days
expires in 77days



Select animal number.



Confirm with ENTER.



Enter the number of correction days and confirm with ENTER.



As the animals at registration on the first day start the curve, negative numbers will not be accepted at stabling, because no animal can be fed prior to the start of the curve. The calves cannot be made younger, immediately after stabling.

If at feeding with concentrate automatic drinking was activated and the calf exceeded the start value, the first line shows e.g. „weang.+ 5 days“ (weang. = weaning days) instead of e.g. „corr. + 0 days“. In this example the calf will be shifted to the right of the feeding plan by 5 days.

5.14 Entering deviations

With the program switch in this position, drinking quantities, concentration, concentrate or additive quantity can be changed per animal.



The submenus for the additives only appear, if at least one animal gets an additive.

5.14.1 Deviations of drinking portions

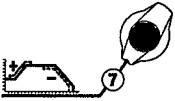

Turn the program switch to 7 = Deviations.



Select submenu „Feeding“.

```
+/- deviation  →
feeding        ^
```



Go to the next read-out. The first line contains information on the actual daily drinking portion. On the second line the feeding portion (departing from the drinking plan) can be increased or decreased for a certain number of days.

```
12C^ dr.:    7,0 l
for 0 days +0,0 l
```



Press ENTER. Enter the animal number.

```
14C^ dr.:    7,0 l
for 0 days +0,0 l
```



Confirm with ENTER. E.g. the following image appears:

```
14C^ dr. transfer
1,5 l delete no
```

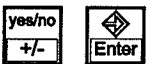

Select „yes“, if the rest should be deleted. Confirm with ENTER.

```
14C^ dr. transfer
1,5 l delete yes
```



Select „no“, if the rest should remain. Confirm with ENTER.

```
14C^ dr. transfer
1,5 l delete no
```



Go to the next read-out.

```
14C^ dr.:    7,0 l
for 0 days +0,0 l
```



Press ENTER. Enter the daily number for the duration of the addition/reduction.

```
14C^ dr.:    7,0 l
for 3 days +0,0 l
```



Confirm with ENTER.

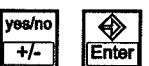

Make the selection with the plus/minus key „+“ for addition and „-“ for reduction. Confirm with ENTER.

```
14C^ dr.:    7,0 l
for 3 days -0,0 l
```





Enter the value for the addition or reduction and confirm with ENTER.

```
14C^ dr.:    7,0 l
for 3 days -2,0 l
```



At the end of the day the relevant animal appears as a periodic animal and reappears on the plan.



5.14.2 Deviations of concentration

- 



Select submenu „Concentration“.

+/- deviation →
concentration ^
- 



Go to the next read-out. The first line contains information on the actual concentration. On the second line the concentration (departing from the concentration plan) can be increased or decreased for a certain number of days.

14C^ conc: 120 g/l
for 0 days +0 g/l
- 



Press ENTER. Enter the daily figure for the duration of the Addition/Reduction.

14C^ conc: 120 g/l
for 3 days +0 g/l
- 

Confirm with ENTER.

14C^ conc: 120 g/l
for 3 days +0 g/l
- 

Select with the plus/minus key „+“ for Addition and „-“ for Reduction. Confirm with ENTER.



14C^ conc: 120 g/l
for 3 days +0 g/l
- 

Select the quantity of addition or reduction and confirm with ENTER.

14C^ conc: 120 g/l
for 3 days +10 g/l
- 

After elapse of the days, on which the animal gets increased or decreased concentration, the relevant animal appears as an expired animal and reappears on the concentration plan.



5.14.3 Deviations of concentrate

- 



Select „Concentrate“.

+/- deviation →
concentrate ^
- 



Go to the next read-out. The first line contains information on the actual quantity of concentrate type 1. In the second line the quantity of concentrate (departing from the concentrate plan) can be increased or decreased for a certain number of days.

14C^ C1 0,4 kg
for 0 days +0,0 kg
- 



Press ENTER. Enter the daily figure for the duration of the Addition/Reduction.

14C^ C1 0,4 kg
for 5 days +0,0 kg
- 

Confirm with ENTER.

14C^ C1 0,4 kg
for 5 days +0,0 kg
- 

Select with the plus/minus key „+“ for Addition and „-“ for Reduction. Confirm with ENTER.

14C^ C1 0,4 kg
for 5 days +0,0 kg
- 

Select the quantity of addition or reduction and confirm with ENTER.

14C^ C1 0,4 kg
for 5 days +0,2 kg



After elapse of the days, on which the animal gets an increased or decreased quantity of concentrate, the relevant animal appears as an expired animal and reappears on the feeding plan.



Go to the next read-out. For concentrate type 2 act as with concentrate type 1.

```
12C^  C2    0,7 kg
for  0 days +0,0 kg
```

5.14.4 Deviations of powdery additives

This submenu only appears, if an additional powdery additive has been activated.



Select submenu „Additive powder“.

```
+/- deviation  →
additive powder ^
```



Go to the next read-out. The first line contains information, on whether a recipe and which one has been activated or whether a Powdery Additive Plan has been activated (R = Recipe = Prescription with no. 1-5, Pl = Plan) and the actual daily quantity. In the second line the quantity of additive can be increased (enter +) or decreased (enter -) for a certain number of days.

```
14C^  PoR1 20g/100kg
for  0 dy +0g/100kg
```



Press ENTER. Enter the daily figure for the duration of the Addition/Reduction.

```
14C^  PoR1 20g/100kg
for  4 dy +0g/100kg
```



Confirm with ENTER.

```
14C^  PoR1 20g/100kg
for  4 dy +0g/100kg
```



Select with the plus/minus key „+“ for Addition and „-“ for Reduction. Confirm with ENTER.

```
14C^  PoR1 20g/100kg
for  4 dy -0g/100kg
```



Select the quantity of addition or reduction and confirm with ENTER.

```
14C^  PoR1 20g/100kg
for  4 dy -8g/100kg
```



After elapse of the days, on which the calf gets an increased or decreased quantity, the relevant animal appears as an expired animal. From then on the animal gets no longer addition/reduction.

5.14.5 Deviations of liquid additives

This submenu only appears, if liquid additive has been activated.



Select submenu „Additive Liquid“.

```
+/- deviation →
additive liquid ^
```



Go to the next read-out. The first line contains information, on whether a recipe and which one has been activated or whether a Liquid Additive Plan has been activated (R = Recipe with no. 6-9, Pl = Plan) and the actual daily quantity. In the second line the quantity of additive can be increased (enter +) or decreased (enter -) for a certain number of days.

```
14C^ Li.R6 20g/100kg
for 0 dy +0g/100kg
```



Press ENTER. Enter the daily figure for the duration of the Addition/Reduction.

```
12C^ Li.R6 20g/100kg
for 2 dy +0g/100kg
```



Confirm with ENTER.

```
12C^ Li.R6 20g/100kg
for 2 dy +0g/100kg
```



Select with the plus/minus key „+“ for Addition and „-“ for Reduction. Confirm with ENTER.

```
12C^ Li.R6 20g/100kg
for 2 dy +0g/100kg
```



Select the quantity of addition or reduction and confirm with ENTER.

```
12C^ Li.R6 20g/100kg
for 2 dy +5g/100kg
```



After elapse of the days, on which the calf gets an increased or decreased quantity, the relevant animal appears as an expired animal. From then on the animal gets no longer addition/reduction.

5.15 Accustoming aid

A feeding box can be temporarily blocked, to allow an undisturbed accustoming aid.

Turn the program switch to 10 = keyboard.

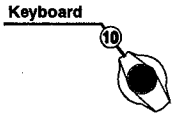

Enter 4 and confirm with ENTER.

```
4# accustom. aid →
   feeding box ^
```



Go to the next read-out.

```
4# box 1^ accustom.
   for 60 min ? no
```



Select box number 1 or 2.

```
4# box 2^ accustom.
   for 60 min ? no
```



Press ENTER. Enter the duration of accustoming aid (up to 180 minutes = 3 hours). During this time the identification of the other station is inactive.

```
4# box 2^ accustom.
   for 90 min ? no
```



Confirm with ENTER.

```
4# box 2^ accustom.
   for 90 min ? no
```



Select „yes“ and confirm with ENTER.

```
4# box 2^ accustom.
   for 90 min ? yes
```



Go to the next read-out.

```
4# warn calves ^ →
   priority ? no
```



Select „Warning calves“, „Box 1“ or „Box 2“. There is always only one box or the warn calves respectively, which will have priority. It is e.g. impossible to feed warn animals and box 1 with priority.

```
4# warn calves ^ →
   priority ? yes
```



Select „yes“ to let warn animals drinking with priority and confirm with ENTER.

```
4# box 1 ^ →
   priority ? no
```



Go to the next read-out.

```
4# box 2 ^ →
   priority ? no
```



Select box 1 or 2.

```
4# box 2 ^ →
   priority ? yes
```



Select „yes“ and confirm with ENTER.



After entering the time required for the accustoming aid in this menu, the priority of the warning animals or a feeding box at issuing the drinking, goes beyond the time of the accu-

stoming aid. Warning animals or feeding box have priority until the setting in this menu is restored to „no“. A further possibility is to carry out a „New installation, all new“. Subsequently, animals or boxes respectively have no longer feeding priority.

6 Altering Operational Data

Operational data are data concerning the distribution of drinking and concentrate, such as e.g. feeding plans, warning levels etc. During installation (according to „New Installation“) the operational data are processed as standard values. These standard values are based on experience and may be altered and animal-specifically adapted at any time.

6.1 Feeding plans

6.1.1 Age-dependent drinking

Periods of a feeding plan
Förster-Technik

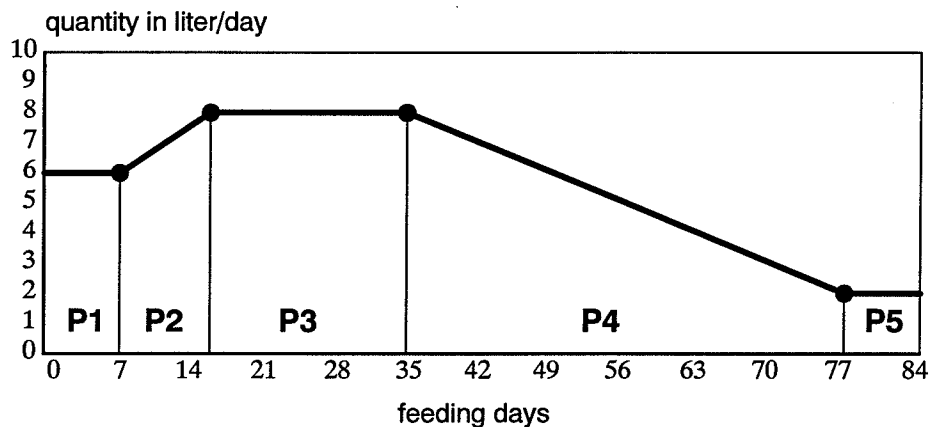

For four groups (A, B, C, D) a feeding plan with 5 periods (P1 - P5) can be entered. (For feeding plans refer also to the appendix of user manual)
The day of registration represents the first day of the feeding plan.

Keyboard



Turn the program switch to 10 = keyboard.

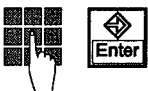

Enter 10 and confirm with ENTER.

```
10# feeding plan
group A^ →
```



Select group.

```
10# feeding plan
group A^ →
```



Go to the next read-out with Arrow Right.

```
10# A per.1 3 days
fr. 6,01 to 6,01 →
```



Press ENTER. Enter the duration of period 1 in days.

```
10# A per.1 4 days
fr. 6,01 to 6,01 →
```



Confirm with ENTER.



Enter the start and end value of period 1 in litres and confirm with ENTER. Values preceding the decimal point must be separately entered and confirmed. The cursor flashes at the relevant spots.

10# A per.1 4 days
fr. 5,01 to 6,01 →



Go to period 2 with Arrow Right.

10# A per.2 14 days
fr. 6,01 to 8,01 →



Enter the duration of the period in days and the end value in litres. Confirm with ENTER. The start value of the period must not be entered. This value was taken over from the end value of the previous period.

10# A per.2 15 days
fr. 6,01 to 9,01 →



Go to the periods 3 to 5 with Arrow Right. Proceed as with the periods 1 and 2.

10# A per.3 18 days
fr. 9,01 to 9,01 →

Following the image of period 5 the total duration of the feeding plans appears:

10# feeding plan
plan lasts 77 days



In the next read-out the plan requirement appears for the drinking volume and the quantity of solid matter, calculated from the feeding and concentration plans. Example with standard values:

10# target consum.
468 l SM: 55 kg

Standard values feeding plan: *(refer also to the appendix of users manual)*

group A: in total 468 l = 77 days

group B: in total 374 l = 70 days

group C: in total 307 l = 64 days

group D: in total 338 l = 71 days

6.1.2 Concentrate-dependent feeding

With automatic weaning according to consumption of concentrate or weight, the feeding plans may be shortened. The start of weaning can be controlled by the level of concentrate consumption. If the four-day average of concentrate consumption (type 1 and 2 together) for a calf exceeds the start value for concentrate-dependent feeding, the calf will be shifted to the beginning of the feeding period. If the calf reaches the end value of the concentrate consumption, it further gets only the minimum of the feeding plan. The duration of the minimum value is determined by the feeding plan.

Example Weaning Förster-Technik

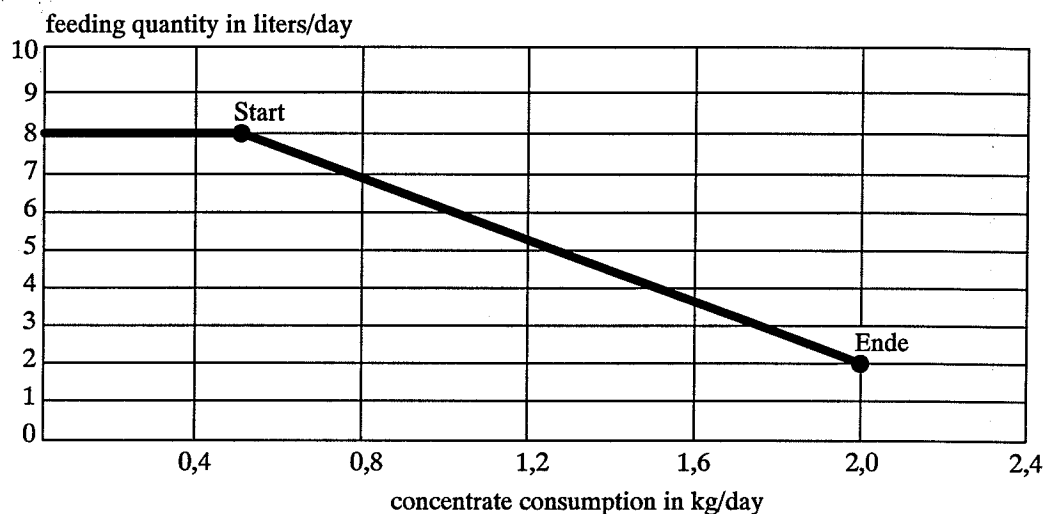

Keyboard



Turn the program switch to 10 = keyboard.

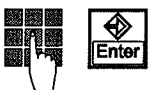

Enter 45 and confirm with ENTER.

```
45# weaning →
    group A^ no
```



Select group.



Enter „yes“ for selected group. Confirm with ENTER.

```
45# weaning →
    group A^ yes
```



Go to the next read-out.

```
45# A start: 0,5 kg
    end: 2,0 kg
```



Press ENTER. Enter start value for the beginning of the feeding.

```
45# A start: 0,6 kg
    end: 2,0 kg
```



Confirm with ENTER.



If the start value is not reached, feeding of the calf according to the settings in the feeding plan will be continued.

If, at the daily calculation at midnight, the four-day average of the concentrate consumption for a calf exceeds the starting threshold value for feeding, the calf will be put at the beginning of the feeding period. Because of the correction days the calf is also shifted back on the concentrate curve.

From now on the drinking quantity will, depending on the concentrate consumption, be recalculated on a daily basis. However, if the concentrate consumption diminishes, the drinking quantity cannot be increased again.



Enter the end value of the feeding. Confirm with ENTER.

45# A start: 0,6 kg
end: 1,8 kg



When a calf during 4 days has reached or exceeded the entered end value, it gets from then on only the minimum of the feeding plan. How long the calf will get the minimum value depends on the feeding plan.

Standard values for weaning by concentrate: start 0,5 kg, end 2,0 kg.

6.2 Concentration plans

For each of the four groups a Concentration Plan, divided into 5 periods can be entered (*refer to appendix*). The periods of the concentration plans are not tied to the periods of the feeding plans. If, for instance, the concentration must remain the same over all feeding periods, only one period, with the corresponding time, needs to be entered.

Keyboard



Turn the program switch to 10 = keyboard.

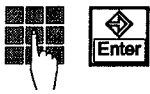

Enter 11 and confirm with ENTER.

```
11# concentr. plan
group A^ →
```



Select group.

```
11# concentr. plan
group A^ →
```



Go to the next read-out and press ENTER.

```
11# A per.1 10 days
fr. 90 to 120g/l →
```

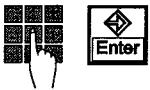

Enter the daily figure into the first period and confirm with ENTER.

```
11# A per.1 12 days
fr. 90 to 120g/l →
```

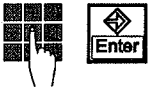

Enter the start and end concentration and confirm with ENTER.

```
11# A per.1 12 days
fr. 80 to 110g/l →
```

Proceed with the periods 2 - 5 as with period 1. The start value of a period equals the end value of the previous value and is taken over from it.



After the image of period 5, information appears about concentration and feeding plan. Example with standard values:

```
11# plan: 77 days
feed. plan: 77 days
```



If the concentration plan is shorter than the feeding plan, the end of the concentration plan appears as a period message. The concentration last fed will be continued until the end of the feeding plan.



In the next read-out the plan requirements appear for drinking volume and the quantity of solid matter, calculated from the feeding and concentration plans. Example with standard values:

```
11# target consum.
468 l SM: 55 kg
```

Standard values concentration plan:
 group A: in total 55 kg MP = 77 days
 group B: in total 41 kg MP = 70 days
 group C: in total 30 kg MP = 64 days
 group D: in total 41 kg MP = 71 days

6.3 Concentrate plans

If two concentrate feeders are installed, two types of concentrate (C 1 and C 2), e.g. Calf-start and farm-based flour mix can be fed (for settings refer to chapter 5.7.1, page 36, „Setup, Activate concentrate“). For each of the four groups, 5 periods are available.

Periods of a concentrate plan
Förster-Technik

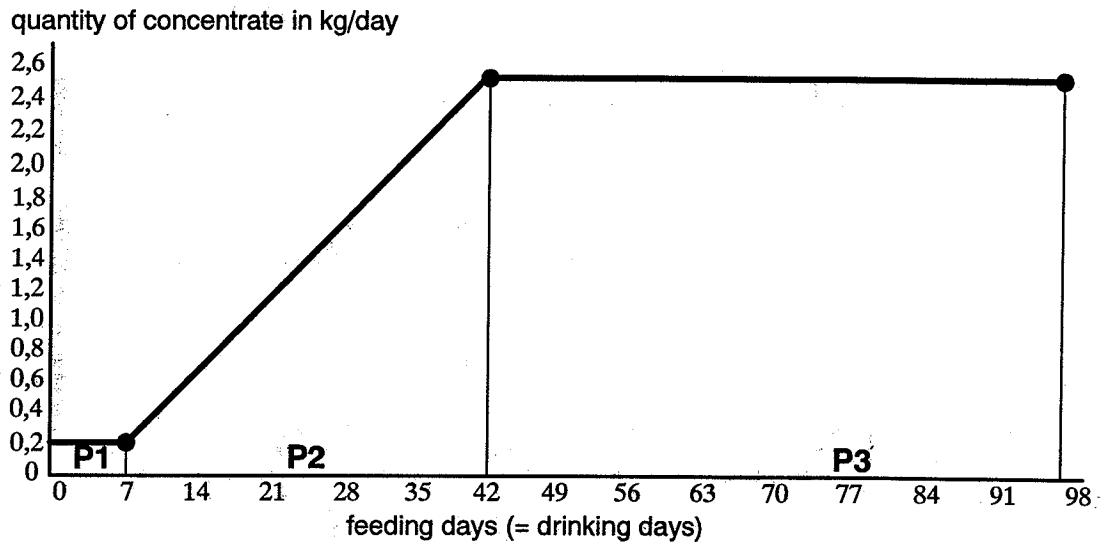

Concentrate plan 1:

Turn the program switch to 10 = keyboard.

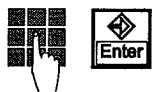
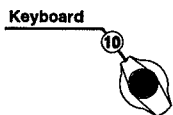

Enter 40 and confirm with ENTER.

```
40# C1-plan
group A^ →
```



Select group.

```
40# C1-plan
group A^ →
```



Go to the next read-out with Arrow Right.

```
40# A per.1 7 days
fr. 0,2 to 0,2kg →
```



Press ENTER. Enter the duration of Period 1.

```
40# A per.1 6 days
fr. 0,2 to 0,2kg →
```



Confirm with ENTER.

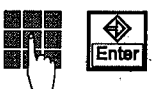

Enter the start and end value of the concentrate quantity in kg (maximum concentrate quantity per type 9,9 kg). Confirm with ENTER.

```
40# A per.1 6 days
fr. 0,2 to 0,5kg →
```



Go to period 2 with Arrow Right.

40# A per.2 42 days
fr. 0,5 to 2,0kg →



Press ENTER and enter the duration of period 2.



Confirm with ENTER.



Enter the start and end value of the concentrate quantity in kg. Confirm with ENTER. The start value of a period need not to be entered. This value has been taken over from the preceding period.



Go to the periods 3 to 5 with Arrow Right. Proceed as with period 1 and 2.

After the read-out of period 5 the duration of the C1 plans and the feeding plans appear. Example with standard values:

40# plan: 90 days
feed. plan: 77 days



The next read-out shows the plan requirement for the C1 quantity. Example with standard values:

40# target consum.
C1: 161 kg

Standard values concentrate plan 1
for all groups :

period 1: 7 days 0,2 kg
period 2: 42 days from 0,2 to 0,5 kg
period 3: 41 days from 0,5 to 2,5 kg
period 4: inactive
period 5: inactive
length of plan: 90 days = 13 weeks

Standard values concentrate plan 2
for all groups :

periods 1 - 5 inactive.

Concentrate plan 2:

Enter keyboard menu 10, 41 and then proceed as for concentrate plan 1.

6.4 Entitlement intervals

The daily feed quantity is divided by the number of entitlement intervals.

Example: If the drinking right of a calf between 0 and 8 p.m. o'clock corresponds to 10 liters, the entitlement (in case 20 entitlement intervals have been entered) will increase in each feeding interval (1 hour) by 0.5 l. But the feed will only be released when the minimum saved quantity has been reached. (*Minimum saved quantity see chapter 6.5, page 77, „Quantity limits“*).

6.4.1 Feeding intervals

Keyboard



Turn the program switch to 10 = keyboard.



Enter 16. Confirm with ENTER.

```
16# feed. interv.
for group A^ →
```



Select the group.

```
16# feed. interv.
for group B^ →
```



Move to the next read-out by Arrow Right. Press ENTER.

```
16# A 1. fr. 0 hrs
last till 20 hrs
```



Enter the period of time for the entitlement intervals. After the last time entry the total feed quantity is available as remaining amount. Confirm with ENTER.

```
16# A 1. fr. 0 hrs
last till 20 hrs
```

You may enter a time between 6 p.m. and 11 p. m. Standard value: 8 p.m.



Move to the next read-out. Press ENTER.

```
16#A feed. interv.
20 entitlem.interv.
```

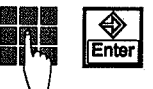

Enter the number of entitlement intervals.
Confirm with ENTER.

```
16#A feed. interv.
32 entitlem.interv.
```

You may enter at least 2, at most 40 entitlement intervals. 20 entitlement intervals are activated for all four groups as standard.

6.4.2 Concentrate intervals

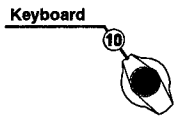

Turn the program switch to 10 = keyboard.

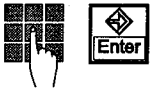

Enter 44. Confirm with ENTER.

44# C intervals
for group A^



Select the group.

44# C intervals
for group B^



Move to the next read-out with Arrow Right. Press ENTER.

44# B 1. fr. 0 hrs
last till 20 hrs



Enter the period of time of the concentrate intervals. After the last time entry the total amount of concentrate will be available as remaining quantity. Confirm with ENTER.

44# B 1. fr. 2 hrs
last till 23 hrs

The entries range from 18 to 23 o'clock. Standard value: 20 o'clock



Move to the next read-out and press ENTER.

44#A C-intervals
20 entitlem.interv.



Enter the number of entitlement intervals. Confirm with ENTER.

44#A C-intervals
32 entitlem.interv.

You may enter at least 2, at most 40 entitlement intervals. 20 entitlement intervals are activated for all four groups as a standard.

6.5 Quantity limits

Quantity limits regulate the supply of drinking and concentrate. They are based on Standard values, with which the automatic calf feeder operates.

Minimum saved quantity:

During the day the drinking quantities are continuously saved in accumulation mode, according to the interval feeding time system. The minimum saved quantity establishes how many drinking portions are saved in accumulation mode, until a drinking ration can be released. In this way the number of meals can be indirectly determined.



During the feeding periods the minimum saved quantities can be established at different levels. As a result of this principle the needs of the animals are widely met. Little calves can at the beginning of the feeding plans at first be served with smaller rations, e.g. 4 x 1.5 litre/day. Later the feeding times should, particularly with calf rearing, be reduced to one feeding time per day, by increasing the minimum saved quantity. The increasing intervals between the feeding times considerably enhance the consumption of concentrate and raw food. At the same time the tendency to mutual sucking will be reduced.

The minimum saved quantity for drinking is entered per group and, in accordance with a minimum-saved-quantity-plan, in litres.

The minimum saved quantity for concentrate is entered per group as a percentage of the daily quantity.



Example: Daily quantity Calf 1A = 1.0 kg, Daily quantity Calf 2A 2.0 kg. If for instance, the minimum saved quantity is 10 %, Calf 1 A only gets concentrate, if the accumulated saving is more than or equal to 200 g.

Maximum quantity:

To prevent excessive feeding or eating, caused by too highly accumulated savings, the claimed quantities will be limited. When the maximum quantity has been reached, the claim will be denied for 2 hours. However, the accumulated quantities will be maintained.

When these two hours have elapsed, the calf in question can claim the remainder, again however, only the maximum quantity. The maximum quantity can also be age-dependently set. As a standard the maximum quantity will always be 0.5 litres in excess of the minimum saved quantity.



Drinking: The maximum quantity for drinking is entered per group and, according to a maximum quantity plan, in litres.

The maximum quantity cannot be lesser than the minimum saved quantity.

Concentrate: The maximum quantity for concentrate is entered per group as a percentage of the daily quantity.

Carry over:

If a calf until the end of the day has not claimed its total quantity, a left-over remains, which can be transferred to the next day. Consequently, the value at day-shift will not be zero but represents the transferred quantity. The remainder, exceeding the carry over, will not be transferred to the next day and is cancelled. The carry over can be coupled with the minimum saved quantity, i.e. the carry over will always be the minimum saved quantity at the highest or can be entered as a percentage of the daily quantity.

6.5.1 Minimum saved quantity and Maximum quantity for drinking

Keyboard



Turn the program switch to 10 = keyboard.

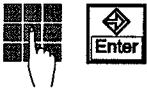

Enter 15 and confirm with ENTER.

```
15# feeding →
amount limits^
```



Select submenu „Amount limits“ or „Carry over“.

```
15# feeding →
amount limits^
```



Go to the next read-out.

```
15# limits →
group A^
```



Select group.

```
15# limits →
group A^
```



Go to the next read-out and press ENTER.

```
15# A per.1 14 days
min:1,51 max:2,01 →
```



Enter the daily number for period 1 and confirm with ENTER.

```
15# A per.1 15 days
min:1,51 max:2,01 →
```



Enter number of litres for minimum saved quantity and confirm with ENTER.

```
15# A per.1 15 days
min:1,71 max:2,01 →
```

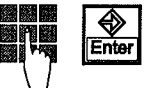

Enter the number of litres for maximum quantity and confirm with ENTER. The maximum quantity cannot be lesser than the minimum saved quantity. Proceed in the next periods (2 - 5) as with period 1.

```
15# A per.1 14 days
min:1,71 max:2,21 →
```



The last read-out shows the duration of the quantity limitation plan and the duration of the corresponding feeding plan.

```
15# plan: 77 days
feed. plan: 77 days
```

Standard values for minimum saved quantity and maximum quantity of the groups A, B, C and D:

	Period	Minimum saved quantity	Maximum quantity
Groups A, B and C	1: 14 days	1.5 l	2.0 l
	2: 14 days	2.0 l	2.5 l
	3: 49 days	2.5 l	3.0 l
	4; 5 standard not activated		
Group D	1: 7 days	1.0 l	1.5 l
	2: 14 days	1.5 l	2.0 l
	3: 14 days	2.0 l	2.5 l
	4: 36 days	2.5 l	3.0 l

6.5.2 Carry over of the drinking



Select submenu „Carry over“.

15# feeding →
carry over^



Go to the next read-out.

15# carry over →
Gr.A^ min.sa.up yes



Select group.

15# carry over →
Gr.A^ min.sa.up yes



Select „yes“ or „no“ and confirm with ENTER.

15# carry over →
Gr.A^ min.sa.up yes



If „Carry over yes“ is selected, the carry over will be coupled with the minimum saved quantity.

If „Carry over no“ is selected, the carry over will not be carried out.

Standard value: Carry over coupled with the minimum saved quantity „no“.

6.5.3 Quantity limits for concentrate

Keyboard



Turn the programming switch to 10 = keyboard.

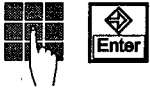

Enter 42 and press ENTER.

```
42# concentrate →
minimum save up^
```



Select submenu „Minimum save up“.

```
42# concentrate →
minimum save up^
```



Go to the next read-out.

```
42# save up →
group A^ 10%
```



Select group.

```
42# save up →
group A^ 10%
```



Press ENTER. Enter minimum saved quantity as a percentage of the daily quantity.



Confirm with ENTER.

Standard value: minimum saved quantity for all four groups 10 %.



Select submenu „Maximum quantity“.

```
42# concentrate →
max. quantity^
```



Go to the next read-out.

```
42# max. quantity →
group A^ 50 %
```



Select group.



Press ENTER. Enter the maximum quantity as a percentage of the daily quantity.



Confirm with ENTER.

Standard value: maximum quantity for all four groups 50 %.

6.5.4 Carry over of the concentrate



Select submenu „Carry over“.

```
15# concentrate →
   carry over ^
```



Move to the next read-out.

```
15# carry over →
Gr.A^ min.sa.up no
```



Select the group.

```
15# carry over →
Gr.A^ min.sa.up no
```

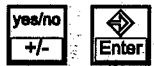

Select „yes“ or „no“ and confirm with ENTER.

```
15# carry over →
Gr.A^ min.sa.up yes
```



If „Carry over, yes“ is selected, the carry over will be coupled to the minimum saved quantity.

If „Carry over, no“ is selected, the carry over will not be carried out.

Standard value: Carry over not coupled to minimum saved quantity, „no“.

6.6 Warning levels

The warning levels determine the warning threshold, i.e., the moment at which a warning is triggered. All warning levels are established per group.

The warnings and types of warnings are extensively discussed in chapter „Warnings“.

Feeding

For feeding there are warning levels for consumption, feeding speed, breaks and robberies.

Concentrate

For concentrate there is a possibility to suppress the concentrate warning for a certain time, because at first little calves do not reliably consume concentrate.

Each type of concentrate has warning levels for early warning, 1-day warning and 3-days warning.

6.6.1 Warning levels for feeding

Keyboard



Turn the program switch to 10 = keyboard.



Enter 20 and confirm with ENTER.

20# warning level →
feeding^



Select submenu „Feeding“.

20# warning level →
feeding^



Go to the next read-out.

20# warning level →
for group A^



Select group.

20# warning level →
for group A^



Go to the next read-out and press ENTER.

20# A consum. 80% →
feeding speed 70%



After „Consumption“ press ENTER again. Following „Feeding speed“ enter the warning level, at which the calf must appear in the warning.



Confirm with ENTER.



Go to the next read-out and press ENTER.

20# A breaks →
no additives 2

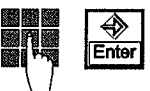

Enter the warning level for breaks without additive. Confirm with ENTER.



Go to the next read-out and press ENTER.

20# A breaks →
with additives 2

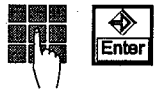

Enter the warning level for breaks with additive. Confirm with ENTER.



Go to the next read-out and press ENTER.

20# A tot.robbery →
frequency 2

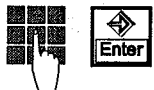

Enter warning level for robbed portions. Confirm with ENTER.

Standard values for all four groups:

Consumption 80 %

Feeding speed 70 %

Breaks without additive 2

Breaks with additive 2

Number robbed 2

6.6.2 Warning levels for concentrate



Select submenu „Concentrate“.

20# warning level →
concentrate^



Go to the next read-out and press ENTER.

20# A for 21 days →
warning suppression



Enter the daily number for warning suppression just after the stabling. Confirm with ENTER.



Go to the next read-out and press ENTER.

20# A C1 8 hrs →
warning today 80 %

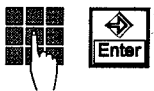

Enter the trigger point for warning today for concentrate type 1. Confirm with ENTER.

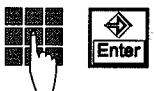

Enter warning level and confirm with ENTER.



Go to the next read-out and press ENTER.

20# A C1 →
day warning 80 %

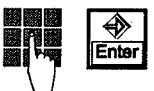

Enter the trigger point for day warning for concentrate type 1. Confirm with ENTER.



Go to the next read-out and press ENTER.

20# A C1 →
3-days-warning 40 %

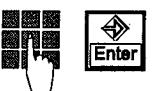

Enter the trigger point for the 3-days warning for concentrate type 1. Confirm with ENTER.



Enter the trigger point for concentrate type 2 into the next three read-outs.

Standard values for all four groups:

Warning suppression: 21 days

Warning today as of 8 o'clock: 80 %

Day warning: 80 %

3-Days warning: 40 %

6.7 Equipment data: station number

The Station number is a plant-related designation of the automatic calf feeder for plants with more than one automatic calf feeder. It is meant for identification of each single automatic calf feeder connected to the PC program „Kalb-Manager“ or to a printer. As automatic calf feeders are factory-delivered with station number „1“, as of 2 feeders you have to change the number accordingly.

Keyboard



Turn the program switch to 10 = keyboard.



Enter 1 and confirm with ENTER.



Go to the second read-out. If the automatic calf feeder has been equipped with a transceiver, the abbreviation „NH“ will appear on the second line of the text display.

```
1# station-No.: 1
PV2-099-NHIVUS-7.00
```

If the automatic calf feeder has been equipped with micro-identification, the abbreviation „ME“ will appear on the second line of the text display.

```
1# station-No.: 1
PV2-099-MEIVUS-7.00
```



Press ENTER. Enter the station number (number between 1 and 25).



Confirm with ENTER.

Standard value: 1

Version: The second line on the display contains the designation for the program version.

Meaning of the characters:

PV2 = Powder with double priority control

099 = a maximum of 99 animals or collars can be managed

NH = Nedap Halsband = Nedap Collar

ME = Mikroerkennung = Micro-Identification

IV = Intervall = Interval Feeding System

US = English Language

6.8 Restricted/Ad Libitum mode

The automatic calf feeder normally operates in restricted mode. However, the automatic calf feeder can be changed to ad libitum mode as well.

Restricted

In restricted mode the automatic calf feeder operates with animal identification, i.e. the calves are reared individually and their data are recorded per animal.

Ad Libitum

In ad libitum mode the automatic calf feeder operates without animal identification. In feeding mode, the next portion will be prepared each time when the sensor in the mixer jar is free. If two sucking stations are connected, both feeding boxes are open. The concentrate feeder dispenses the next portion immediately, in case of an empty bin.

6.8.1 Restricted/ad libitum – mode on automatic calf feeder

Keyboard



Turn the program switch to 10 = keyboard.



Enter 2 and confirm with ENTER.

```
2# restricted yes
   ad lib      no
```



Select „yes“ for restricted drinking or „no“ for ad libitum drinking. Confirm with ENTER.

```
2# restricted yes
   ad lib      no
```



Go to the next item. Here, the information about the feeding quantities of yesterday and today appears.

```
2# today: 12 l →
   ad lib yest.: 234 l
```



Go to the next read-out and press ENTER.

```
2# ad lib →
   concentration 120g/l
```

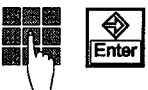

Enter the concentration for the ad lib portion and confirm with ENTER.



Go to the next read-out. Press ENTER.

```
2#   A/Po 0g/l →
   ad lib A/Li 0g/l
```



Enter the quantity of powdery additive and liquid additive for the ad lib portion. Confirm with ENTER.

6.8.2 Restricted/ad libitum mode on concentrate feeders

- Set the slide switch on the Master - card to the desired position.

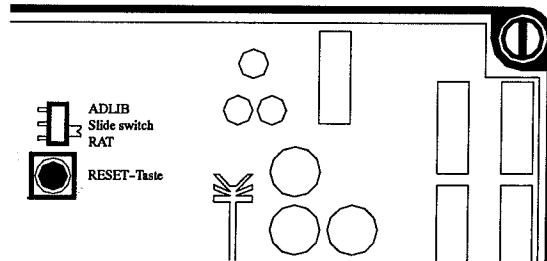

- Subsequently press RESET.

7 Functioning of automatic calf feeder and concentrate feeder

After the calves (A, B, C, D) have been registered in a group, they get drinking and concentrate according to the corresponding plans.

For each calf the concentrate consumption check only starts after a visit to the concentrate station, i.e. here, the relevant animal must at least once be identified. This will avoid small animals, which do not accept concentrate, from continuously appearing as alarm animals.

The actual drinking right or concentrate right will be determined in the interval feeding time system according to the established corresponding plan. The feeding rights are continuously accumulated and demand will be possible at any time when the minimum saved quantity is reached. As of 20 o'clock the total amount of not consumed feed will be available and can be claimed till the daily calculation at midnight.

Interval Feed System – Basic function

Calf with 5 l milk per day, 1,5 l minimum saved quantity and 2,0 l maximum quantity, 20 entitlement intervals, 1 clearing interval

Save up amount in litres

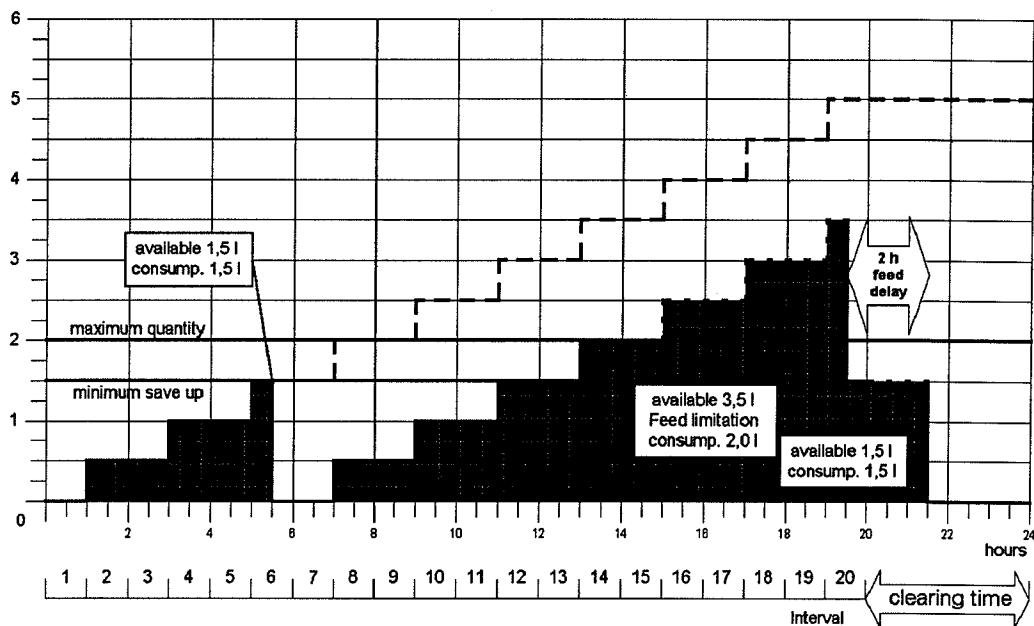

Minimum saved quantity:

The quantity of available food increases continuously during the intervals. To avoid the calves from demanding very small portions, there is the minimum saved quantity, which has to be reached, in order to activate drink distribution or concentrate. When a calf reaches the minimum saved quantity during an interval, this quantity will be released and can be claimed even on several visits.

Carry over:

If a calf, until midnight, did not drink its total allotment or was unable to do so, a rest quantity remains, which can be shifted to the next day. Consequently, at midnight the value will not be zero but corresponds with the transferred quantity. The quantity exceeding the carry over will not be transferred to the next day and will be cancelled.

Maximum quantity:

To avoid excessive drinking or excessive eating by too large accumulation, the quantity to be claimed is limited. When the maximum quantity has been reached, demand will be denied for two hours. In this case, accumulated quantities will not be cancelled.

7.1 Preparation of drinking portions

The drinking preparation starts by liquid transfer. When the liquid jet has reached the supply sensor (short sensor) in the mixer jar, a pre-set powdery portion MP falls from the powder hopper into the mixer jar where it is mixed with the liquid. The mixer is connected to the sucking station by means of a suction hose pipe. At the sucking station the calves can sip the drinking running through the suction hose pipe to the teat.

7.2 Drinking distribution

When the level sensor (long sensor) is free the machine prepares the next portion.

7.2.1 In Restricted mode

Sensor free:

When an animal with drinking right enters the feeding box and is identified, the automatic calf feeder prepares a drinking portion in case the mixer jar is free. Because of the feeding liquid the level sensor (long sensor) will be connected to earth. When the calf has taken its milk, the sensor again gets free and on demand the machine prepares the next portion.

Sensor covered:

When an animal with a drinking right enters the feeding box and is identified, the remaining portion in the mixer will be stirred. When the rest portion has been consumed, i.e. the mixer jar is empty and the sensor free again, the automatic calf feeder prepares a portion.

Two sucking stations:

If an animal with drinking right is identified, the relevant suction line will be opened. If the animal's drinking right ceases, the suction line closes after elapsing of the set feeding time (standard value 16 seconds) and freeing of the long sensor. If the sensor stays covered, the

suction line will be closed after approx. 2 minutes.

After a break, after preparation of the portion the rest quantity in the mixer jar will be released after 5 minutes, i.e. the remaining milk may be consumed by any calf.

7.2.2 In ad lib mode

In ad lib mode the automatic calf feeder operates without neck-band identification. Any time when the level sensor is free the next portion is prepared.

In case of two suction pumps both suction lines are open.



In case of prolonged ad libitum mode the valves of the 2-group valve unit are considerably heated. Therefore, connect the suction hose pipes immediately onto the mixer and loosen the connector at the 2-group valve unit.

7.3 Distribution of concentrate

The concentrate feeder dispenses the next portion, when the dosing flap in the feeding bowl has been released.

7.3.1 Restricted mode

When an animal with feeding right enters the concentrate box and is identified, a portion of concentrate will be dispensed. When the dosing flap is free and the calf still has drinking right, the next portion will be dispensed.

7.3.2 Ad lib mode

In ad lib mode the appliance operates without animal identification. When the dosing flap is free, the next concentrate portion will be dispensed.

7.4 Release of an extra portion

7.4.1 Long sensor free

In switch position „Feeding Mode“ a great deal of portions can be released, if the sensor is free. These portions can neither be deducted from the allotment nor stored by the program.

Feeding Mode



Turn the program switch to position „Feeding Mode“.



Press Start/Stop button. The following read-out will be displayed:

```
extra-portion
0,5l 120g/l start
```



When the Start/Stop button is pressed again, a drinking portion of 0,5 l with a concentration of 120 g/l will be stirred.



The stirred drinking portion can be measured out through the suction line in a container (e. g. a bucket). Take off the suction hose pipe leading away from the mixer jar and put it in the container.



If the portion should be given to a calf in a feeding box, select the box to open the suction line. „0“ means, that no suction line is open. The drinking portion will be released.

```
extra-portion
box: ?
```



The quantity and the concentration of a drinking portion can also be set manually:



Press ENTER to increase the quantity to be distributed and/or alter the concentration of a drinking portion. Concerning the quantity to be distributed it is possible to enter values between 0,5 to 9,5 l (standard value: 0,5 l). The concentration can be varied from 0 to 255 g/l (standard value: 120 g/l).

```
extra-portion
110 g/l
```



Confirm the entries by pressing ENTER.



Press Start/Stop in order to start the preparation of a drinking portion.

If you choose a higher quantity than 0,5 l, the drinking portions will be stirred and released in portions of 0,5 l. If the long sensor is free, the next drinking portion will be stirred and released.



For that reason, never tilt the mixer jar!



After preparation of the first drink portion, select the box to open the suction line. „0“ means that no suction line is open. The drinking portion will be released.

```
extra-portion
box: ?
```

After measuring out all the drinking portions in the vessel the following read-out will appear:

extraportionfinish.
continue with 0/c

Attach the suction hoses again. The operation of the machine remains interrupted until the key 0/c is pressed.

To release any further drinking portions, enter the desired quantity and concentration and press „Start“ once again. If no further entries are made the machine turns back in feeding mode after a few seconds.



On model „TAP1-SA2-27-F“ control the temperature of the drinking portions, in case of high quantities (> 1,5 l) and rapid take-offs of the portions. Resp. wait, until the boiler has restored the temperature. The orange pilot lamp of the boiler water heating has to be extinguished. On model „TAP1-SA2-38-P“, „TAP2-SA2-50-P“, „TAP2-SA2-75-P“ the minimum operational temperature guarantees, that the feeding preparation is interrupted as long as the boiler water heating has restored the temperature.

The take-off of the drinking portions is also related to the entry temperature of the water (summer/winter time).

7.4.2 Long sensor covered

A drinking portion can also be released with covered sensor:

Feeding Mode



Turn to switch position „Feeding Mode“.



Press Start/Stop button.

release restportion
box: ?



Enter the box. The rest portion will be released.

7.5 Feed delay/Delete demand

Feed delay is caused, when animals have claimed their maximum quantity and are then confined for two hours, in order to prevent excess drinking or excess eating. The maximum quantity is entered under keyboard menu 15 = Quantity limitations.

For drinking as well as for concentrate the feed delay and the demand can be deleted separately or per group.

If the demand for drinking or concentrate is deleted, the demand is automatically reset to 0. The animals are, according to the drinking time, entitled to one drinking portion.

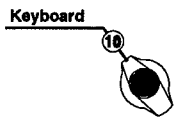

Turn the program switch to 10 = keyboard.



Enter 90 and confirm with ENTER.

```
90# delete  →
      feeding ^
```



Select submenu „Feeding“ or „Concentrate“.

```
90# delete  →
      concentrate ^
```

7.5.1 Delete feed delay



Go to the next read-out.

```
90# feed delay A^ →
delete no ^
```



Select group.

```
90# feed delay A^ →
delete no ^
```



Select „yes“ and confirm with ENTER.

```
90# feed delay A^ →
delete yes ^
```



Go to the next read-out.

```
2A^ feed delay →
delete no ^
```



Select animal.

```
3A^ feed delay →
delete no ^
```

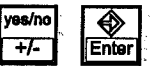

Select „yes“ and confirm with ENTER.

```
3A^ feed delay →
delete yes ^
```

7.5.2 Delete demand for the entire group



Go to the next read-out.

```
3A^consum.group A^→
delete no ^
```



Select group.

```
3A^consum.group A^→
delete no ^
```



Select „yes“ and confirm with ENTER.

```
3A^consum.group A^→
delete yes ^
```

7.5.3 Delete demand for one animal



Go to the next read-out.

```
3A^consum/animal →
delete no ^
```



Select animal.

```
2A^consum/animal →
delete no ^
```



Select „yes“ and confirm with ENTER.

```
2A^consum/animal →
delete yes ^
```

7.6 Daily calculation

Each day at midnight the daily calculation will be started concluding with this event the feeding day. During the daily calculation:

- date, drinking days and remaining days are brought up-to-date until the end of the plan,
- rest quantity is transferred to the next feeding day,
- warnings are calculated,
- weight is recorded with the increase as entered, weight increases automatically by 2 % per day.
- a new calculation of the drinking allotment for the next drinking day is carried out.

8 Check functions

8.1 Displays on switch position „Feeding Mode“

Feeding box without animal:

How many warnings or periods are present:

```
MP mode
dr-warn: 0 exp: 0
```

Whether the machine operates in ad libitum mode and how many litres have been handed out yesterday and today:

```
ad lib yest. 250 l
today 27 l
```

Feeding box with animal:

The display shows which animal is identified at this moment:

```
123A feeding
45,0kg 1,5 l
```

The display shows the current drinking right of the animal that has been identified:

```
123A feeding
45,0kg 1,5 l
```

The current animal weight will only be displayed in case the animal scales have been selected in Setup:

```
123A feeding
45,0kg 1,5 l
```

The display shows whether the sensor is free or covered:

Sensor free / Mixer jar empty

Sensor covered / Mixer jar at least partly filled

```
123A 
```

The display shows whether an animal has been identified and at which feeding box:

≠ = Symbol for identification

1 = Feeding box 1

2 = Feeding box 2

```
123A
≠ 1
```

The display shows whether the drinking right of an animal is limited by the maximum quantity:

```
123A limit. feeding
45,0kg 2,5 l
```

After the calf has claimed the maximum quantity, its drinking right will be blocked for two hours.

The display shows whether the drinking right of the animal has been blocked because the calf has already claimed the maximum quantity:

```
123A feeding
blocked
```



8.2 Animal verification

On switch position 4 = Verification, the feeding behaviour of the calves can be monitored and checked. While on switch position 3 = Warnings, only the warning animals will be displayed, on switch position 4 = Verification all check functions for all calves will be displayed.

Menu „Verification“ contains the following submenus:

- Calves with right
- Feeding behaviour
- C1 and C2
- C1
- C2
- Visit and robbery
- Animal scales
- Number of animals

8.2.1 Calves with right

Menu „Calves with right“ displays all calves which did not claim their drinking right. During the initial feeding the farmer can easily detect calves, which have not yet get used to the automatic feeder.



Turn the program switch to 4 = Verification. The display shows:

```
animal verific.  →
calves with right ^
```



Go to the next read-out. The second line shows the number of calves with current drinking right.

```
calves with right →
number: 6
```



Go to the next read-out. The upper line shows the time of release and the current drinking right. The lower line shows the number of the feeding box, in which the calf has been identified, (if no number appears but a dot instead, the calf has not been identified in neither of the feeding boxes), the day quantity of drinking, as well as today's real drinking right in litres (in brackets).

```
12A fr. 14.00 1,51 →
1(5,5) consu. 2,01
```



Go to the next animal with drinking right.



After the last animal with drinking right has been displayed, the read-out shows the message „No further animals with right“.

8.2.2 Feeding behaviour

Submenu „Feeding behaviour“ displays the values concerning drinking right for today and yesterday, the breaks and the feeding speed. You will find the explanation of „Breaks“ and „Feeding speed“ in chapter 8.3 ff, page 102 ff, „Warnings“.



Select submenu „Feeding behaviour“.

```
Calves with right →
feeding behaviour ^
```



Go to the next read-out. The upper line shows the time of release and the current drinking right. The lower line shows the number of the feeding box, in which the calf has been identified (if no number appears but a dot instead, the calf has not been identified in neither of the feeding boxes), the day quantity of drinking and today's real drinking right in litres (in brackets).

```
12A^fr. 14.25 1,5l →
1(5,5) consu. 2,0l
```

Feed delay

When a calf, which has already claimed the maximum drinking quantity, is in a momentary feed delay, the display shows the following information:

```
1A^ block 110min →
1(6,0) consu. 1,5l
```

The upper line indicates the time remaining in feed delay.
(For the lower line, see previous image).



Go to the next read-out. The upper line indicates the feeding quantity of yesterday. The lower line shows the number of the feeding box, in which the calf has been identified and the real drinking right as a percentage and in litres.

```
12A^ yest. 5,5 →
2/consu. 100%=5,5l
```



Go to the next read-out. The second line shows the number of breaks without additive.

```
12A^breaks,no add. →
today 0 yest. 0
```



Go to the next read-out. The second line indicates the number of breaks with additive.

```
12A^breaks,w. add. →
today 0 yest. 0
```



Go to the next read-out. The second line shows today's feeding speed compared to the 3-day's average and the indication in litres per minute.

```
12A^dr.speed 1/min
today 98% = 1,32 →
```



Go to the next read-out. The second line shows yesterday's feeding speed compared to the 3-day's average and the indication in litres per minute.

```
12A^dr.speed 1/min
today 103%=1,39 →
```

8.2.3 C1 and C2

This submenu displays the information on concentrate, type 1 and type 2.



Select submenu „C1 + C2“.

```
animal verific. →
C1 + C2
```



Go to the next read-out. The first line indicates the total quantity of C1 and C2 available. The second line shows the day quantity of concentrate in brackets and the real total concentrate quantity claimed.

```
5B^ avail. 0,23 →
(0,50) consu.0,09kg
```



Go to the next read-out. The first line shows yesterday's day quantity of concentrate. The second line shows the real claim of concentrate as a percentage and in kilograms.

```
5B^ yest. 0,50 →
consu. 90% =0,45kg
```

8.2.4 Animal verification C1

This submenu shows the information on consumption, the relative consumption compared to the average and the dosing quantity for concentrate type 1.

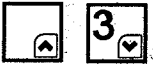

Select submenu „C1“.

```
animal verific. →
C1 ^
```



Go to the next read-out. The first line shows the quantity available of C1. The second line shows the day quantity and the real consumption in kg (in brackets).

```
5B^ avail. 0,12 →
(0,30) consu.0,10kg
```



Go to the next read-out. The first line indicates yesterday's day quantity. This is shown by the percentage in the second line indicating the real consumption of the previous day, put in per cent and in kilograms.

```
5B^ avail. 0,30 →
consu. 90% = 0,27kg
```



Go to the next read-out. The second line shows the quantity consumed today by the animal, compared to the average in kilograms and per cent.

```
5B^ C1 today →
cons. 0,12kg=85% v.φ
```



Go to the next read-out. The second line shows the quantity consumed yesterday by the animal, compared to the average of the last 3 days, in kilograms and per cent.

```
5B^ C1 yesterday →
cons. 0,13kg=93% v.φ
```



Go to the next read-out showing the dosing amount per portion.







```
5B^ dosing amount
1 g
```

8.2.5 Animal verification C2

This submenu displays the information on consumption, the relative consumption compared to the average and the dosing quantity for concentrate type 2. The read-outs for C2 correspond to those for C1.







8.2.6 Visit and robbery

This submenu shows the information on the number of portions robbed, the visits to the feeding boxes and the concentrate box. („Robbery“ is explained in chapter 8.3 ff, page 102 ff, „Warnings“).

		Select submenu „Visit and Robbery“.	<pre>animal verific. → visit & robbery ^</pre>
		Go to the next read-out. The second line shows the number of portions robbed, today and yesterday.	<pre>12B^tot.robberies → today 0 yest. 0</pre>
		Go to the next read-out. The second line indicates the number of visits with drinking right (today and yesterday) to the feeding box.	<pre>12B^ visits fed → today 3 yest. 4</pre>
		Go to the next read-out. The second line shows the number of visits without drinking right (today and yesterday) to the feeding box.	<pre>12B^visits not fed→ today 4 yest. 7</pre>
		Go to the next read-out. The second line indicates the number of visits with drinking right (today and yesterday) to the concentrate box.	<pre>12B^visit with C → today 6 yest. 9</pre>
		Go to the next read-out. The second line shows the number of visits without drinking right (today and yesterday) to the concentrate box.	<pre>12B^visits not fed→ today 3 yest. 6</pre>

8.2.7 Animal scales

In the submenu „Animal Scales“ you may view all information on the animal scales.

		Move to the menu „Animal Scales“ by means of Arrow Up or Arrow Down.	<pre>animal verific. → animal scales^</pre>
		Move to the next read-out with Arrow Right.	<pre>3A^ anim. weight → examine in list</pre>
		Select the animal whose weight has to be checked by means of Arrow Up or Arrow Down.	
		Move to the next read-out with Arrow Right. The first line shows the number of visits to the feeding box of the animal	<pre>3A visit today 2^ num:6 w: 38,0kg →</pre>

selected. The display always shows the last visit with the current animal weight. The second line indicates the number of weighing used to calculate the animal weight, as well as the weight of the corresponding animal resulting from it.



Press Arrow Up or Arrow Down to check the weights determined during the corresponding visit.



Move to the next read-out by means of Arrow Right. The display shows the day-weight of yesterday or the day before yesterday of the corresponding animal. The day-weight results from the weights determined during the visits of yesterday or the day before yesterday.

```
3A day weight
yesterd^ w:151,0kg
```



Press Arrow Up or Arrow Down to view by turns the day weight of yesterday and the day before yesterday.

8.2.8 Number of animals

This submenu shows the number of animals registered and how many numbers are still available, as well as the number of animals registered per group.



Select submenu „Number of animals“.

```
animal verific. →
number of animals
```



Go to the next read-out. The display shows the number of the animals registered and how many numbers are still available.

```
registered: 24 →
available: 5
```



Go to the next read-out. The display shows the number of the animals registered per group.

```
registered calves
group A^: 12
```



Select the group. After a short calculation time, the read-out indicates the number of animals for the group selected.

8.3 Warnings

On switch position 3 = Warnings, the data derived from the drinking behaviour appear, i.e. the generated animal data causing a warning because of warning levels. All warnings belong to a specific animal.

On switch position 4 = Verification, the data of all calves can be consulted.

8.3.1 Drinking warnings

Actual warning If during the day a calf does not claim its available quantity within 3 hours after release, it appears in an actual warning.

Actual warnings can only temporarily be deleted by pressing „0/C“, they reappear at switch position Feeding Mode, because the reason for the warning is still existing. Actual warnings disappear automatically, if the wrong quantity has been cancelled.

Day warning The day warning is detected at the daily calculation and appears for calves, which have reached the warning level. The day warning is yesterday's value.

The day warning must be deleted by key 0/C.

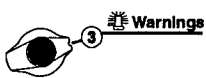

Turn the program switch to position 3 = Warnings.

```
messages:^ dr:2 →
C:0 GW: exp:0
```



Select submenu „Warning animals“.

```
warning animals^ →
feeding: 2
```



Go to the next read-out.

```
1A^ fr. 9.30 2,01 →
1(6,0) consu.0,01
```

Actual Warning At an actual warning the time of release and the accumulated saving in litres appear at the upper line. The lower line firstly shows the number of the drinking station, in which the calf has been identified (if no number appears but a dot instead, the calf was not identified in either of the drinking stands). Subsequently, the daily drink quantity and the real drinking right in litres appear in parentheses.

```
1A^ fr. 9.30 2,01 →
1(6,0) consu.0,01
```

Feed delay If, after claiming the maximum quantity, a warning calf is at that moment in feed delay, the upper line shows the remainder of the feed delay.

```
1A^ block 110min →
1(6,0) consu. 1,5 1
```

Day warning At day warning yesterday's drink quantity appears in the upper line. The lower line firstly shows the number of the drinking station, in which the calf has been identified. Subsequently, the real drinking right as a percentage, followed by the real drinking right in litres appears. This calf appears for instance in the day warning, because yesterday it took 50 % of its daily ration.

```
2B^ yest. 6,0 →
2/consu.50% = 3,0 1
```

8.3.2 Breaks

A break is caused by a calf, which has left the box with the mixer jar still not empty or if the calf did not consume its portion after 2 minutes. So the breaks supply information about calves not actually having consumed their daily ration.

Breaks are divided into breaks with and without additives, in order to determine, whether the addition of an additive could be the cause, that the calves did not consume their portions.

After a break the remainder in the mixer jar is released 5 minutes after preparation of the portion, i.e. the remaining milk can be retracted from each calf.

The lower line of the display shows the actual warning (today) and the day warning (yesterday). This calf appears for instance as a warning calf, because yesterday it had 2 breaks without additive and today 1 break without additive.

```
1A^ breaks, no add. →
today 1 yest. 2
```

8.3.3 Feeding speed

If animals do no longer consume their drinking quantity, their general health condition has already considerably deteriorated. Particularly with older animals, which already get fewer drinking, the claim for food can no longer be considered as the only indication of their healthiness.

Reduction of the feeding speed may be an indication for deterioration of their general health condition. If the feeding speed of many or of all animals deteriorates, it may have another cause, e.g. an obstructed suction hose, souring milk, changing temperature of the drinking, new teats, etc..

The feeding speed is measured per animal. The actual feeding speed will be compared to the average of the last three days. The daily average is 100 %. As it lasts three days before the 3-day's average has been calculated, there will be no feeding speed warning message in the first three days.

Actual Warning

The lower line of the display shows the actual feeding speed (today) as a percentage of the 3-day's average and the value in litres per minute. This calf, for instance, appears as a warning calf, because today it drank slower than usual and below the warning level of e.g. 80 %.

```
1A^ dr. speed 1/min
today 72% = 0,82 →
```

Day warning

The lower line of the display shows yesterday's feeding speed as a percentage of the 3-day's average and the value in litres per minute.

```
12A^ dr. speed 1/min
yest. 78% = 0,94 →
```

8.3.4 Robbers

„Robbers“ are calves, trying to get hold of remaining portions. If a calf is repeatedly pinpointed as a robber, it should perhaps be removed from the group. The closing valve or the 2-group valve control unit offer the advantage of opening only, if the calf is entitled to feeding. Although the robber will be registered as such, it gets no drinking.

On the lower line the actual warning (today) and the day warning (yesterday) appears.

```
15B^tot.robberies →
today 1  yest. 2
```

8.3.5 Additive warning

If a calf has emptied the mixing jar, before the entire additive quantity was dosed, the warning message „Long dosing time .. s“ appears.

```
17C^ A/Po-warning
long dosing-time..s
```

If with a dosed quantity the minimum value stays one gram below, a warning message appears:

```
17C^ A/Po-warning
dosing-am. only ..g
```

8.3.6 Unknown Responders

If a Responder number was read, which could not be tracked down to an animal number (neck-band number), or a responder was read, not belonging to a registered animal number, this number will be registered.

In the example the responder number 1234 of collar number 100 was read, thus the animal was not registered. If only the responder number has appeared, it was impossible to assign it to any animal at all.

```
unknown resp.
No: 1234      100a
```



If „Automatic Registration“ has been activated, each available number will automatically be registered.

8.4 Concentrate warnings

- Warning today** The warning today is determined by the warning threshold and appears as of a certain time for calves, which took too little of their food. The warning today disappears automatically, when the calf fetches its allotted feed portion.
The warning today can only temporarily be deleted, it reappears at switch position Feeding Mode, because the reason for the warning message is still existing.
- Day warning** The day warning is an animal-specific determined warning, which compares the claim of the day to the 3-day average of the claims.
The day warning is determined at the daily calculation and appears for calves, which did not reach the warning level. The day warning is yesterday's value.
- 3-day warning** If the average of the claim of the last 3 days, compared to the value of the concentrate plan, lies below the warning level, the calf appears in the 3-day warning.



The 3-day warning must be erased by pressing key 0/C.



If a calf appears in day warning, there will be no 3-day warning.

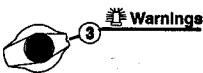

Turn the program switch to 3 = Warnings.

```
messages:^ dr.:1 →
C:2 exp:0
```



Select submenu „Warning animals C“.

```
warning animals^ →
conc: 2
```



Go to the next read-out.

```
1A^ C1 warn.today →
cons. 0,23kg=62%f.φ
```

Warning today The upper line shows the warning today for type 1 or type 2. The lower line shows the claimed quantity in grams and the related percentage of the 3-day's average.

```
1A^ C1 warn.today →
cons. 0,23kg=62%f.φ
```

Day warning The upper line shows the day warning for type 1 or type 2. The lower line shows yesterday's claimed quantity in grams and the related percentage of the 3-day's average.

```
1A^ C1 yesterday →
cons. 289g=75%f.φ
```

3-day warning The upper line shows the 3-day warning for type 1 or type 2. The lower line shows the percentage of the plan setting.

```
1A^ C1 3-days-warn
75% fr. plan value →
```

8.5 Dates of expiry

Animals, of which a time-limited action (e.g. addition to drinking quantity) has been expired, appear as Expired Animals with the expiry date message for that relevant occurrence.

Expiry date messages must be erased with key 0/C. The expiry date messages for a running cycle of the feeding plan and the concentrate plan reappear after each day shift, until the animal has been cancelled.

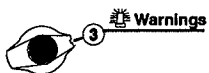

Turn the program to 3 = Warnings.

```
messages:^ dr.:0 →
C:2 exp:2
```



Select the submenu „Expired plan/animals“.

```
exp.plan/animal^ →
number: 2
```



Go to the next read-out.

```
23A^ feeding →
expiry date reached
```



Delete period messages with the 0/C key.



Go to the next read-out.



Expiry date messages for the end of the feeding plan appear daily, until the animal will be cancelled.

The following expiry date messages may appear:

End of feeding plan: At the end of the feeding plan, calves get no drinking anymore. Expiry date messages can only be deleted for one day. The next day they reappear, until the animal has been cancelled.

```
23A^ feeding
expiry date reached
```

End of concentration plan: At the end of the concentration plan, calves get a prolonged concentration.

```
23A^ concentration
expiry date reached
```

End of concentrate plan: At the end of the concentrate plan, calves get a prolonged concentrate quantity. After erasing, the expiry date message reappears the next day, until the animal has been cancelled.

```
23A^ C1
expiry date reached
```

End of additive plan: At the end of an additive plan, calves get no additive anymore.

```
11A^ add. powder
expiry date reached
```

```
11A^ add. liquid
expiry date reached
```

End of an addition/reduction:

The calf returns to the feeding plan.

12C^ feeding
+/- deviation exp.

The calf returns to the concentration plan.

12C^ concentration
+/- deviation exp.

The calf returns to the concentrate plan.

14A^ C1
+/- deviation exp.

17B^ C2
+/- deviation exp.

The calf returns to the quantity prescribed by prescription or plan.

13A^ add. powder
+/- deviation exp.

13A^ add. liquid
+/- deviation exp.

8.6 Animal data and Info

In switch menu „Animal data and Info“ you may enter the Responder number and register, cancel and relocate the calves. The most important animal data as for instance increase in weight, stabling date as well as the days until the end of the feeding plan can be entered and checked.

The switch menu „Animal data and Info“ consists of the following submenus:

- Weight, feeding days
- Daily ration/Animal
- Cancellation
- Registration
- Registration of groups
- Automatic registration
- Change registration
- Responder input

8.6.1 Weight, Feeding days

This menu shows the data for weight and the daily increase and information about feeding days, stabling dates, correction days and the days until the end of the plan.



Animal Data & Info

Turn the program switch to 6 = Animal data and Info.



Select submenu „Weight, Feeding days“.

```
animal data &Info →
weight, days fed ^
```



Go to the next read-out. Here, the animal weight and the actual daily increase are checked and, if necessary, altered.

```
12A^ weight 55 kg →
LWG 370 g/day
```



In case no reliable animal weight could be ascertained, the display shows:

```
12A^weight 55 kg? →
LWG 370 g/day
```



Press ENTER and, if required, alter the animal weight and the daily increase.



Confirm with ENTER.



The weight increases daily by 2 %, because bigger calves increase more quickly than the smaller ones.



Go to the next read-out showing the feeding days (days since first stabling) and the stabling date. Here, the animal number can only to be entered or changed respectively.

```
12A^ days fed 12 →
reg. date 12.09.97
```



Go to the next read-out. By entering the correction days, each calf can be placed on each point of the relevant curve.

```
12A^corr. +0 days →
expires in 43 days
```



Press ENTER. Enter the required correction days.



Confirm with ENTER.



Positive numbers: By entering positive numbers, the calves are made older and shifted to the right on the feeding curve.

Negative numbers: By entering negative numbers, animals are made younger and shifted to the left on the feeding curve. An animal cannot be placed on a point preceding the start of the curve. So, if the negative number is larger than the number of feeding days, the entry will not be accepted.

End of the feeding plan: The days until the end of the feeding plan are always calculated with actual data. So, the setting changes after entering of correction days. After reaching the end of the plan, drinks are no longer handed out, unless an animal gets an additive. According to the duration of the recipe, a prolonged distribution of the drinking takes place. Animals, which got their share, have to be made younger and **not** registered as new!



Go to the next read-out.

12A^ C1 - plan →
expires in 55 days



Go to the next read-out.

12A^ C2 - plan →
expires in 62 days

Information appears about the remaining feeding days, until the end of the plan for the concentrates type 1 and 2. After reaching the end of the plan, concentrate will from then on be fed according to the last plan value.

8.6.2 Daily ration/animal

This menu shows the information about the composition of the drinking and the concentrate quantity per animal and the actual day.



Select submenu „Ration/Day/Animal“.

```
animal data & Info →
ration/day/animal^
```



Go to the next read-out. Information appears about the feeding quantity per day and the quantity of concentrate (C1 and C2 together).

```
12B^ feed. 6,0 l →
C 0,20 kg
```



Go to the next read-out. Information appears about the daily quantity of drinking and their concentration.

```
12B^ feed. 6,0 l →
concentr. 110 g/l
```



Go to the next read-out. Information appears about the quantity of milk powder per day.

```
12B^ →
MP 120 g
```



Go to the next read-out. If a powdery additive is fed, the daily quantity for the selected animal and the already consumed quantity appear here.

```
12B^ A/Po.R1 20 g →
consumed 10 g
```



Go to the next read-out. If a liquid additive is fed, the daily quantity for the selected animal and the already consumed quantity appear here.

```
12B^ A/Li.R6 12 g →
consumed 6 g
```



Go to the next read-out.

```
12B^ C1 0,23 kg →
(0,19)kg
```



Go to the next read-out.

```
12B^ C2 0,48 kg →
(0,35)kg
```

The first line shows the information about the daily quantity of concentrate type 1 or type 2 with a possible rest quantity transfer. On the second line the value from the plans C1 or C2 appears.

8.6.3 Cancellation

If animals are removed from the stable, they must always be cancelled. After cancellation, the animal numbers are available again and the animal number will be followed by a small „a“.

In this menu individual or all animals can be cancelled (before and after the feeding plans).



Before removal from the stable make a note of the economic data, e.g. feeding days and consumption totals. Remove cancelled animals from the stable.



If automatic registration has been activated, the animals are to be removed from the stable before cancellation, otherwise, there is the possibility of automatic renewed registration.



Select submenu „Cancel Registration“.

```
animal data &Info →
cancel registrat. ^
```



Go to the next read-out. The second line shows the remaining days until the end of the feeding plan for the relevant calf.

```
14A^cancel ? no →
expires in 59 days
```



Select the animal number to be cancelled.



Select „yes“ and confirm with ENTER. The following message appears:

```
14v^ is cancelled
```



Go to the next read-out. In this image all animals, having finished the plan, can be cancelled.

```
all expired animal →
cancel reg. ? no
```



Select „yes“ and confirm with ENTER. A message appears about the number of cancelled animals and how many animal numbers are now available.

```
animals cancelled:3
numbers available12
```



Go to the next read-out. In this image all animals can be dismissed.

```
all animals →
cancel reg. ? no
```



Select „yes“ and confirm with ENTER. A message appears about how many animals have been cancelled and how many animal numbers are now available.

```
animalscancelled:26
numbers available35
```

8.6.4 Change registration of animals

In menu „Change registration“ the group can be changed for each animal.



Select submenu „Change registration“.

```
animal data &Info →
change registrat. ^
```



Go to the next read-out. The second line contains the remaining days until the end of the plan, just for information.

```
10B^change into A^→
expires in 42 days
```



Select animal number.



Confirm with ENTER.



Select the desired group.



Confirm with ENTER.

8.7 Consumption

On switch position 8 = Consumption the total need for each feeding component (MP, additives and concentrate) will be calculated per day and per appliance.



Turn the program switch to 8 = Consumption. The first image shows the calculated milk powder requirement for all calves in kilograms and the indication of the kilograms already consumed.

MP req.	5,8 kg	→
consumed	0,0 kg	



The following images appear, if powdery or liquid additives are dispensed.



Go to the next read-out. The daily need for additives for the actually active recipe, calculated after the animals and their weight appears and the indication of grams already consumed.

A/Po.R1	req:27g	→
consumed	5g	



Go to the next read-out. The daily need for additives for the actually active recipe, calculated after the animals and their weight appears and the indication of grams already consumed.

A/Li.R6	req:65g	→
consumed	23g	



Go to the next read-out. The calculated need for concentrate type 1 for all calves appears in kilograms and the indication of kilograms already consumed.

C1	req 12,5kg	→
consumed	3,6kg	



Go to the next read-out. The calculated need for concentrate type 2 for all calves appears in kilograms and the indication of kilograms already consumed.

C2	req 19,1kg	
consumed	5,2kg	

8.8 Consumption totals

In „Consumption totals“ the total quantities of milk powder, concentrate and additives consumed till now, appear for each animal.

Keyboard



Turn the program switch to 10 = keyboard.

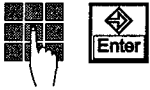

Enter 22 and confirm with ENTER.

1A^	→
MP	9,8 kg



Select the animal. The consumption totals for milk powder of the relevant calf appear.

2A^	→
MP	8,6 kg



The next read-out shows the consumption totals for powdery and liquid additives.

2A^	A/Po	25 g	→
	A/Li	0 g	



The next read-out shows the consumption totals for the concentrate types 1 and 2.

2A^	C1	12,5 kg	→
	C2	21,2 kg	

9 Cleaning

9.1 Mixer cleaning (mixer without automatic cleaning)

To clean the mixer without rinsing device, select menu „Cleaning mixer“. After activation the water in the mixer jar will be stirred for 3 minutes.



If automatic cleaning was activated in the „Setup“, automatic cleaning is selected in this read-out.

- If no valve control is present, take off the suction hoses from the teat and hang them up. This prevents a calf from drinking liquid from the mixer jar.

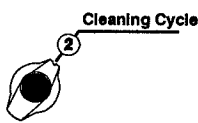

Turn the program switch to 2 = cleaning.

```
cleaning mixer →
3:00 min start
```



Press the Start/Stop button. The mixer runs for 3 minutes.

Functioning:

When the sensor gets free after pressing the Start/Stop button, a water portion is released. After 20 seconds a second water portion will be released. Subsequently, the mixer runs for 3 minutes.

If the sensor is covered, the mixer runs for 3 minutes.

- If necessary, add some cleaning agent as used in dairy industry.

When mixer cleaning has finished, the message „Finished“ appears on the second line of the display.

```
cleaning mixer
finished
```

- Tip the mixer over and empty it.
- Push the suction hoses on the teats.
- With the button manual operation „Water“ pump clear water into the mixer jar.
- Drain the water through the suction hoses.
Open the suction lines on machines with a 2-group valve unit, if they are not already open:



Press key 1/Esc to open suction line 1.



Press key 2, to open suction line 2.

9.2 Automatic mixer cleaning (time-controlled)

Mixers with a device for automatic cleaning can be automatically rinsed up to nine times a day.



Automatic cleaning must be activated in the „Setup“.

The mixer must have an automatic cleaning device and be connected to a valve control (2-group valve unit or stop valve).

For practical reasons the automatic calf feeder should have a nearby water drain. If there is no water drain present, the mixer drain hose must hang in a bucket.



Empty the bucket regularly. Do not immerse the mixer drain hose into the cleaning water.

Functioning:

When the long sensor is free, the mixer jar is filled with 2 water portions. The mixer runs for 3 minutes. The display gives the message „Mixer Pre-Cleaning“.

Then, the mixer jar is filled with a third water portion, so that the overflow is reached and cleaning water drains off entirely. The display shows the message „Emptying Mixer“. After a short time the mixer jar is once again filled with 2 water portions and the cleaning cycle is repeated, but this time shorter. The display gives the message „Post-Clean Mixer“.



If the water does not drain off after the overflow portion within one minute (the long sensor is not freed), an alarm message („Clean alarm“) follows. This alarm message can be consulted and deleted in key menu 24 „Device alarms“. Check whether the overflow tube of the mixer is obstructed. The valve control opens the suction hoses, in order to drink the mixer empty and drinking can be continued.



If the sensor is covered, automatic cleaning is carried out, as soon as the long sensor is freed.

9.3 Call up Automatic mixer cleaning manually

Automatic Mixer Cleaning can be activated in the cleaning menu at any time.

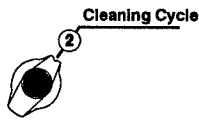

Turn the program switch to 2 = Cleaning.

cleaning mixer	→
3:00 min start	



In case the long sensor is uncovered, press the Start/Stop button.
Automatic Cleaning is now carried out.



When the program switch is turned with running mixer, the third portion is only handed out after turning the program switch to „Cleaning“ or „Feeding Mode“.

- If necessary add some cleaning agent as used in dairies.

Feeding Mode



After termination of the automatic cleaning cycle, turn the program switch to position 1 = Feeding Mode.



The switch may only be turned to „Feeding Mode“, if no cleaning agent was added, or only when the water with the cleaning agent has drained.

10 Service and maintenance

10.1 Service and maintenance of the automatic calf feeder

- Always keep the automatic calf feeder clean and dry. Never use a water jet!



- Observe the correct position of the sensor.

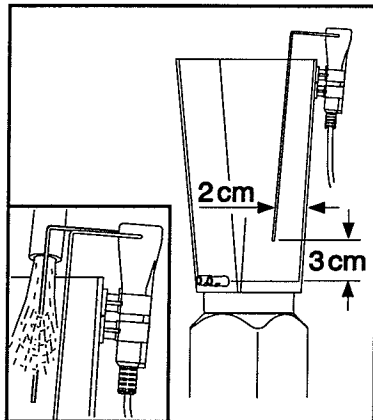

- Keep the sensor shaft and clamps clean and dry. Wetting of these parts causes earthing of the sensor and makes preparation of the next portion impossible.

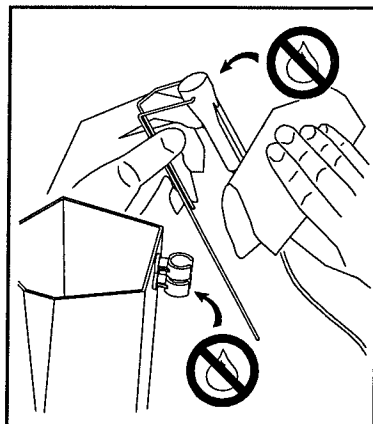

- Daily check the powder eject opening and, if necessary, remove sediment.
Sediments have a detrimental effect on the dosing precision.



Because of injury risks, always remove incrustations on powder outlet by means of a small piece of wood or something similar. Never use your fingers!

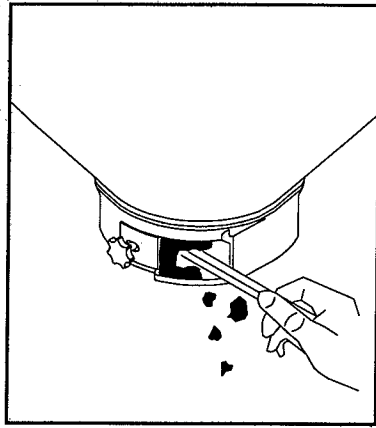

- Clean the mixer jar every 1 - 2 days.

10.1.1 The day after the first starting

- Function check:
 - Check the calibration values.
 - Measure the temperature of the drinking.
 - Check the response of the external devices by means of the hand-operation keys.
 - Make sure that animals are reliably identified.
 - Check the operational data (feeding plans, concentration plans, maximum/Visit, alarm level).
 - Check the entries under Recipes and Additive Plans. Check the activation of the dispense of additives.
 - Check the entries of weights and the daily increase.

10.1.2 Carry out a regular check routine

- Measure the temperature of drinking with a precision thermometer.
- Check calibration of the milk powder at least after each new delivery.
- Check water calibration.

10.1.3 Shut-down

Before shut-down:

- Turn the thermostat for minimum operationing temperature (available as an option on model „TAP1-SA2-27-F“) and the heating thermostat entirely counter clockwise.
- Switch off the calf feeder with the main switch (turn to „OFF“) or at model „TAP1-SA2-27-F“ turn off the flip-switch and pull the mains plug.
- In case the calf feeder should not be used, some water may flow out, even if the water inlet is provided with a non-return valve.

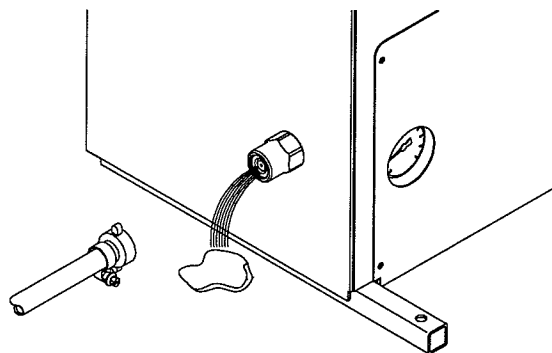

In case of frost risk:

- Take off the boiler hose and drain the water off the boiler.
- Drain the water off the solenoid valves and the presssure reducer. Remove the pressure reducer and drain off the water. Remount the pressure reducer and reconnect the boiler hose.

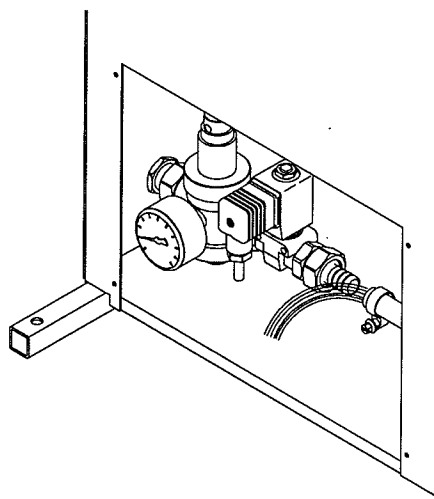

After shutdown:

- Keep the automatic calf feeder in a dry place.
- Keep the connections on the control unit closed by means of closing caps. If not, moisture could penetrate the control unit.

Renewed starting:

- When starting the feeder again, check whether there is enough water in the boiler.
- Proceed as for first starting.

10.2 Service and maintenance of the concentrate feeder

Daily:

- Check the level in the concentrate container and fill if necessary.
- Check the concentrate bowl for food rests and clean, if necessary.
- Keep the dosing flap clean and free from food rests.
- Check whether the LED of the feed contact lights up, when the feed bowl is empty.

Regularly:

- Regularly carry out the calibration for concentrate.
- At least after a new delivery of concentrate or fresh flour or coarse food the calibration must be checked.

Shutdown:

- Empty the concentrate feeder and remove food rests.
- Dry the concentrate feeder and store it in a clean place.
- Proceed as for first starting.



Never use a water jet on electrical parts!

11 List printing

Under keyboard menu 10 = „Print list“ a connected printer can at any time print a warning list and a verification list of the calves. Information about the printer connection can be found in the appendix of the user manual.

Warning list The Warning list shows all warning animals with the relevant warning messages. Two lists will be printed: one for the feeding warnings and one for the concentrate warnings.

Verification list The printed Verification list shows the drink allotment for all animals, claims and feeding speed.

Keyboard



Turn the program switch to 10 = keyboard.

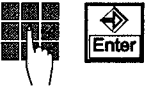

Enter 21 and confirm with ENTER.

```
21# print list  →
warning list no
```



Go to the relevant read-out of the required list with Arrow Right. Example:

```
21# print list  →
verific. list no
```

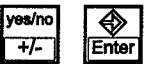

Select „yes“ and confirm with ENTER. Printing starts immediately.

12 Error messages

The automatic calf feeder and the concentrate feeder are continuously monitored by the processor control. Errors appear on the display.

12.1 Check the calibration values for drinking

If one or more calibration values are missing, the display shows:

```
calibration values
adjust !!!
```

- Calibrate again.

12.2 Feeding interrupted

If feeding is interrupted because the minimum operating temperature was too low, the display shows:

```
check temperature
```

- Check the position of the thermostats.
- Check the heating.

12.3 Data destroyed

In case of destroyed data a beep sounds. This message occurs very seldom and after extremely intensive interference on the control. When this message appears, „New installation, all new“ must be carried out.

```
data destroyed
press key 0/c
```



Press key 0/C. The display shows „Data destroyed, new installation yes“. Refer to chapter 5.6.2, page 34, „Starting: New Installation“.

```
data destroyed
new installationyes
```



Select „yes“ and confirm with ENTER. A warning appears:

```
instruction manual
read? yes
```



Select „yes“ and confirm with ENTER.



All data will be erased and the operational data will be overwritten by standard values!

- Subsequently, proceed as for first starting.

12.4 Water shortage

If the supply sensor is not hit in water mode, the automatic calf feeder starts a Water test. To this end, the repetition feature will try 5 times, whether the water really does not emerge. After trying 5 times in vain, the preparation of drinking and the animal identification will be switched off.

The display shows in feeding mode:

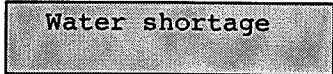

Water shortage

- Check whether the short sensor is hit by the water jet.
- Check the water supply to the automatic calf feeder.

12.5 Clean alerts

If the automatic calf feeder has been equipped with automatic rinsing and after dispense of the third portion (overflow portion), the mixer jar is not empty, a clean alert will be generated.

This message could be for instance:

On the first line appears the frequency of the clean alerts.

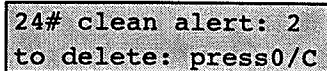

24# clean alert: 2
to delete: press0/C

- Check the overflow tube of the mixer rinsing device and if necessary, clean it.
- Check the position of the sensor.
- Check the water calibration.

12.6 Mains interruptions/Restoring from backup/Water checks

Keyboard



Turn the program switch to 10 = keyboard.



Enter 23 and confirm with ENTER. In this read-out, new program starts of the automatic calf feeders can be checked (e.g. after a Mains interruption). The displayed date is the date of the last deletion.

```
23# power failure →
seit 09.09.97 2
```



Press key 0/C, to reset the number of mains interruptions to 0 and to actualise the date.



Go to the next read-out. The mains interruptions for the concentrate stations 1 and 2 appear.

```
23# silo 1&2 →
mains interr.: 0
```



Go to the next read-out. The mains interruptions for the concentrate stations 3 and 4 appear.

```
23# silo 3&4 →
mains interr.: 0
```



Go to the next read-out. After a detected data error in the memory the computer can fall back on an internal backup. Each restoration from backup will be counted.

```
23# restore
since 04.03.97
```



Press key 0/C, to reset the restorations to 0 and to actualise the date.



If restoration from backup occurs regularly, find the cause of the error!



Go to the next read-out. The number of water checks since the indicated date appears. A water check will be carried out, if the sensor was not or not long enough hit by the water jet.

```
23#water check-up →
since 01.03.97 4
```



Press key 0/C to reset the number of water checks to 0 and to actualise the date.

12.7 Error in concentrate mode and with scales connection

If errors occur in concentrate mode, the feeding mode will be sustained. If errors occur in feeding mode (e.g. no water) the concentrate mode will be sustained. The error messages can be checked in the key menu under 24 = Fault messages.

If errors occur in concentrate mode or on the scales, an error message appears:

error messages
see menu 24

The automatic calf feeder beeps at regular intervals. The error message disappears as soon as an animal is identified.

12.7.1 Connection errors

If the connection between the Stand Alone and the concentrate feeder is interrupted, an error message appears:

24# silo 1&2
connection interrup

- Check the connection cables to the concentrate feeders.
- Check the power supply of the concentrate feeders.

If the connection between the Stand Alone and the scales are interrupted, an error message appears:

24# scales at box
error: 11

At „11“ Connection Errors occurring on the scales, an alarm will be generated.

- Check connection cable to scales.
- Check power supply to cable.



At midnight calculation, the number of connection errors will automatically be reset to 0. Press key 0/C, to reset the connection errors to 0.

12.7.2 Check the calibration values for concentrate

If a calf enters a concentrate station where the concentrate has not been calibrated, and it is identified there, an error message will be displayed. The alarm LED at the concentrate dosing unit starts flashing.

error messages
see menu 24

In keyboard menu 10, 24 = fault messages, you are prompted to calibrate the concentrate of the relevant silos.

24# silo 2
please calibrate

The error message disappears after calibration.

12.7.3 Idle shaft

The dosing flap has to move approx. 5 – 6 seconds (= 5 rotations of the shaft) after the claim of a portion. If it does not move (e.g. after bridging of the foodstuff), dosing will be interrupted and the calf will not be quitted. After leaving the box, the dosing will be checked. If the dosing flap does not move, an alarm will be generated. The alarm LED on the concentrate feeder flashes, although the concentrate feeder does not yet switch off. With the next animal, another concentrate dispense will be tried.

The error message shows e.g., that in silo 1, two idle turns of the shaft have been detected.

```
24# silo1^14.11.97
idling shaft: 2
```

- Check the dosing flap.
- Change position of the adjustable plate with reed switch.
- Check the food for bridging.



Press key 0/C, to delete the message and actualise the date.

12.7.4 Shaft is blocked

When the shaft is blocked, an error message sounds:

```
24# silo 1^
shaft blocked
```

The concentrate feeder is out of operation and the alarm LED at the concentrate feeder flashes.

- Check whether foreign material is stuck in the shaft and remove it, if necessary.
- Motor sensor or gear motor are probably damaged. Contact the Service.

13 Additives

On switch position 9 = Additives, individual or entire groups can be rapidly and easily treated with powdery or liquid additives.



In this switch position, only activation of additive dispense can occur. The entries for the prescriptions or plans are made in the keyboard menus 14 or 12 and 13.

Dosing unit

Additives are dispensed by the dosing units.

To this end, dosing units are available for powdery additives (fine-dosing units for powdery additives) and for liquid additives (dosing pump).

With the Stand Alone both dosing units can be used simultaneously.

Calibration

Each additive must be calibrated. Refer to chapter 5.9.2, page 49, „Calibration, Calibration of Additives“.

Dispense

The additives can be dispensed according to plans or prescriptions. Dispense takes place either drink-dependent in grams per litre (g/l), weight-dependent in grams per 100 kg animal weight (g/100 kg) or as a daily quantity per animal and day (g/day).

For each way of dispense it can be decided, whether the additive will be dosed to milk or MP drinks or only to water (without milk).

As a principle, dispense takes place in two halves of the day from 00.00 to 12.00 h and from 12.00 to 24.00 h.

For the dispense g/100 kg and g/day the distribution of the quantity of additives can be set at a number of drink portions per day.



Examples of the distribution of the additive amount:

Distribution	Dosing of the additive takes place	Use
100 %	at each drinking portion	Distribution of additive evenly over the day
50 %	with the first 50 % of the drinking portions of the first half of the day and with the first 50 % of the drinking portions of the second half of the day	The additive should be dosed as a concentration during the first and second half of the day
30 %	Distribution see above	The additive should be dosed as a strong concentration during the first and second half of the day

Dosing without milk:

If the additive will only be dosed into water, the meal with additive consists of water and additive, subsequent meals of milk or MP drinking without additive.

Drink-dependent additive dispense:

The quantity of additive is identical for each portion, i.e. calves, getting much milk, get more additive than calves, getting less milk. Example: a 50 kg calf gets 8 l, a 100 kg calf 2 l

per day. If the quantity is 2 g/l, the 50 kg calf gets 16 g per day, the 100 kg calf however, 4 g per day.

Weight-dependent additive dispense:

The quantity of additive depends on the animal's weight, i.e. heavier calves get more additive than lighter calves.

This is based on the weight, which is indicated under switch position 6 = Animal data and Info in submenu Weight, Feeding days.

If no scales have been connected, the daily increase with the animal weight at the time of announcement will be entered. To take the accumulation of the increase into account, the entered daily increase will be daily raised by 2%.

If scales are connected, the weight and daily increase will be automatically determined.

Additive dispense in grams per day:

With the additive dispense in grams per day, the quantity of additive is neither coupled to the drinking quantity nor to the animal weight. The addition corresponds with the quantity per animal and per day.

Additive plans

There are plans possible for powdery and liquid additives. The additive plans can be optionally dispensed in g/l, in g/100 kg or in g/day. With the dispense g/100 kg and g/day the distribution of the additive quantity can be divided over several drinking portions per day.

The additive plans are, just like the drinking and concentration plans, coupled to the stabling date of an animal. The additive dispense starts at that point of the additive plan, that results from the drinking and correction days. After termination of a feeding plan, drinks will further be issued to the relevant animal for the duration of the additive dispense of drinking (with the value of the last daily quantity).

Prophylaxis:



As a prophylaxis the additive plans can automatically be dispensed for all calves after their registration. If this prophylaxis has been activated, principally each calf automatically gets in future after stabling the selected additive plan.



Should the additive plan be weight-dependent, the animal weight must be checked after stabling!

For treatments of diseases prescriptions are available.

Prescriptions

In case of prescriptions the additive will be dispensed according to the animal's weight (g/100 kg). The duration of the prescription is expressed in days. The dispense takes place animal-specifically or per group after activation of the prescriptions.

Five prescriptions for powdery and four prescriptions for liquid additives can be prepared beforehand. They can easily be called at any time. Each prescription is identified by a number.

Example for powdery additives (A/PoR1-5):

Prescription 1 A/PoR1 50 g/100 kg, 7 days long,

Prescription 2 A/PoR2 25 g/100 kg, 5 days long,

Prescription 3 A/PoR3 15 g/100 kg, 10 days long.

Example for liquid additives (A/Li.R6-9):

Prescription 6 A/Li.R6 20 g/100 kg, 8 days long

The prescriptions are entered in keyboard menu 14 = Entry of prescriptions. The prescriptions starts after activation under switch position 9 = Additives.



The portion of the additive quantity should, if possible, lie between 2 g/l and 20 g/l. Therefore, when distributing over the drinking portions per day the largest and smallest daily portions should be taken into account. If the portions are less than 2 g/l the additive can be added as glucose or milk powder, in order to get larger portions.

13.1 Entry of additive plans and prescriptions

13.1.1 A/Po-plan

Keyboard  Turn the program switch to 10 = keyboard.

 Enter 12 and confirm with ENTER.

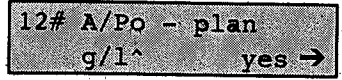

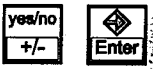

 Select the dispense method g/l, g/100 kg or g/day.

 Enter „yes“ and confirm with ENTER.

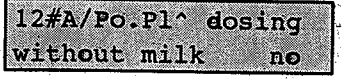
 Go to the next read-out.

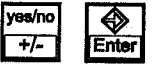

 Should the additive be dispensed without milk, i.e. only dosed into water, select „yes“ and confirm with ENTER. Should the additive be dosed into milk or MP drinks, select „no“.

 Go to the next read-out.

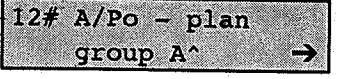

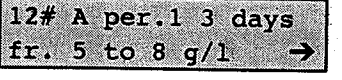

 Select group.

 Press ENTER. Enter the number of days for period 1.
Example:





 Confirm with ENTER. Enter the starting quantity in g/l.

 Confirm with ENTER. Enter the final quantity in g/l.

 Confirm with ENTER.

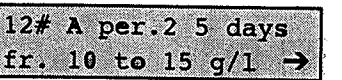
 Go to the next read-out. For the periods 2 to 5 proceed as for period 1. Example:



 After pressing ENTER, the end value of the preceding period will always be suggested as a starting value.

After the read-out of the period 5, the information about the duration of the A/Po plan and the feeding plan appears.
Example:

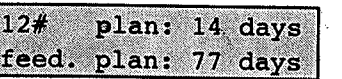



If the dispense g/100 kg or g/day has been selected, in the next read-out the percentage of division of the additive over the drinking portions of the first or the second half day can be entered.

```
12# A/Po - plan
in first 100 % →
```



Subsequently confirm with ENTER. Proceed as with the dispense method g/l.

13.1.2 A/Li-Plan

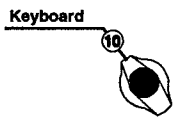

Turn the program switch to 10 = keyboard.

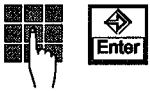

Enter 13 and confirm with ENTER.

```
13# A/Li - plan
g/l^ yes →
```



Select dispense method g/l, g/100 kg or g/day.

For further entries, proceed as described in the A/Po plan.

13.1.3 Prescriptions

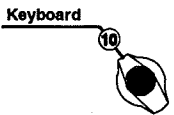

Turn the program switch to 10 = keyboard.



Enter 14 and confirm with ENTER.

```
14#prescr. for100kg→
bodyw./day A/Po ^
```



Select A/Po or A/Li for powdery or liquid additives.



Go to the next read-out.

```
14# A/Po.R1^ 1days
0 g in first 100 %
```



Select prescription (A/Po 1-5, A/Li 6-9).



Press ENTER. Enter the duration of the prescription.



Confirm with ENTER.

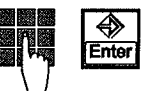

Enter the additive quantity per 100 kg animal weight and confirm with ENTER.



Press ENTER. Here, the division as a percentage of the drinking portions of the first or second half of the day can be entered.



Confirm with ENTER.



Go to the next read-out.

14#A/Po.RI^ dosing
without milk no

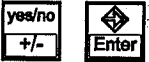

If the additive should be dosed without milk, i.e. only into water, enter „yes“ and confirm with ENTER. If the additive should be dosed into milk, enter „no“.

13.2 Activation of the additive dispense

If an animal or an entire group should get an additive, the dispense of the additive will be activated under switch position 9 = Additives, after the prescriptions or the plans have been previously specified in the keyboard menu and have been added.

The following submenus are possible:

- A/Po individual
- A/Po group
- A/Li individual
- A/Li group
- Block the remaining portion
- Prophylaxis
- Info

13.2.1 A/Po individual

Keyboard



Turn the program switch to 9 = Additives.

```
additives →
A/Po  individual^
```



Go to the next read-out. The available prescriptions with the duration of the dispense and the dosing or additive plan appear.

```
A/Po.R1^ →
8 days 25 g/100 kg
```



Select prescription or plan.

An asterisk * following the prescription number means that this prescription is now active or was the last being active.

If the selected prescription is followed by „Without Milk“, the additive will then only be dosed into water. Without comment the additive will be dosed into milk or MP drinks.



Go to the next read-out.

```
2D^A/Po.R1 →
apply      no
```



Select animal number and confirm with ENTER.



Select „yes“ and confirm with ENTER. Check the actual weight and increase and correct if necessary.

```
2D^ weight 63 kg →
LWG      + 480 g/day
```



At the warning „Check calibration“, check or calibrate the additive (switch position 5 = Calibration).



It is possible to change a prescription or to activate an available prescription.



Change prescription: Select prescription or plan, e.g. A/Po.R3.

```
A/Po.R3^ →
5 days 30 g/100 kg
```



Go to the next read-out. A warning appears, as due to the change, the treatment of all active animals will be cancelled.

```
2D^A/Po.R1 →
adjust treatment
```



Go to the next read-out.

```
change additives →
A/Po.R1 delete ? no
```



Select „yes“ and confirm with ENTER.

```
2D^A/Po.R2
apply no
```

13.2.2 A/Po group



Go to submenu A/Po group.

```
additives →
A/Po group ^
```



Go to the next read-out.

```
A/Po.R1^ →
8 days 25 g/100 kg
```



Select prescription or plan.



Go to the next read-out.

```
group A^ A/Po.R1 →
apply no
```



Select group.



Select „yes“ and confirm with ENTER.



A notice appears „Check Animal Weight“. Check animal weight and actual daily increase (switch position 6 = animal data and info, submenu weight, feeding days) for all activated animals.

If in the selected group some animals already get an additive after activation of individual animal, the following warning appears:

```
in group A^
is already applied
```



Attention: Animals which at present are already treated, are again placed at the beginning of an additive plan!

If in the selected group no animals have been registered, no warning will appear:

```
in group B^
no animalregistered
```

13.2.3 A/Li individual



Select submenu A/Li individual.

```
additives      →
A/Li  individual ^
```



Go to the next read-out.

```
A/Li. R6^      →
7 days  15 g/100 kg
```



Select prescription 6 - 9 or plan. An asterisk * following the prescription number means that this prescription has just been activated or was the last being activated. On the second line the duration of the prescription and the quantity per 100 kg animal weight appears, but only as information.



Go to the next read-out.

```
2D^ A/Li.R6    →
apply   no
```



Select the animal number.

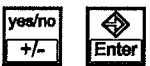

Select „yes“ and confirm with ENTER.

For warnings and prescription change: refer to „A/Po individual“.

13.2.4 A/Li group



Select submenu A/Li group.

```
additives      →
A/Li  group    ^
```



Go to the next read-out.

```
A/Li. R6^      →
7 days  15 g/100 kg
```



Select prescription 6 - 9 or plan. An asterisk * following the prescription number means that this prescription has just been activated or was the last being activated. On the second line the duration of the prescription and the quantity per 100 kg animal weight appears, but only as information.



Go to the next read-out.

```
2D^ A/Li.R6    →
apply   no
```



Select animal number.



Select „yes“ and confirm with ENTER.

For warnings and prescription change: refer to „A/Po Group“.

13.2.5 Block on remaining portion

If a calf, getting its additive, does not empty its mixer jar, a rest remains with an additive. If individual animals (e.g. veal calves) are not allowed to receive even a small quantity of additive, access to this rest portion can be blocked for these animals. A condition is of course the presence of a valve control, which can block and release the suction lines. For blocked animals the suction line is only then opened, if the sensor is free or if the mixer jar contains drinking without additive.



Go to submenu „Block on Remaining Portion“.

```
additives →
block remain.port. ^
```



Go to the next read-out.

```
12A^ remain.port. →
block with A ? no
```



Select animal number.

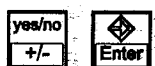

Select „yes“ and confirm with ENTER.



If too many animals are blocked, feeding can temporarily be interrupted for a longer period.

13.2.6 Prophylaxis

In this submenu the additive plan can be automatically activated after registration for powdery or liquid additives as a prophylaxis for all calves. If this prophylaxis has been activated, principally each calf automatically gets in future after stabling the selected additive plan.



Go to submenu prophylaxis.

```
additives →
prophylaxis ^
```



Go to the next read-out.

```
A/Po.Pl.^ start
with register no
```



Select A/Po.Pl or A/Li.Pl.

```
A/Po.Pl.^ start
with register no
```



Select „yes“ and confirm with ENTER, the prophylaxis must be active.

```
A/Po.Pl.^ start
with register yes
```



After stabling, each calf automatically gets additive according to the selected additive plan, until „no“ is entered again.

If the additive plan is weight-dependent, check animal weight after stabling!

13.2.7 Info

In this submenu only animals getting additive will be displayed.



Go to submenu Info.

```
additives →
Info      ^
```



Go to the next read-out. On the first line appears which A/Po prescription has been activated. The second line contains information about the dispense period of the prescriptions and how long from now on the relevant animal will get additive.

```
12A^ A/Po.R1 →
8 days, rest 2 dy
```

If for neither animal a powdery additive has been activated, the following message appears:

```
A/Po... →
no application
```

If for the selected animal no powdery additive has been activated, the following message appears:

```
2D^A/Po... →
no application
```



Go to the next read-out. Here, the daily quantity of powdery additive for the selected animal appears and how much already has been dispensed.

```
12A^ A/Po.R1 20 g →
consumed      10 g
```



Go to the next read-out. Here, yesterday's quantity setting of powdery additive and yesterday's actually dispensed quantity.

```
12A^ A/Po.R1 18 g →
yesterday    18 g
```



Go to the next read-out. Here, the breaks with additive for today and yesterday appear.

```
12A^breaks,w.add. →
today 0 yest. 0
```



Go to the next read-out for the liquid additives.

```
12A^ A/Li.R6 10 g →
consumed      5 g
```

After the read-out for powdery additive, the same image appears for the liquid additives. The images for the liquid additives are similar to those for powdery additives.

14 Animal scales

Connection see Connection Plan



Make sure that scales 1 is connected to feeding station 1 and scales 2 to feeding station 2. On the motherboard, scales 1 represent Channel 4 and scales 2 Channel 5.

In switch position 10 = keyboard menu, after entering 25 you may check the animal scales connected. The display shows the animal weight that has just been ascertained. In this menu you can also tare the animal scales. In menu „Animal Scales“ you may tare the animal scales and carry out weighing. Whereas in menu „Connections“ you may check whether communication has been established to the animal scales connected.

14.1 Checking connection, taring animal scales, carrying out weighing

Keyboard



Turn the program switch to 10 = keyboard.



Enter 25. Confirm with ENTER. The automatic feeder checks automatically whether communication has been established to the animal scales.

```
25# test   box:2
please wait..... →
```

The display shows:

```
25# test   box: 2^
connection start →
```



By means of Arrow Up or Arrow Down, select the box to which you want to check communication.



Press Start/Stop to start the connection test.

In case there is no connection to the animal scales, the display shows the following error message:

```
anim.scales 1&2
connection error!
```

In case the connection is o.k., the display shows the following message:

```
anim.scales 1&2
connection ok!
```



After „11“ connection errors to the animal scales, an alarm will be triggered and the animal scales will be deactivated.



Move to the next read-out with Arrow Right.

```
25#HS1 at   box:2 →
tare                start
```



Press Start/Stop to tare the scales.

```
25#HS1 at   box:1
tare.....
```

After tare has been carried out the display shows:

```
25#HS1 at box:2 →
tare finished
```



The scales will be tared automatically every 15 minutes when no animal is identified or in case less than 10 kg weight are on the scales.



Move to the next read-out with Arrow Right.

```
25#HS1 at box:2 →
scales start
```



Put a weight on the scales (in case of 50 kg, two sacks of milk powder) and start weighing.

```
HS1 at box:2
weigh.....
```

The display indicates the weight of the two sacks of milk powder that has been determined (this value cannot be altered manually).

```
HS1 at box:2
W at HS = 55,5 kg
```



15 Accessories

15.1 Two-group valve unit

The Stand Alone - Automatic Calf Feeder can subsequently operate two feeding stations by a priority control with the two-group valve. Priority control means that a calf with drinking right, at entering the feeding station can take its ration without interruption, while the other station is blocked for this period. Change-over takes place by means of the two-group valve unit.

The milk hose runs from the mixer to the hose connection between both solenoid valves. The connections from the solenoid valve to the teat are located at the bottom of the relevant solenoid valves.

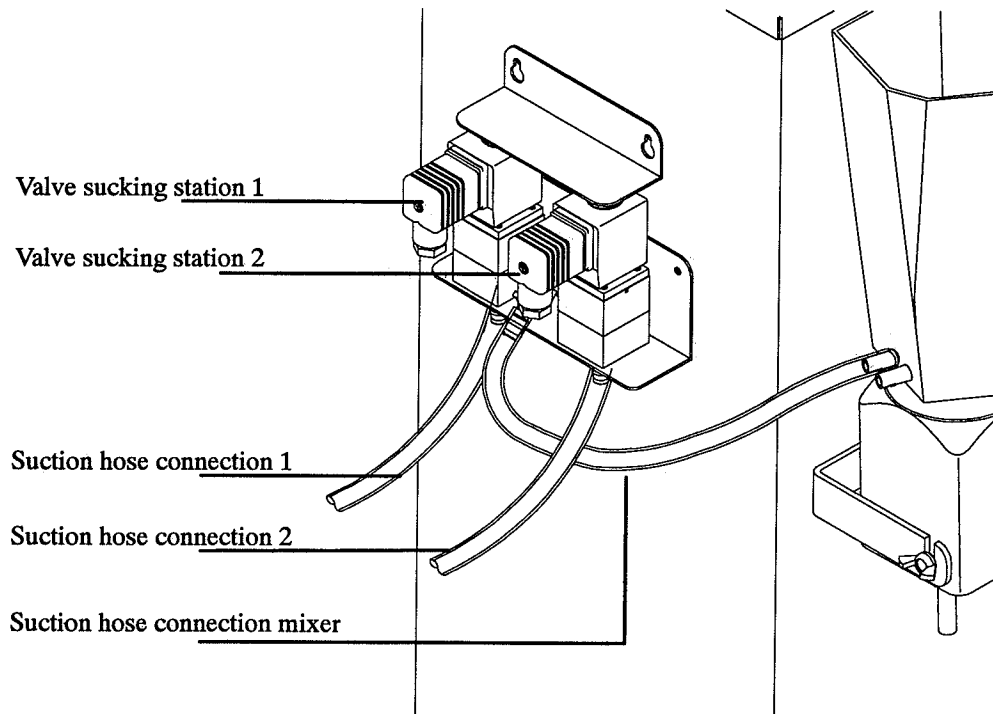
Both illuminated plugs of the solenoid valves show which suction lines (1 or 2) are open.



Take care that suction hose connection 1 runs to sucking station 1 (antenna 1), suction hose connection 2 runs to sucking station 2 (antenna 2). If the sequence is neglected, a calf, trying to get its portion on sucking station 1, gets no drinks and its portion will be given out on sucking station 2 instead.

15.2 Additive dispenser

To a Stand Alone up to two additive dispensers can be connected (one additive dispenser for powdery and one for liquid additives). The cable for one additive dispenser is factory-set located in the automatic calf feeder and provided with a plug.

Connection: To connect the additive dispenser remove the powder hopper unit and pass the cable through one of the openings on the left-hand side of the body shell to the outside.

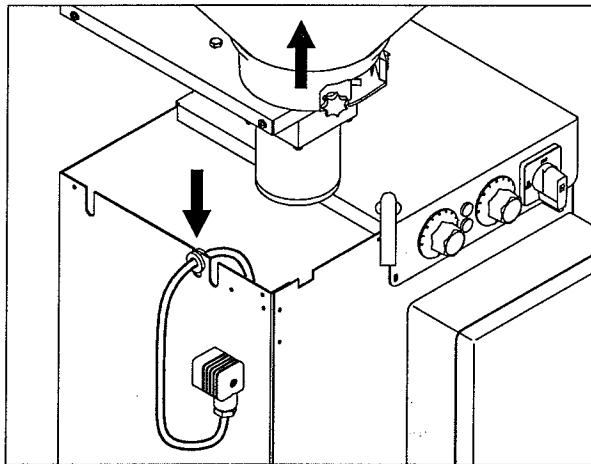

Mounting: For mounting and starting of the additive dispensers, refer to the user manual „Fine-dosing units for powdery additives“ or „Dosing pump“.

15.3 Pilot lamp box for Stand Alone automatic calf feeder

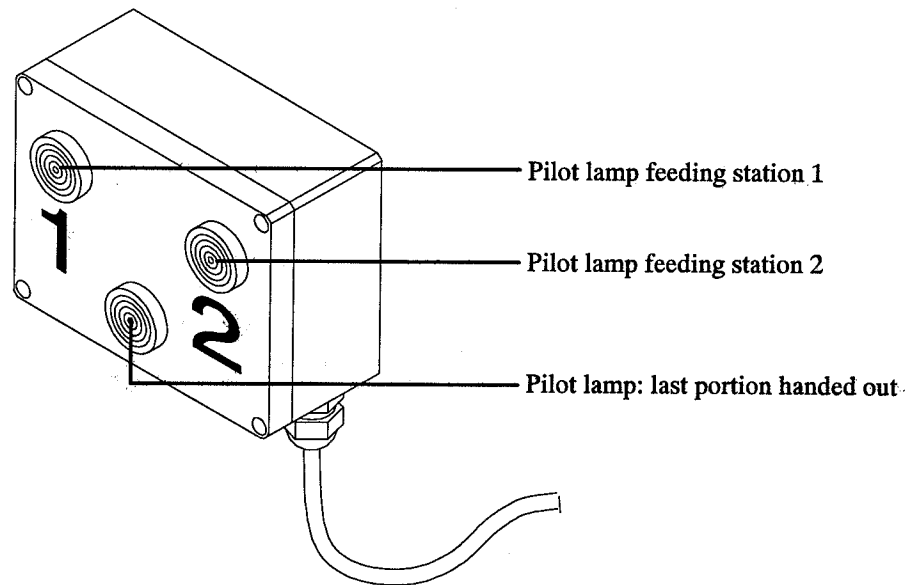

The pilot lamp box in the stable indicates whether a calf in the drinking station has an allotment and whether for this calf the last portion has been dispensed.

To this end, the pilot lamp box has a pilot lamp for each feeding station as well as a pilot lamp for the issue of the last portion.

Pilot lamp 1 or 2 indicates in which station drinks have been issued, the third pilot lamp lights, when the last portion of the calf in the relevant station has been issued. In this way you can see in time, when the next calf should be brought to the feeding station for teaching-in. If there is no visual contact between the two bays, an additional pilot lamp box can be connected. To this end the lamp box has twin-terminals.

Remote alarm: Only present as an option on an automatic calf feeder with a 2-group priority control. If the remote alarm will only be necessary for general operational errors, it requires a specific pilot lamp box which enables connection of a remote alarm (230 V, 25 W). For connection, refer to wiring diagram.

A

- accessories, 11, 141
- accustoming aid, 66
- activating hose pipe cleaning, in Setup, 44, 46
- activation of additive dispense, 134
- activation of cleaning system, in Setup, 43, 44
- actual warning, drinking, 102
- ad libitum
 - concentrate, 90
 - distribution of drinking, 90
- additive dispense
 - drink--dependent, 128
 - weight--dependent, 129
- additive dispenser, 142
- additive plans, 131
- additive warning, 104
- animal data, 108
 - cancellation, 111
 - change of registration, 112
 - daily ration / animal, 110
 - daily ration/animal, 108
 - entry of Responders, 108
 - registration of animals, 57
 - weight, feeding days, 108
- animal identification, 54
- animal scales, 139
- animal scales, selecting in Setup, 39
- antenna test, 55
- antenna--Squelch, 20, 37, 56
- automatic mixer cleaning, 116
- automatic registration, 60

B

- basic settings at starting, 34
- block on remaining portion, 137
- boiler, 11
 - contents, 15
 - fill with water, 26
- box selection, accustoming aid, 66
- breaks, 103

C

- calibration
 - additives, 49
 - concentrate, 51
 - MP, 48
 - water, 48
- calves with right, 97
- cancellation of individual animals, 111
- carry out new installation, 34
- carry over, 78, 89
- carrying out check routine, 119
- change registration of animals, 112
- check, date/time, 34
- check functions, 96
- check powder outlet, 119
- check the dosing flap, 24
- claim
 - concentrate, 99
 - drinking, 98
- clean alert, 124
- cleaning, 115
- cleaning agent, 117
- concentrate feeder, 13
- concentrate intervals, 76
- concentrate station, connection test, 47
- concentrate storage tank, storage capacity, 16
- concentrate--dependent feeding, 70
- connecting additive dispenser, 142
- connecting the mains plug, 26
- Connection, suction hose, 18
- connection
 - animal scales, 139
 - electrical, 15
 - micro--identification, 20
 - two--group valve unit, 141
 - water, 22
- connection errors at scales connection, 126
- connection of, additive dispenser, 142
- connection test of concentrate station, 47
- connection test, animal scales, 139
- construction parts
 - concentrate feeder, 13, 14
 - control power supply unit Powder, 10
 - Stand Alone Powder, 9
- consumption, 113

consumption totals, 114
control, Master, Slave, 14

D

daily calculation, 95
daily ration/animal, 110
date / time
 check, 34
 enter, 34
dates of expiry, 106
day warnings
 concentrate, 105
 drinking, 102
delete
 demand, 93
 feed delay, 93
delete demand, 93
 for one animal, 94
 for the entire group, 94
delete warnings, 102
deviations
 of concentrate, 63
 of concentration, 63
 of drinking portions, 62
 of liquid additives, 65
 of powdery additive, 64
Dip switch, 38
distance concentrate feeder, Stand Alone, 16
distribution of concentrate
 ad libitum, 90
 restricted, 90
distribution pause, setting, 42
dosing quantity, concentrate, 99
draining time, 41, 42
drinking
 addition, 62
 preparation, 89
 reduction, 62
drinking distribution, 89
drinking right, 98

E

earth leak switch, 17
electrical connection, local, 17

enter, date/time, 34
enter concentrate plan, 73
ENTER key, 32
entering, correction days, 61
entering concentration plan, 72
entering routine, 32
entitlement intervals, 75
 concentrate, 76
equipment data, 85
equipotential bonding, 17
error messages
 check calibration values, 123
 clean alert, 124
 data destroyed, 123
 error in concentrate mode, 126
 feeding interrupted, 123
 idle shaft, 127
 mains interruption, 125
 restoring from backup, 125
 shaft is blocked, 127
 water check, 125
 water shortage, 124
ESCAPE key, 32
expired animals, 106
extra portion, release, 91

F

feed delay, delete, 93
feeding behaviour, 98
feeding box, 19
feeding intervals, 75
feeding plans, 68
feeding pump, hand-actuated, 12
feeding speed, 103
frost danger, 120
function table, 32
functioning, automatic calf feeder, 88

I

idle shaft, 127
info, for additive dispense, 138
installation, automatic calf feeder, 17, 26
institute program, 40

interface test, 41

intervals

- concentrate, 76
- feeding, 75

K

keyboard menu, keyboard, 28

keys

- arrow keys, 30
- hand--operation keys, 31
- toggle keys, 30
- with a double function, 29

L

level sensor, 89

lightning protection, 17

list printing

- verification list, 122
- warning list, 122

location, concentrate feeder, 23

long sensor covered, 92

long sensor free, 91

M

mains interruption, 125

maintenance, 118, 121

maximum quantity, 77, 78, 79, 89

micro- -identification

- connection to Stand Alone, 55
- Mikro--Nedap, 20
- Mikro--Tiris, 20

milk powder, fill into the powder hopper, 26

milk powder hopper, storage capacity, 15

minimum saved quantity, 77, 78, 79, 88

mixer, Setup, 43, 44

mixer cleaning, 115

- automatically, 117

mode

- ad libitum, 86
- restricted, 86

Mounting of

- the sucking station, 18

the suction bracket, 18

the top section on MP powder hopper, 21

mounting of

- the additive dispenser, 142
- the concentrate feeder, 23

mounting the race--way, 19

N

new installation, 34

nominal frequency, 17

nominal voltage, 17

number of animals per concentrate feeder, 16

number of calves, 15

O

operating and control unit, 27

operating unit, 27

operation, concentrate feeder, 88

operational controls, 27

- processor, 28

operational data

- age--dependent drinking, 68
- concentrate plans, 73
- concentrate--dependent feeding, 70
- concentration plans, 72
- feeding plans, 68

P

pilot lamp box, 143

power supply unit, 10, 27

preparation, of drinking portions, 89

prescriptions, 129, 131, 132

pressure reducer, 22

printer connection, also refer to the appendix, 122

printing

- Setup, 38
- verification list, 122
- warning list, 122

priority control, 141

program switch, 28

prophylaxis, 129, 137

Q

quadruple priority control, 41

quantity limits
concentrate, 80
drinking, 77, 78

R

race-way, 19
reach of the antennas, 56
overlapping, 55
reading the Responder numbers, 55
registering feeding boxes, in Setup, 41
registration
automatically, 60
in groups, 59
individual animals, 57
regulating the dosing flap, 25
remote alarm, 143
RESET key, 14, 87
Responder
ear tag Responder, 56
ear tag-Responder, 37
X-Responder, 37, 56
Responder numbers, entering, 54
automatically, 55
manually, 56
restricted
concentrate, 90
distribution of drinking, 89
retractable teat, 43, 46
robbers, 104

S

safety instructions, 8
scales, 139
selecting the animal scales, in Setup, 39
sensor
long, 89
position, 118
shaft, 118
short, 89
service, 118, 121
setting the baud rate, 37
setting the heating
avoiding measuring errors, 53
minimum operating temperature, 52
setting the thermostats, 52

temperature measurement, 53
temperature settings, 53

Setup, 36

activating concentrate, 36
activating hose pipe cleaning, 44, 46
feeding boxes, 41
selecting the animal scales, 39
selecting the printing function, 38
selecting the retractable teat, 43, 46
setting the baud rate, 37
test interface, 41

shutdown, 120, 121

specifications, calf feeder, concentrate feeder, 16

Squelch, 20, 37, 56

stabling date, 58

station number, 85

Suction hose, 18

surge voltage protector, 17

switching on the main switch, 26

symbols, graphic, 7

system data, 34

T

teat, retractable, 43, 46

technical data, automatic calf feeder, 15

Top section, milk powder hopper, 21

two-group valve unit, 141

U

unknown Responders, 104

unstabling of animals, 111

V

verification

animal scales, 100
animal verification C1, 99
animal verification C2, 100
C1 and C2, 99
calves with right, 97
feeding behaviour, 98
number of animals, 101
visit and robbery, 100

verification list, printing, 122

visit and robbery, 100

W

- warning levels, 82
 - concentrate, 83
 - feeding, 82
- warning list printing, 122
- warning today, concentrate, 105
- warnings, 102
 - concentrate, 105
 - drinking, 102
- water connection, 15, 22
- water heating, in boiler, 11
- water pressure, 22
- water shortage, 124
- weight, 108

Declaration of Conformity

Förster Technik GmbH
 Gerwigstr. 25
 D-78234 Engen
 Tel.: 07733/9406-0
 Fax: 07733/9406-99



Declaration of Conformity According to Council Directive 89/392/EEC, appendix II A, 89/336/EEC, 73/23/EEC and 93/68/EEC on the Approximation of Laws of the EEC Member States Relating to Machinery

By this we declare under our sole responsibility that the following calf feeder:



TAK*-SA1-32-M	TAP*-SA1-32-M	TAK*-SA2-27-F	TAP*-SA2-27-F
TAK*-SA1-38-M	TAP*-SA1-38-M	TAK*-SA2-28-P	TAP*-SA2-28-P
TAK*-SA1-50-M	TAP*-SA1-50-M	TAK*-SA2-30-P	TAP*-SA2-30-P
TAK*-SA1-75-M	TAP*-SA1-75-M	TAK*-SA2-32-P	TAP*-SA2-32-P
		TAK*-SA2-38-P	TAP*-SA2-38-P
			TAP*-SA2-50-P
			TAP*-SA2-75-P

with all accessories, * according to box size 0, 1 or 2

correspond equally to the following relevant norms:

EN 292-1 / 11.91	Basic concepts of general design of machines, part 1
EN 292-2 / 06.95	Basic concepts of general design of machines, part 2
EN 294 / 8.92	Safety clearance for upper limbs
EN 349 / 6.93	Minimum clearance for avoiding crushing upper limbs
EN 50081-1 / 3.93	Norm concerning electromagnetic emissions on residential areas, business districts and industrial areas
EN 50082-1 / 11.97	Norm of the resistance to jamming against line directed disturbances, induced by highfrequency fields above 9 kHz
EN 563 / 08.94, 01.95	Temperatures of touchable surfaces
prEN 1070 / 6.93	Safety of machines, terminology
EN 60204-1 / 6.93	Electrical components of machines

Date: September, 1999

 Wolfgang Latz	 Alfred Steiner
--	--

Signatory: M. Latz, Head of Production Management
 M. Steiner, Head of Production, Department Electrical Components

Connection between Printer and Stand Alone



September 1999

Printer connected to Stand Alone

A printer can be connected to the Calf feeder „Stand Alone“. There are different print-outs possible (alarm-list, control list), either by hand or automatically after the midnight-calculation.

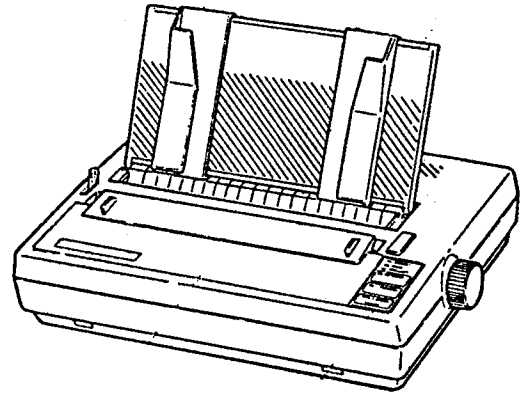

The printer has to be equipped with a

serial interface port RS 232

with the following configuration:

**1200 baud rate
8 data bit
1 stopbit
without parity
standard ASCII-character table
and standard IBM character table**

The configuration can be set by DIP-switches or by software. For further information take your instruction manual for the printer.

Förster-Technik GmbH • Gerwigstr. 25 • 78234 Engen • Tel.: 07733/9406-0 • Fax: 07733/940699

Feeding plan group A

Stand Alone SA 2
Feeding Plan Group A
Förster-Technik

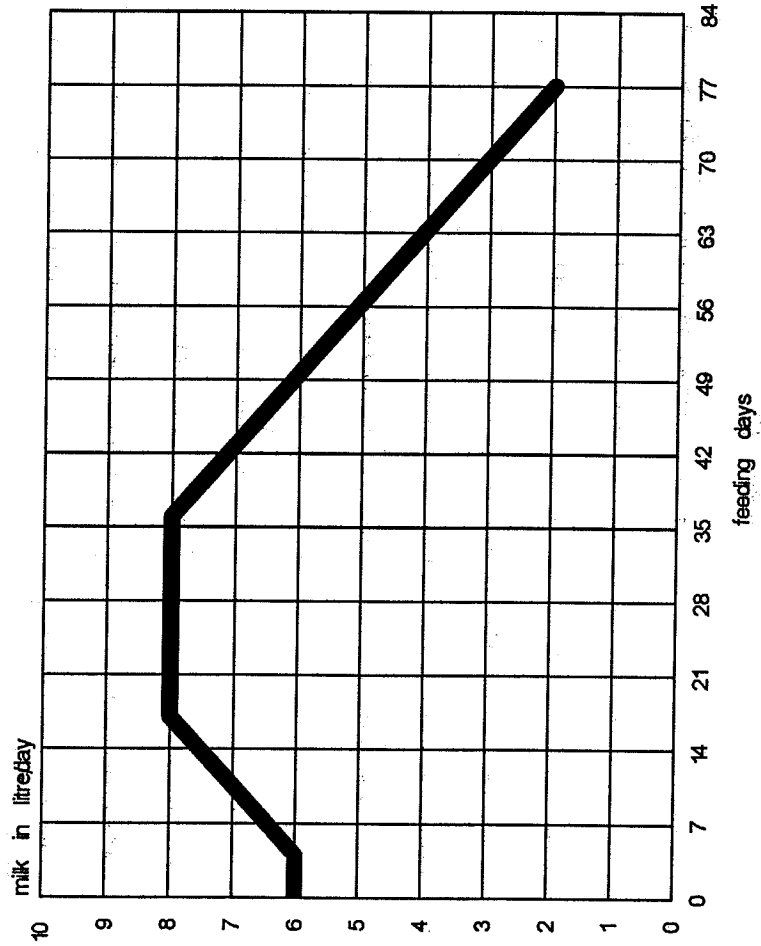

Feeding plan (standard values):	
3 days: from 6 to 6 l	
14 days: from 6 to 8 l	
18 days: from 8 to 8 l	
42 days: from 8 to 2 l	
Total: 77 days = 468 l	
Concentration plan (standard values):	
10 days: from 90 to 120 g/l	
67 days: from 120 to 120 g/l	
Total: 77 days = 55 kg MP	
Feeding limits (standard values):	
14 days: 1,5 l (Min)	2,0 l (Max)
14 days: 2,0 l	2,5 l
49 days: 2,5 l	3,0 l

e-SA2-TP.PRS
07.04.98

Feeding plan group B

Stand Alone SA 2
Feeding Plan Group B
Förster-Technik

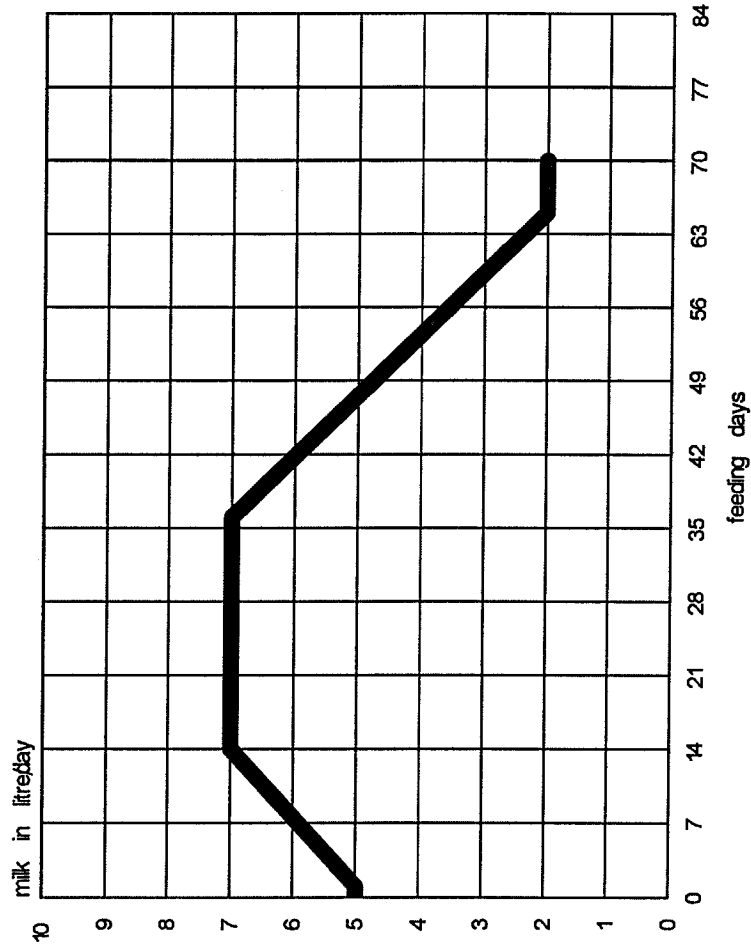

Feeding plan (standard values):	
14 days: from 5 to 7 l	
21 days: from 7 to 7 l	
30 days: from 7 to 2 l	
5 days: from 2 to 2 l	
Total 70 days = 374 l	
Concentration plan (standard values):	
10 days: from 90 to 110 g/l	
60 days: from 110 to 110 g/l	
Total 70 days = 41 kg MP	
Feeding limits (standard values):	
14 days: 1,5 l (Min)	2,0 l (Max)
14 days: 2,0 l	2,5 l
49 days: 2,5 l	3,0 l

e-SA2-TP_PRS
07.04.98

Feeding plan group C

Stand Alone SA 2
Feeding Plan Group C
Förster-Technik

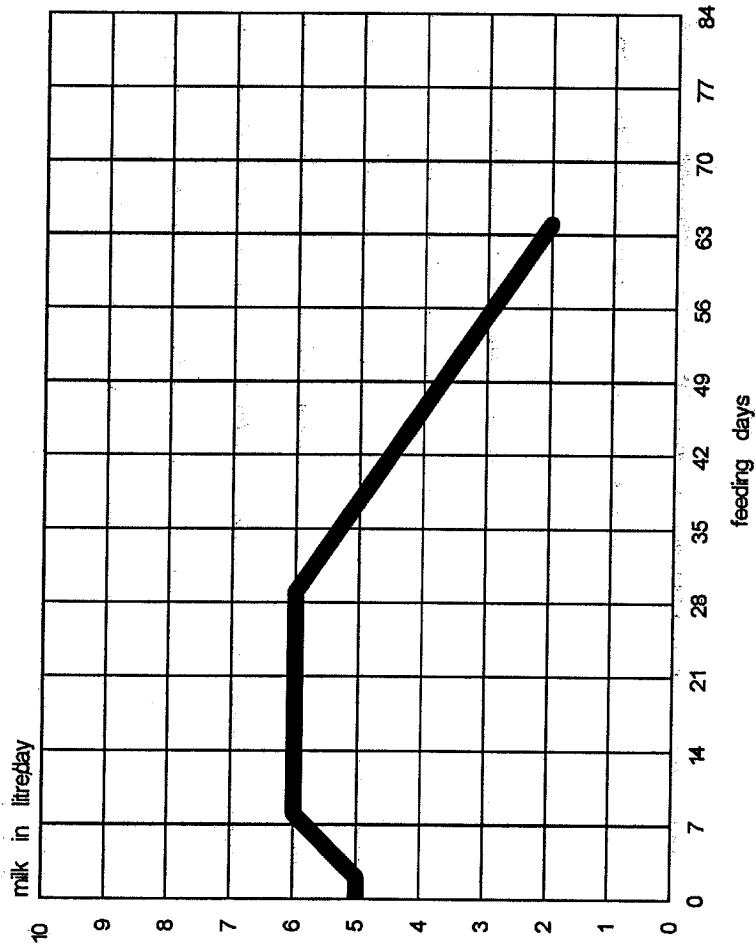

Feeding plan (standard values):	
2 days: from 5 to 5 l	
6 days: from 5 to 6 l	
21 days: from 6 to 6 l	
35 days: from 6 to 2 l	
Total: 64 days = 307 l	
Concentration plan (standard values):	
10 days: from 90 to 100 g/l	
54 days: from 100 to 100 g/l	
Total: 64 days = 30 kg MP	
Feeding limits (standard values):	
14 days: 1,5 l (Min)	2,0 l (Max)
14 days: 2,0 l	2,5 l
49 days: 2,5 l	3,0 l

e-SA2-TP.PRS
07.04.98

Feeding plan group D

Stand Alone SA 2
 Feeding Plan Group D (for very young calves)
 Förster-Technik

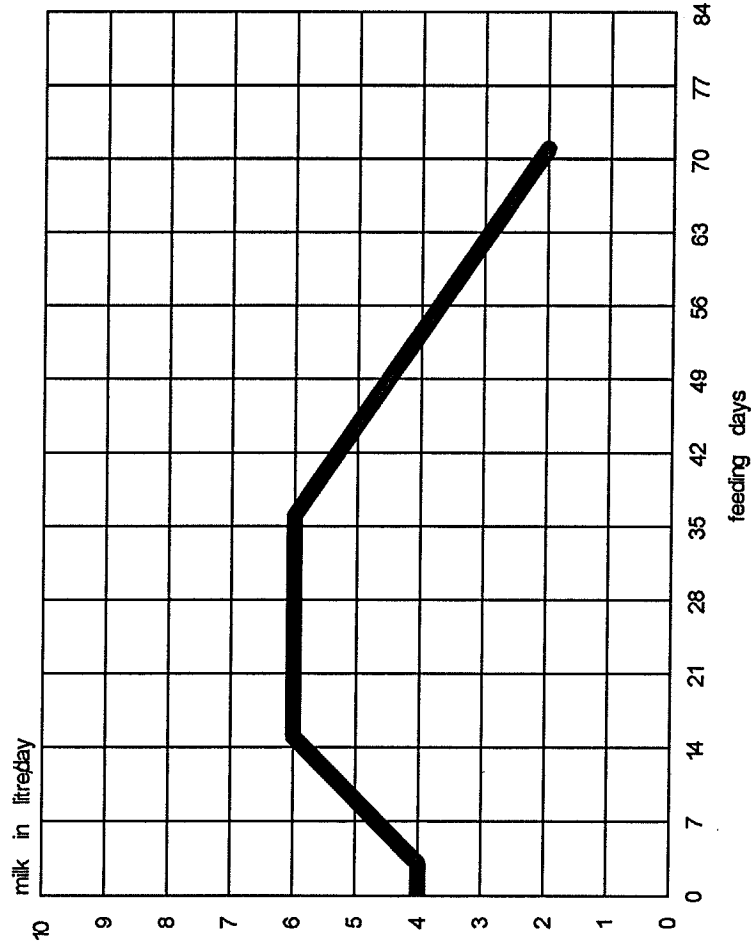

Feeding plan (standard values):	
2 days: from 4 to 4 l	
13 days: from 4 to 6 l	
21 days: from 6 to 6 l	
35 days: from 6 to 2 l	
Total 71 days = 338 l	
Concentration plan (standard values):	
71 days: from 120 to 120 g/l	
Total 71 days = 41 kg MP	
Feeding limits (standard values):	
7 days: 1,0 l (Min)	1,5 l (Max)
14 days: 1,5 l	2,0 l
14 days: 2,0 l	2,5 l
36 days: 2,5 l	3,0 l

e-SA2-TP PRS
 07.04.98

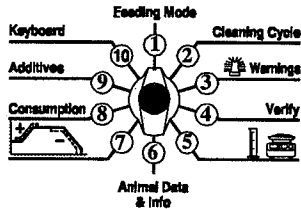

Function Table Program Menu Switch Stand Alone 2 Powder with Concentrate

1 Feeding	Extra-portion: If mixer jar is empty, press „Start“. Enter concentration, dosing quantity and distribution via feeding station or in container (e. g. bucket). Press „Start“ again.				
2 Cleaning	Cleaning Mixer →	duration			
3 Warnings (Warning- and expired animals)	Number of Mess. \wedge v →	warning animals feeding →	warning animals concentrate/weight →	expiry plan animals	Delete warnings with 0/C key
	Warn. Anim. Feed. \wedge v →	Concentrate Warnings			
	Warning Anim. C. \wedge v →	• Warning today and day warning are calculated regarding to the feeding plan			
	Warn. Anim. weight \wedge v →	• 3-days warning is calculated regarding to average consumption of the last 3 days			
	Expiry Plan Anim. \wedge v →				
4 Verify	Calves with Right \wedge v →	number →	available drinking No. of feeding station/consumption		
	Feeding Behaviour \wedge v →	available drinking No. station/consumpt. →	consumpt.yesterd. No. station/consumpt. →	breaks without additive →	breaks with additive
		drink.speed today →	drinking speed yesterday		
	Anim. Verific. C1/2 \wedge v →	available/consumpt. →	consumption yesterday		
	Anim. Verific. C1 \wedge v →	available/consumpt. →	consumpt. yesterd. →	C1 of 3-days \emptyset →	dosing amount
	Anim. Verific. C2 \wedge v →	available/consumpt. →	consumpt. yesterd. →	C2 of 3-days \emptyset →	dosing amount
	Visit & Robbery \wedge v →	total robberies →	visits fed →	visits not fed →	visits with/without C.
	Animal Scales \wedge v →	examine animal weight in list →	visit today →	day weight	
Number of Animals \wedge v →	registered/available →	registered in group			
5 Calibration	Water \wedge v →	Calibration process			
	MP \wedge v →	1. Press „Start“ to get calibration quantity			
	Concentrate \wedge v →	2. Measure resp. weigh the calibration quantity			
	Additive Powder \wedge v →	3. Check whether calibration quantity is equal to target quantity. If not, enter the amount dispensed and repeat calibration process.			
	Additive Liquid \wedge v →				
6 Animal Data	Weight/Days Fed \wedge v →	weight/LWG →	days fed/ registration date →	correction days →	expiry of C1/C2-plan
	Daily Ration/Animal \wedge v →	feeding concentrate →	feeding concentration →	MP →	A/Po → C1 A/Li → C2
	Cancel Registration \wedge v →	cancel individual animal →	cancel all animals via feeding plan →	cancel all animals	
	Register \wedge v →	available number →	register	Identification Numbers	
	Register Groups \wedge v →	animal 1-999 in group		1:- Without Responder Number	
	Register Automat. \wedge v →	autom. registration →	group, weight, LWG	1a: Responder Number available (with Responder-No.)	
	Change registration \wedge v →	change group		Animal No. 1 registered in group A,B,C,D	
	Responder Input \wedge v →	animal No./ Resp. No. →	antenna test →	antenna Squelch	
7 Deviations	Feeding \wedge v →	duration and quantity			
	Concentration \wedge v →	duration and quantity			
	Concentrate \wedge v →	C1 duration and quantity →	C2 duration and quantity		
	Additive Powder \wedge v →	duration and quantity			
	Additive Liquid \wedge v →	duration and quantity			
8 Consumpt.	MP Requirement Consumption →	A/Po. requirement consumption →	A/Li. requirement consumption →	C1/C2 requirement consumption	
9 Additives	A/Po. Individual \wedge v →	A/Po. according to prescription / plan →	apply		
	A/Po. Group \wedge v →	A/Po. according to prescription / plan →	apply		
	A/Li. Individual \wedge v →	A/Li. according to prescription / plan →	apply		
	A/Li. Group \wedge v →	A/Li. according to prescription / plan →	apply		
	Block Rem. Portion \wedge v →	block remaining portion ?			
	Prophylaxis \wedge v →	start at registration ?			
	Info \wedge v →	A/Po., A/Li., remaining days	consumption today →	consumpt.yesterday →	break with additive

Function Table, Keyboard Menu „10“

Operational Functions

1	Machine Data	Date, Time →	station No. prg.-vers.	prg. vers.concentr. →	operating days	
2	Restricted/Ad lib	Restricted/ad lib →	cons.today/yester. →	concentration →	A/Powder, A/Liquid, g/l	
4	Accustoming Aid	Box selection ^ v →	box accustoming →	warning animals / box ^	priority	
5	Setup	Concentrate ^ v →	register silo ^ v →	silo 1-4 ^ v C1/2 →	dosing code →	antenna squelch
		Set baud rate ^ v →	baud rate 19200 ^ v			
		Printing ^ v →	auto printing →	printer channel ^ v		
		Animal scales ^ v →	register animal scales box 1/2 →	parameter animal scales →		
			weight factor →	tare animal scales →	institute program	
		Interface test ^ v →	test channel 1 - 5			
		Feeding Boxes ^ v →	register/cancel feeding box →	draining time		
		Distribution pause ^ v →	distribution pause in seconds			
		Mixer ^ v →	automatic cleaning →	frequency of cleaning		
Retractable teat ^ v →	retractable teat available ? →	retraction time teat				
Hose cleaning ^ v →	group ^ v →	as of age (in weeks)				

Nutritional Plans

10	Feeding Plan	Group ^ v →	period 1 - 5 →	duration plan →	plan requirement	
11	Concentration Plan	Group ^ v →	period 1 - 5 →	durat. conc.-plan → durat. feeding plan	plan requirement	
12	A/Po-Plan	g/l,g/100 kg/day →	dose without milk? →	group ^ v →	period 1-5 →	durat. A/Po./feeding plan
13	A/Li-Plan	g/l,g/100 kg/day →	dose without milk? →	group ^ v →	period 1-5 →	durat. A/Li./feeding plan
14	Prescriptions	A / Powder ^ v →	A/Powder P1 - P2 →	dose without milk ?		
		A / Liquid ^ v →	A/Liquid P6 - P9 →	dose without milk ?		
15	Quantity Limits	Quantity limits ^ v →	group ^ v →	period 1 - 5 → minimum/maximum	duration limitation plan duration feeding plan	
		Carry over ^ v →	group ^ v			
16	Feeding Intervals	Group ^ v →	first / last interval		number of intervals	

Check Functions

20	Warning Levels	Feeding ^ v →	group ^ v →	consumpt. / dr. feed →	breaks w.o. A →	breaks w. A →	tot. robb.
		Concentrate ^ v →	group ^ v →	warning suppress. →	warning today →	warn.yester →	3-day w.
		LWG ^ v →	group ^ v →	<i>This function will only be displayed in case „Animal Scales“ has been activated in „Setup“.</i>			
21	List Printing	Warning list ^ v →	verification list				
22	Consumption Totals	MP ^ v →	A/Powder, A/Liquid →	C1/C2			
23	Interruption Check	Power failures ^ v →	backups →	water checks			
24	Fault Messages	<i>Delete Warning Messages with O/C Key.</i>					
25	Animal Scales	Box 1/2 connection test ^ v →	box 1/2 tare →	box 1/2 weigh			

Concentrate Functions

40	C1-Plan	Group ^ v →	periods 1 - 5 →	duration C1-plan → duration feeding plan	plan requirement	
41	C2-Plan	Group ^ v →	periods 1 - 5 →	duration C2-plan → duration feeding plan	plan requirement	
42	Quantity Limits	Minimum saved quantity ^ v →	group ^ v			
		Maximum quantity ^ v →	group ^ v			
		Carry over ^ v →	group ^ v			
44	Concentrate Intervals	Group ^ v →	first / last interval		number of intervals	
45	Wean. by Concentrate	Weaning by concentrate, group ^ v →			reshold value	
49	Connection Test	Test Silo 1 & 2 →	test Silo 3 & 4			

Delete Functions

90	Delete	Feeding/C ^ v →	feed delay group →	feed delay anim.No →	consump.group →	consumpt. animal No.
99	New Installation	All new ^ v →	work data			

Abbreviations and Symbols

A	additive	MP	milk powder	tot.robb	total robberies	as of vers. 7.0
autom./automat.	automatic	No.	number	wean.	weaning	
C./conc.	concentrate	P	prescription	w.	warning	
cons./consumpt.	consumption	Po.	powder	verific.	verification	
clean.	cleaning	prg.-vers.	program version	Ø	average value	
durat.	duration	rem.	remaining	^ v	Arrow Up, Arrow Down key is active	
Li.	liquid	Resp.	Responder	^	only in the display: Arrow Up, Arrow Down active	
mess.	message	suppress.	suppression	→	Arrow Right / Arrow Left key is active	