

Original Operating Instructions

Automatic calf feeder
Compact type Powder
Program version 8.00 and higher

TAP5-CH2-25



Table of contents

1	Introduction	7
1.1	Automatic feeder	7
1.2	Overview of the automatic feeder	9
1.2.1	Front and right side view of automatic feeder	9
1.2.2	Left-hand view of automatic feeder	10
1.2.3	Boiler with heating circuit	12
1.3	Technical data	12
1.3.1	Electrical connection	12
1.3.2	Dimensions of the automatic feeder	13
1.3.3	Weight	13
1.3.4	Water connector	13
1.3.5	Boiler	13
1.3.6	Milk powder container	13
1.3.7	Number of feeding stations and animals	14
1.4	Symbols and abbreviations	14
1.4.1	Symbols	14
1.4.2	Abbreviations	14
1.5	Contact details of the manufacturer	15
2	Important safety instructions	17
2.1	Intended use	17
2.2	Your requirements	17
2.3	Hazards arising from the automatic feeder	17
2.3.1	Material damage caused by the automatic feeder	19
2.4	Your obligations when handling the automatic feeder	19
2.5	What hazard warnings are provided?	20
2.5.1	Components of a hazard description	20
2.5.2	Hazards causing death or injury	21
2.5.3	Material damage	22
2.6	Safety labels on the automatic feeder	22
2.6.1	Warning signs on the machine	23
2.7	Safety equipment on the automatic feeder	24
3	Hygiene	27
4	Operating the automatic feeder	29
4.1	Offline mode	29
4.2	Hand terminal	30
4.2.1	The 15-key hand terminal	31
4.2.2	The 12-key hand terminal	34
4.2.3	Auto LED	35
4.2.4	Data backup	35
4.3	Menu structure	35
4.3.1	Symbols	36
4.3.2	Navigation	37
4.3.3	Menus	38
5	Shutting down and restarting the automatic feeder	41
5.1	Shutdown	41
5.1.1	Temporary shutdown	41
5.1.2	Permanent shutdown	43

5.2	Restart	44
5.2.1	Restart after temporary shutdown without change of location	44
5.2.2	Restart after long-term shutdown or change of location	46
6	Running the automatic feeder	47
6.1	Operating modes	47
6.1.1	Rationed mode	47
6.1.2	Ad lib mode (emergency mode)	47
6.2	Routine tasks	48
6.3	Transmitter and animal management	49
6.3.1	Managing transmitters	50
6.3.2	Registering animals	54
6.3.3	Canceling animals or animal groups	57
6.3.4	Changing the registration of animals	58
6.4	Cleaning the automatic feeder	59
6.4.1	Cleaning agents	60
6.4.2	Preparing for cleaning	60
6.4.3	Cleaning	61
6.5	Feeding	69
6.5.1	Replenishing feed	69
6.5.2	Feed preparation	70
6.5.3	Feed distribution	70
6.5.4	Feeding	70
6.5.5	Checking and changing feeding data for individual animals	73
6.5.6	Feeding plans	75
6.5.7	Winter feeding plan	81
6.5.8	Alarm levels	82
6.6	Animal control	83
6.6.1	Animal list	83
6.6.2	Entitled	84
6.6.3	Alarm	86
6.6.4	Plan over date	87
6.6.5	40FIT	87
6.6.6	Marked	88
6.6.7	New	90
6.6.8	Double	91
6.6.9	Unknown	91
6.6.10	All	92
6.6.11	Total consumption	93
6.6.12	Print	94
6.6.13	Searching for animals	94
6.7	Care and maintenance	95
6.7.1	Daily care and maintenance tasks	96
6.7.2	Care and maintenance tasks every 4 month	97
6.7.3	Annual care and maintenance tasks	101
7	Failures and warnings	103
7.1	Failures	103
7.1.1	CRC error	103
7.1.2	Heating	104
7.1.3	Temperature too high	104
7.1.4	Boiler not filled	105
7.1.5	Water shortage	106
7.1.6	Mixer emptying	106
7.1.7	Heating	107

7.1.8	Boiler temperature sensor	107
7.1.9	Calibration	108
7.1.10	Box/drain valve	108
7.1.11	Uncontrolled output	108
7.2	Warnings	109
7.2.1	Identification	109
7.2.2	Mixer emptying	109
7.2.3	Temperature sensor, mixer	110
7.2.4	Unknown transmitters	110
7.2.5	Calibration	111
7.2.6	Calibration scale	111
7.2.7	Double animal number	111
7.2.8	Machine capacity	112
7.2.9	Database	112
7.2.10	Checking the SD card (15-key hand terminal only)	112
7.3	Other failures and messages	113
7.3.1	Automatic feeder	113
7.3.2	Hand terminal	114
7.3.3	Bootloader	115
7.4	Service messages	115
8	Disposal	117
8.1	Disposing of residual cleaning agent	117
8.2	Disposing of hoses	117
8.3	Disposing of cables	117
8.4	Disposing of the hand terminal	117
8.5	Processor board	118
8.6	Disposing of the automatic feeder	118
9	Appendix	119
9.1	Feeding	119
9.1.1	Standard feeding plans	119
9.1.2	Basic principle of interval feeding	123
9.1.3	Milk powder conversion table (MP)	124
9.2	Automatic feeder material list	125
9.3	User maintenance instructions	126
9.3.1	Care and Maintenance schedule / routine work	126
9.4	Automatic feeder shutdown checklist	129
9.5	Recommissioning checklist	130

1 Introduction

This chapter explains how your automatic feeder is designed and how to operate it safely as intended.

Read the operating manual carefully before operating the automatic feeder and ask your service technician to explain anything that is unclear to you before you use it for the first time.

Do not operate the automatic feeder until you have read and understood the safety chapter (see Chapter 2 Important safety instructions, page 17). Resolve any questions with your service technician before operating the feeder.

The operating manual for the automatic feeder, the operating manuals of all additional equipment to be connected and the safety data sheets for cleaning agents must be kept readily available at all times and passed on to the next user.

Observe all of the warnings and safety instructions in this operating manual.

If your automatic feeder has additional equipment, you must also observe the separate operating manuals and the safety warnings and safety instructions for the additional equipment.

1.1 Automatic feeder

Modern calf rearing businesses primarily use feeding systems with individual animal identification functions. Calves are identified via their collar transponders or electronic earmarks and fed based on their individual requirements.

Feed is always prepared fresh and dispensed to calves in small portions at the temperature and concentration that you have specified.

The hand terminal provides quick and easy access to the controls of the automatic feeder when you are right near your animals. You can connect the automatic feeder to your PC via the CAN Ethernet Gateway and then control the feeder from your computer.

Your advantages:

- Added functions eliminate cumbersome routine tasks and save you time.
- Automatic cleaning programs improve feed hygiene.
- The hand terminal gives you quick access to important animal data.
- The animal control list provides a clear and easy way of monitoring animals.
- The automatic feeder offers you a wide range of options for feeding plans and recipes.
- You can expand the functionality of the automatic feeder by integrating concentrate feeders, animal scales and PC programs with graphical analyses.
- The automatic feeder's rugged and reliable design makes it easier to use in pens.
- The automatic feeder can be integrated into the feeding systems of well-known dairy technology manufacturers.

1.2 Overview of the automatic feeder

1.2.1 Front and right side view of automatic feeder

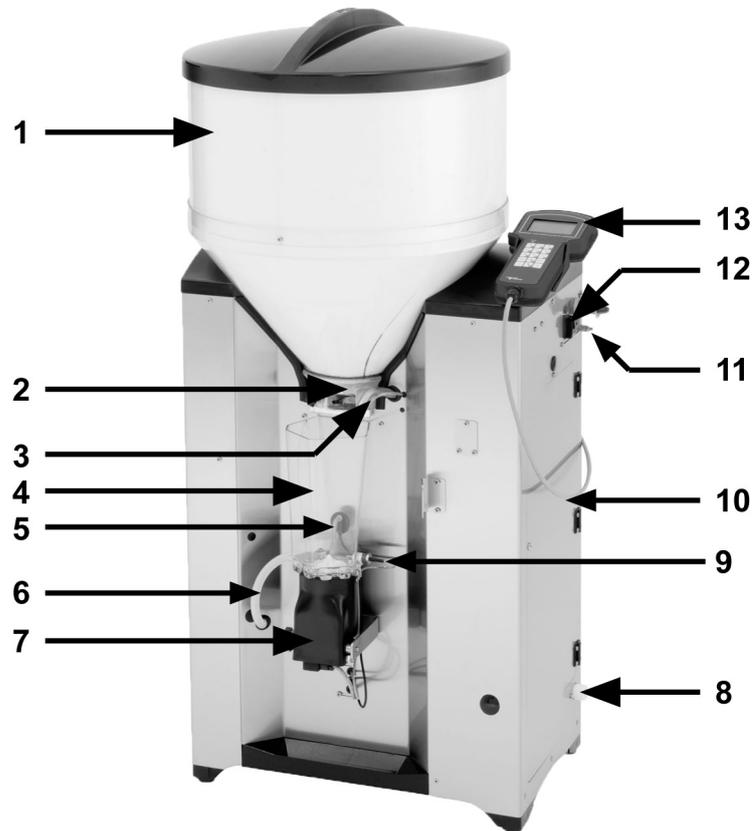

- | | |
|---|--|
| 1 Milk powder container | 8 Water connector |
| 2 Milk powder discharge | 9 Temperature sensor |
| 3 Water supply | 10 Right door |
| 4 Mixing jar | 11 Connection screw for potential equalization |
| 5 Bar electrode | 12 Control switch |
| 6 Hose connection from mixer to box valve | 13 Hand terminal |
| 7 Mixer motor | |

1.2.2 Left-hand view of automatic feeder

The name plate is located above the left side door on the outside of the automatic feeder. It contains information about the manufacturer, type and number of the automatic feeder, information for connecting the feeder to the the mains as well as the certifications of the automatic feeder. An example of a name plate is shown below.

Name plate

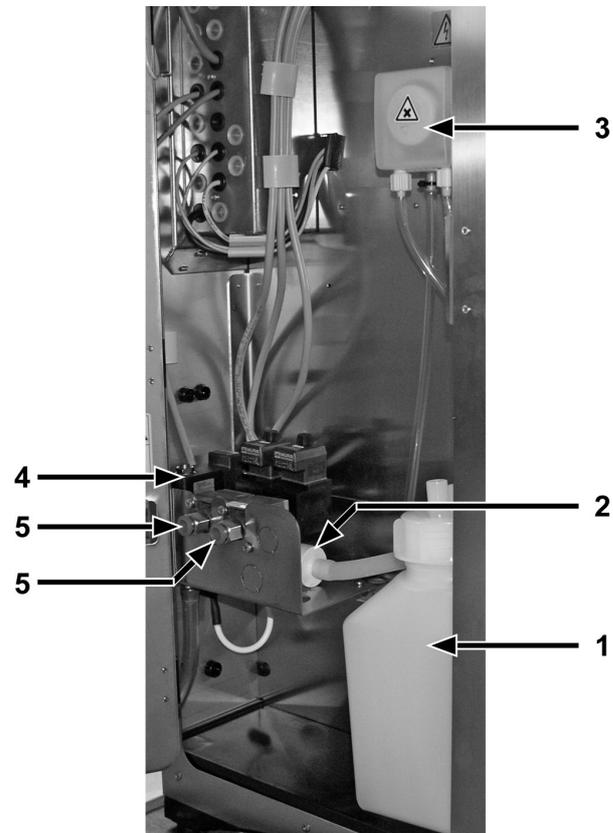

- 1 Name and address of the manufacturer
- 2 Type and number of the automatic feeder
- 3 Information for connection to the mains
- 4 Certifications of the automatic feeder

Behind the left side door

- 1 Storage container for detergent
- 2 Feeding pump
- 3 Detergent dosing pump
- 4 Mixer drain valve
- 5 Feeding station valve(s)

1.2.3 Boiler with heating circuit

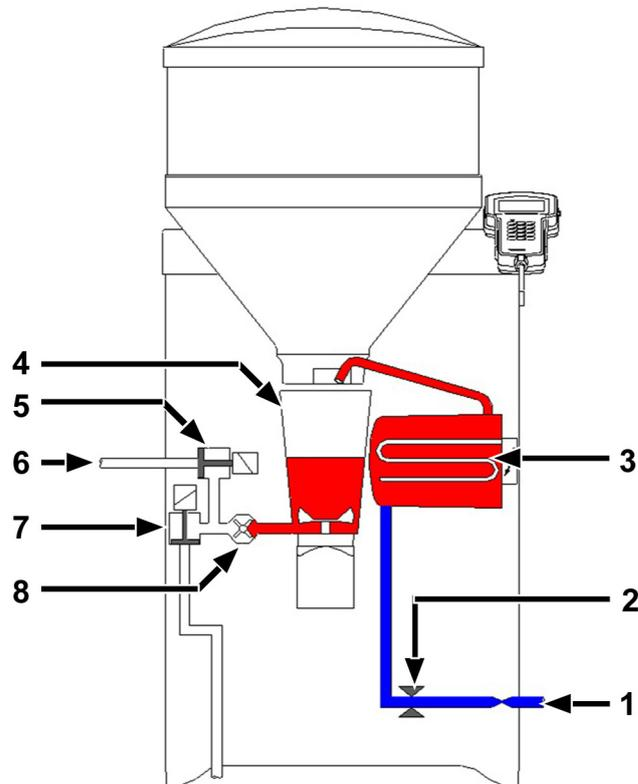

- | | | | |
|---|--------------------------------|---|--|
| 1 | Hose connection for water pipe | 5 | Feeding station valve |
| 2 | Boiler water valve | 6 | Hose connection between feeding station valve and teat |
| 3 | Boiler | 7 | Mixer drain valve (optional) |
| 4 | Mixer | 8 | Feeding pump |

1.3 Technical data

1.3.1 Electrical connection

Note: The electrical connection specifications for your automatic feeder is located on the name plate above the left side door on the outside of the automatic feeder (see **1.2.2** Left-hand view of automatic feeder on page **10**).

1.3.2 Dimensions of the automatic feeder

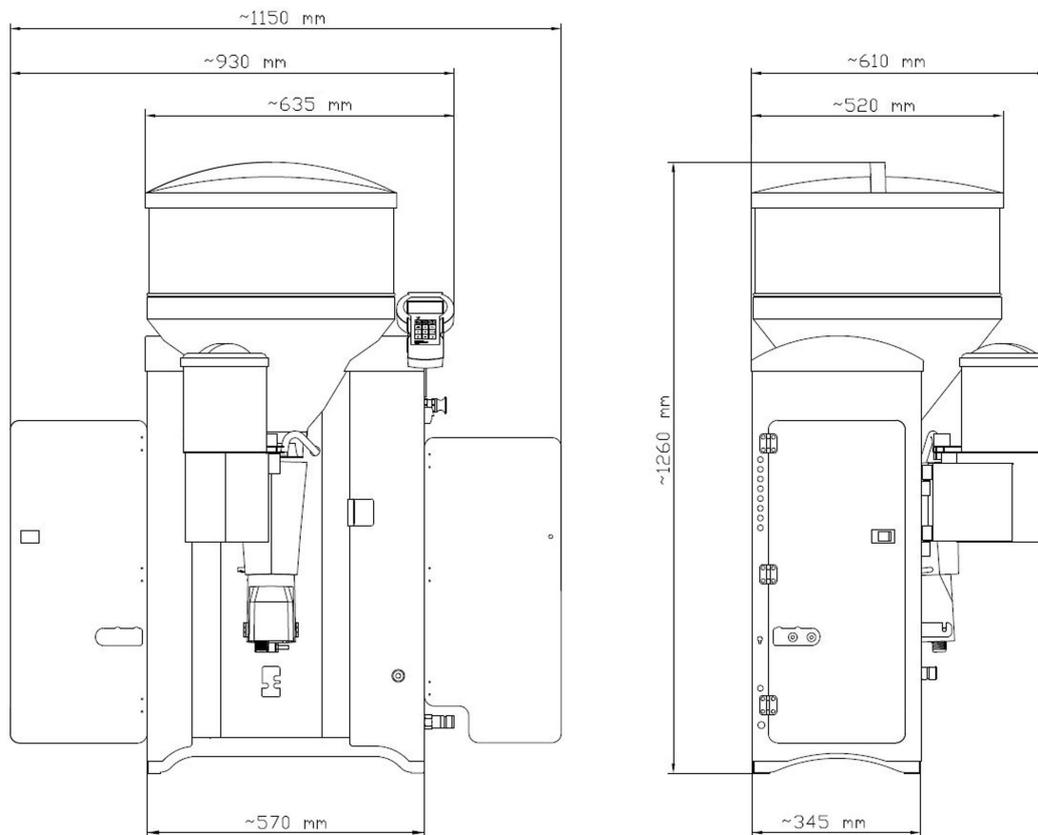

Depth when the fly protection door is opened ~ 690 mm

1.3.3 Weight

Approximately 80 kg.

1.3.4 Water connector

The water connection is made using a 1/2 inch hose with a 3/4 inch screwed connection.

The water pressure to be provided by the customer must be between 2.5 and 6 bar.

1.3.5 Boiler

The boiler holds approximately 7 l of water.

1.3.6 Milk powder container

The milk powder container with attachment holds approximately 35 kg of milk substitute.

1.3.7 Number of feeding stations and animals

Your automatic feeder has 2 feeding stations. You can feed up to 50 calves, with 30 calves per feeding station.

1.4 Symbols and abbreviations

1.4.1 Symbols

You can find a list of the symbols and abbreviations as used in this operating manual in the following.

-  The places in the text marked with this symbol only apply to the automatic feeder Compact.
-  The places in the text marked with this symbol only apply for the automatic feeder Compact+.
-  Option: A white plus sign on a black background indicates that optional functions or equipment are being described.

1.4.2 Abbreviations

Abbreviation	Meaning
abs.	Absolute
Ad lib	Ad lib
save amt.	Amount saved up
feed.pump	Feeding pump
out. pause	Output pause
sw.off del.	Switch-off delay
dr. time	Drink-out time
bo	Boiler
dos.	Dosage
El	Electrode
electrol.	Electrolyte
sw. on del.	Switch-on delay
gradient	Gradient control
gr. A (B)	Group A (B)
IFS TR	Intelligent feeding station feed
IFS KF	Intelligent feeding station concentrate
IV	Interval feeding program
KF	Concentrate
conc./concentr.	Concentration
dra.v. teat	Drain via teat
w. entitle.	With entitlement
w/add. or w/addiv.	With additive

MAP	Manual feeding pump
MP	Milk substitute
max	Maximum
Min. temp.	Minimum temperature
mix. full	Mixer full
mixer cl.	Mixer cleaning
mixer dr.valve	Mixer drain valve
n.	Not
No.	Number
Clean teat	Clean teat
w/o entitlement	Without entitlement
w/o add. or w/o add.	Without additive
P 1-5	Periods 1 - 5
rel.	Relative
Drinking speed	Drinking speed
ho.	Hose
clo.?	Close?
servo	Servo control
det. pump	Detergent pump
Temp.	Temperature
TR	Feeding station
fd.sensor	Feeding sensor
water bo.	Boiler water
inc./dec.	Increase/reduction
add. disp.	Additional dispenser

1.5 Contact details of the manufacturer

Please contact us if you have any questions on our products or require technical support.

When you contact us, always specify the model, serial number and program version of your automatic feeder in order to receive custom service for your unit.

The device number and model are located on the name plate on the left of the automatic feeder housing. When operating your automatic feeder for the first time, ask your service technician for the device number and model.

You can call up the program version via your hand terminal. The menu item for the program version can be found under  > **Diagnosis > Version > Feeder**. When operating your automatic feeder for the first time, ask your service technician for your program version.

You can note the device type, serial number and program version in the fields provided.

Device type:

Serial number:

Program version:

Our contact details:

Förster-Technik GmbH
Gerwigstrasse 25
D-78234 Engen, Germany
Phone: +49/ (0)7733/ 9406- 0
Fax: +49/ (0)7733/ 9406- 99
info@foerster-technik.de
www.foerster-technik.de

2 Important safety instructions

SAVE THESE INSTRUCTIONS!

This chapter outlines:

- The hazards caused by your automatic feeder and how to avoid them.
- The safety labels attached to the automatic feeder and what they mean.
- How to operate the automatic feeder safely.

The automatic feeder is state of the art and is produced in compliance with recognized safety regulations. However, hazards and adverse effects may arise when using it. Both warning signs directly on the automatic feeder and warning notices in this manual provide warning of these hazards.

2.1 Intended use

The automatic feeder may only be used for preparation, heating, and dosing of liquid feeds, for example milk, for calves.

2.2 Your requirements

You must have experience in calf rearing, many years of professional experience in agriculture and an excellent command of technical agricultural practice.

You must be familiar with accident prevention regulations and the generally recognized safety regulations.

2.3 Hazards arising from the automatic feeder

Hazards to health caused by the automatic feeder:

⚠ WARNING When using electric appliances, basic precautions should always be followed, including the following:

- Read all the instructions contained in the operating manual before using the automatic feeder.
- To prevent the risk of injury, close supervision is necessary when an appliance is used near children.

- Do not touch any moving components of the automatic feeder, for example the mixer blades.
- Only use genuine spare parts from the manufacturer.
- Turn off the automatic feeder and disconnect the mains plug before carrying out any maintenance or cleaning work on the automatic feeder.
- Do not use the automatic feeder outdoors.
- If connection is made to a potable water system, the system shall be protected against backflow.
- The following specific hazards are associated with the automatic feeder's electrical system:
 - **Electrical breakdown.** If there is an electrical or voltage breakdown, electric current flows through parts of the automatic feeder that are normally insulated. Contact can cause a fatal electric shock. Make sure that an earth leakage circuit breaker is installed.
 - **Short circuit, Indirect contact.** If there is a short circuit, current at many times the level of the operating current can flow. Contact can cause a fatal electric shock. Make sure that an earth leakage circuit breaker is installed.
- The solenoid valves and the pipes to the valves can reach temperatures of up to 70°C. Contact can cause burns. Do not touch the solenoid valves and pipes during operation.
- Liquid at temperatures of up to 70°C can spray out of the pipes to the valves. This can cause scalding. Do not touch the pipes during operation. Carry out the recommended maintenance on the hoses.
- The mixer and powder supply start up unexpectedly if a calf with feed entitlement approaches. This can crush or chop off fingers or hands. Never reach into the area of the mixer or powder supply while the automatic feeder is in operation. Only use the scraper supplied for cleaning the powder discharge opening.
- **Poisoning.** Additives that are fed to the calves may contain substances that are hazardous to human health. Avoid direct contact and always wear protective gloves and goggles when handling these substances.
- **Chemical burns.** The cleaning agent used for cleaning the automatic feeder contains caustic substances. These can cause severe injuries to the hands or the eyes. Avoid direct con-

tact and always wear chemical-proof protective gloves and goggles when handling the cleaning agent.

- **Excessive strain.** The automatic feeder weighs 80kg. Never attempt to carry it alone as this can cause excessive physical strain.

2.3.1 Material damage caused by the automatic feeder

The automatic feeder can cause the following types of material damage:

- **Infection.** Improper cleaning or incorrect operation can result in calves becoming infected by pathogens from the automatic feeder. This can lead to medical costs or to the death of the calves.
- **Corrosion.** Improper cleaning or maintenance can result in the automatic feeder ceasing to function correctly.
- **Loss of stability.** The automatic feeder must be set up on a level surface. Otherwise, the automatic feeder can tip up and suffer damage.

2.4 Your obligations when handling the automatic feeder

- Prevent misuse by children.
- Read the operating manual carefully before commissioning the automatic feeder and ask your service engineer to explain anything that you do not understand before you use it for the first time.
- Follow the health and safety and accident prevention regulations.
- Only clean the automatic feeder with the cleaning agents recommended in this manual (see **6.4.1** Cleaning agents on page **60**).
- When cleaning the automatic feeder, observe the safety instructions stipulated in the safety data sheet for the cleaning agent.
- Where the safety equipment specified in the safety data sheet for the cleaning agent, such as goggles and chemical-proof protective gloves, when cleaning the automatic feeder.
- Only operate the automatic feeder if it is in proper condition and is fully functional.
- Only operate the automatic feeder if the safety equipment is fitted and intact.

- Check the fitted safety equipment regularly to ensure that it functions properly. You will find a care and maintenance schedule in the Appendix (see **9.3.1.2 Maintenance intervals and activities** on page **127**), which provides recommendations of how often to check the different safety equipment.
- Inspect the automatic feeder visually for possible damage. You will find a care and maintenance schedule in the Appendix (see chapter **9.3.1.2 Maintenance intervals and activities**, page **127**), which provides recommendations of how often you should check different parts of the automatic feeder.
- Repair any damage to the automatic feeder, or if you are not authorized to or capable of doing this yourself, have it repaired by a service engineer.
- Never carry out any unauthorized modifications to the automatic feeder.
- Keep all safety labels on the automatic feeder in a legible condition. Replace damaged or illegible safety labels immediately. You can order new safety labels from Förster-Technik GmbH.
- Only use genuine accessories, spare parts, and wearing parts. These are available from your dealer.

2.5 What hazard warnings are provided?

Hazards are indicated directly on the automatic feeder by safety labels (warning signs, instruction and prohibition notices), and in the operating manual by specially marked hazard descriptions.

The warnings for hazards that can cause death or injury to people are emphasized more than those for material damage, for example through the colors, hazard words or symbols used.

Safety labels are an important element of the overall automatic feeder safety concept. They provide warnings about hazards and explain how to avoid them.

Make sure that all the specified safety labels are fitted to your automatic feeder and that they are in a legible condition. If the safety labels are difficult to read, replace them immediately. New safety labels are available from Förster-Technik GmbH.

2.5.1 Components of a hazard description

A hazard description is always made up of the following elements:

- The hazard word (Danger, Warning, Caution, Attention).
- The nature of the hazard (what could happen?).
- The location of the hazard (where can it occur?).
- The actions to take to prevent the hazard (what do I need to do?).

2.5.2 Hazards causing death or injury

Depending on their severity and the probability of them occurring, hazards that can cause death or injury to people are indicated by a hazard symbol  (warning triangle with exclamation mark) and the following hazard words:

- The word **DANGER** indicates an imminent hazard that will lead to death or serious injury.
 - Warning signs on automatic feeder: **DANGER** (white text on red background).
 - Operating manual:  **DANGER** (white text on black background).
- The word **WARNING** indicates a potentially hazardous situation that could lead to death or serious injury.
 - Warning signs on automatic feeder: **WARNING** (black text on orange background).
 - Operating manual:  **WARNING** (white text on black background).
- The word **CAUTION** indicates a potentially hazardous situation that could lead to minor injury.
 - Warning signs on automatic feeder: **CAUTION** (black text on yellow background).
 - Operating manual:  **CAUTION** (white text on black background).

The automatic feeder can cause the following hazards that can result in death or injury:

- Electrical breakdown.
- Short circuit, indirect contact.
- Electric shock.
- Spraying of liquids at high pressure.
- Burns, scalding.
- Unintentional, unexpected start-up.

- Excessive strain.
- Crushing, clipping, cutting or cutting off.
- Health hazards.
- Chemical burns.

2.5.3 Material damage

The word **Attention** indicates possible material damage. The automatic feeder or an object in its vicinity may be damaged, for example a calf.

- Prohibition signs on automatic feeder: a red crossed out pictogram in a white circle with a red border indicates that you are not allowed to do.
- Operating manual: **ATTENTION** (white text on black background).

The automatic feeder can cause the following material damage:

- Infection.
- Corrosion.
- Loss of stability.

2.6 Safety labels on the automatic feeder

Different safety labels are attached at the hazardous points on the automatic feeder. Warning signs, prohibition and instruction notices.

What are warning signs?

Warning signs consist of:

- A pictogram in a yellow triangle illustrating the potential hazard.

What are instruction notices?



Prohibition signs show a pictogram of the prohibited action in a red crossed out circle. See adjacent example. They illustrate what you are not allowed to do. In the example, the crossed out hose means that you are not allowed to use high pressure cleaners.

What are instruction notices?

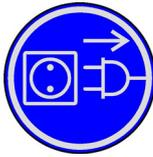

Instruction notices show a pictogram of what you are being instructed to do in a blue circle. They illustrate what you have to do. In the example, the pictogram means that you must always disconnect the plug first.

Other labels



Earthing label. You will see this label at the points where you need to install potential equalization.



Earthing label. You will see this label at the points where you need to connect a protective earth.

2.6.1 Warning signs on the machine

Danger of death by electric shock

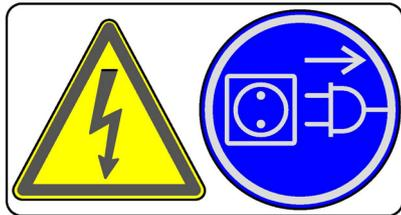

Burns, scalding



Health hazard due to additives



Chemical burns due to cleaning agent



Automatic start-up



2.7 Safety equipment on the automatic feeder

The automatic feeder may only be operated if the safety equipment is complete and intact. The automatic feeder has the following safety equipment:

- Safety labels (warning signs, instruction and prohibition notices).
- Heating safety temperature limiter. This shuts down the heating in case of overheating (temperature rises above 70°C). The heating may only be reactivated by a service engineer.
- Protective grid for the powder hopper attachment. The protective grid prevents people being injured by the rotating tools in the hopper, for example when adding milk powder. It must always be installed during operation.
- Scraper next to milk powder outlet. The powder discharge opening may only be cleaned with the scraper. This prevents finger and hand injuries caused by the mixer starting up automatically.

The safety devices at the machine are an important part of the safety concept and help prevent accidents.

- Do not remove or change the safety devices without observing the corresponding safety instructions.
- Put the machine into service only after all safety devices have been attached and are in protection position.

Safety temperature limiter

The heating of the automatic feeder is equipped with a safety temperature limiter which is triggered in the event of overheating (70°C) and consequently shuts down the heating.

The safety temperature limiter is triggered if the water gets too hot or if the heating is running dry.

The heating may only be reactivated by a service engineer.

Protective grid for powder hopper attachment

The protective grid for the powder hopper attachment prevents you from being injured by the rotating tools in the powder hopper, for example, when filling in milk powder.



1 Protective grid

⚠ WARNING Risk of injury due to rotating tools. The protective grid must always be fitted during operation.

Scraper next to milk powder outlet

The powder discharge opening may only be cleaned with the scraper. This prevents finger and hand injuries caused by the mixer starting up automatically.

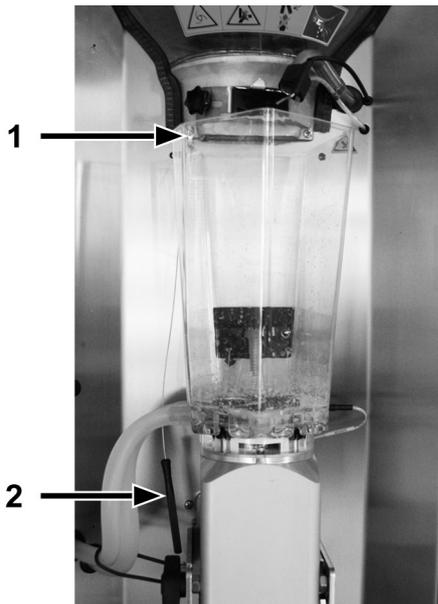

- 1 Mount for scraper
- 2 Scraper

⚠ WARNING Risk of injury due to automatic start-up. Do not reach into the hazardous area of the mixer. The mixer can start up automatically at any time, crushing or cutting off your fingers. Always turn off the automatic feeder with the control switch and disconnect the mains plug. Only use the scraper supplied for cleaning the powder discharge opening.

SAVE THESE INSTRUCTIONS!

3 Hygiene

As a farmer with experience in calf rearing, you understand how unhygienic conditions affect the health of your calves. Diarrhea and respiratory infections are frequently occurring infectious diseases in calves.

Every sick calf involves additional costs, for example for veterinarians and medication, and requires extra time for care.

The younger the calf, the weaker its immune system, and the more prone to infection it will be.

The possibility of infection can never be completely eliminated, but it can be minimized by taking measures to ensure good hygiene.

Maintaining cleanliness is one important and easy measure that helps prevent infectious diseases.

Through proper cleaning at regular intervals, every calf-rearing business can reduce the risk of infection for its calves and save money as a result.

Measures to ensure hygienic conditions save time and money.

What are infections? An infection is defined as the invasion and multiplication of germs in a host.

Germs are all around us. However, they are not dangerous until they multiply in great numbers. The risk of infection increases with the number of germs in an organism.

When germs get into your animal feed, such as milk, they can spoil the feed and make it inedible.

When germs get into your calves, for example from infected feed or other infected calves, your calves can become sick and die.

Both situations result in costs that you can minimize by taking measures to ensure hygienic conditions.

As a farmer, your job is to identify sources of infection and bring them under control.

So how do you prevent infections? Through good housing conditions, good drinking water and feed quality and, most importantly, through cleanliness.

Proper cleaning is an important way of ensuring hygienic conditions and also prevents infections.

If the automatic feeder is not cleaned or is cleaned improperly, germs, which are abundant in the environment, can enter the nutrient-rich feed and multiply. When they drink the feed, calves can become infected, sick and even die.

Proper cleaning of the automatic feeder reduces the number of germs and therefore the risk of infection.

The Cleaning (see chapter **6.4** Cleaning the automatic feeder, page **59**) chapter explains how to clean the automatic feeder properly. The appendix contains a table of suggestions for cleaning the different parts of the automatic feeder (see chapter **9.3.1.2** Maintenance intervals and activities, page **127**).

4 Operating the automatic feeder

This chapter explains how to operate your automatic feeder using the hand terminal.

The hand terminal is directly connected to your automatic feeder by a cable. You switch it on and off together with the automatic feeder. It remains in operation as long as the automatic feeder is switched on.

Note: After the hand terminal has been switched on, the program version of the hand terminal first briefly appears in the display, before the automatic feeder carries out a check routine. Do not press any buttons on the control panel during these start routines.

- You monitor and control the automatic feeder (the **feeding pump**, for example) directly via the keys of the hand terminal.
- You monitor and change the settings of the automatic feeder and the values of your calves via menus. The menus and sub-menus are arranged so that you can find the necessary settings quickly and easily. With a click of a button, you can access the most important menus, such as **Animal control**, **Main menu** and **Manual functions** as well as the **Animal list** (only with the 15-key hand terminal).

You can operate the automatic feeder in offline mode or in automatic mode.

4.1 Offline mode

In offline mode, you perform tasks that cannot be performed while the unit is in operation, such as recalibration of feed components. When the automatic feeder switches from automatic to offline mode, the Auto LED goes out.

You switch to offline mode when you press  or when you open a menu that requires offline mode, such as the Calibrate menu.

- Press .
 - Confirm the message **Exit automatic mode?** message by choosing .
- The Auto LED on your hand terminal goes out.
- Perform the desired action.

4.1.1 Automatic mode

You perform most routine tasks, such as feeding, in automatic mode. In automatic mode, the Auto LED lights up green.

You exit automatic mode by pressing .

After a prolonged period of inactivity, the automatic feeder automatically returns to automatic mode. This time period is defined during the initial startup process. The default setting is 20 minutes.

You switch from offline mode to automatic mode as follows:

- Press until the message **Start automatic mode?** appears in your display.
- Press .

You are now in automatic mode again. The Auto LED lights up green.

4.2 Hand terminal

The hand terminal is directly connected to the automatic feeder by a cable. The lighting of the display switches off when the unit is not used for a long period. This saves power.

4.2.1 The 15-key hand terminal

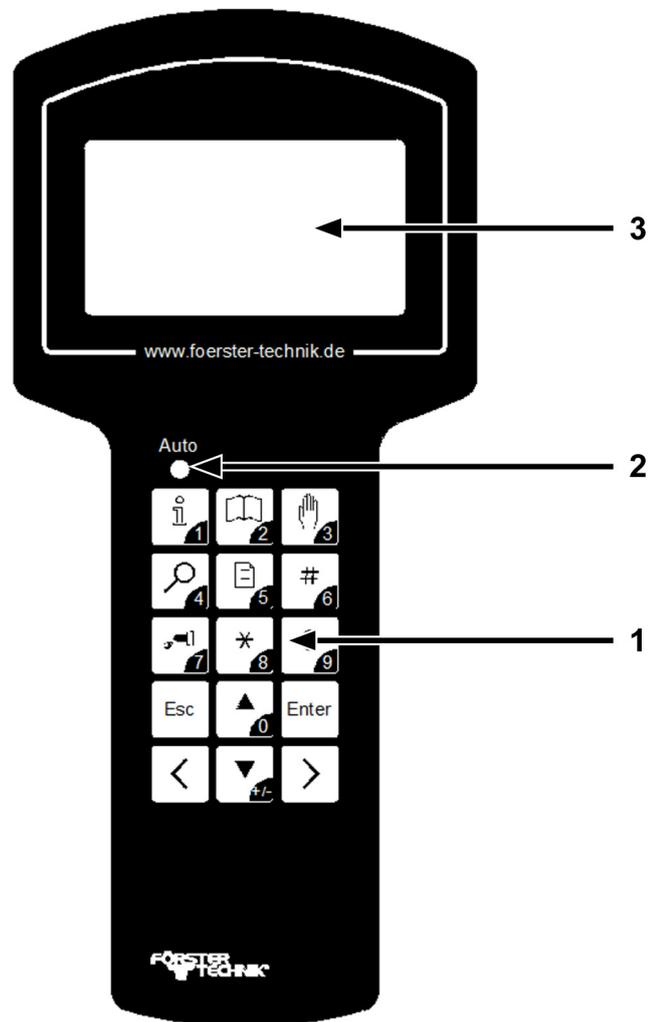

- 1 Keypad
- 2 Auto LED
- 3 Display

Keypad



With this key, you open the **Animal control** menu and enter the numeral 1.



With this key, you open the **Main menu** and enter the numeral 2.



With this key, you open the **manual functions** menu and enter the numeral 3.



With this key, you open the **Search functions** and enter the numeral 4.



With this key, you open the **Animal list** and enter the numeral 5.



Key 6 can be freely assigned. With this key, you enter the numeral 6.



With this key, you activate the **Feeding pump** and enter the numeral 7.



This key is assigned 2 functions:

You press this key to select a calf in submenus in which an animal number is displayed. An asterisk (*) is displayed in front of the animal number of a selected calf.

In the overview menu in automatic mode, you use this key to toggle between the four-line (large font) and the eight-line (small font) display.

With this key, you enter the numeral 8.



This key is assigned 2 functions depending on the menu you are currently in:

- In the Alarm submenu, you use this key to delete warnings and alarms.
- In the overview menu of automatic mode, you use this key to bring warnings to the foreground.

With this key, you enter the numeral 9.

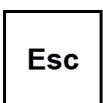

You use this key to go backward within the menu structure. You return to the starting menu by pressing this key multiple times.



You use this button to move the cursor upward and choose items from a list, for example [yes] or [no]. With this key, you enter the numeral 0.



With this key you move the cursor downward and select items from a list. You use this key to change the sign of a number, for example from +1 to -1. This is how you enter negative numbers.



You use this key to confirm your selection and open a menu such as an input field. An [input field] is indicated by square brackets.



You use this key to scroll between pages on the screen or list items to the left and jump to the end of a list.



You use this key to scroll between pages on the screen or list items to the right and jump to the end of a list.

4.2.2 The 12-key hand terminal

Older versions of the automatic feeder still have the hand terminal with 12 keys.

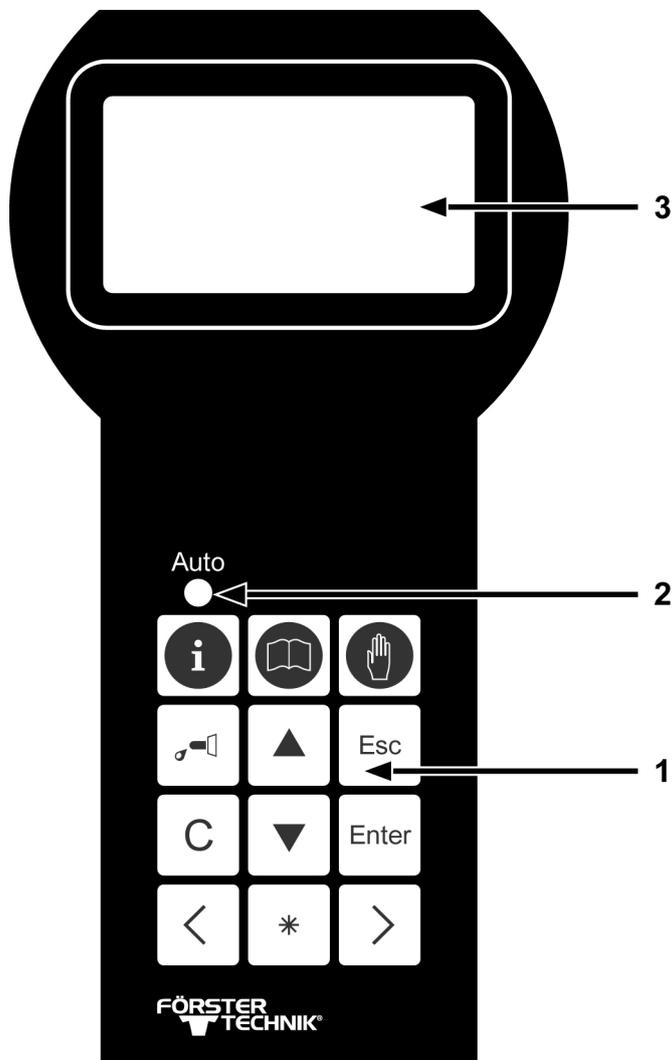

- 1 Keypad
- 2 Auto LED
- 3 Display

The operation of this hand terminal differs from the operation of the 15-key hand terminal in the following ways:

- You cannot enter numbers directly via the keypad. In the menu in which you would like to enter numbers, use to select a number and confirm your selection using .

- There are no freely assignable function keys. You access the animal list via the **Animal control** menu.
- You cannot save the data of the automatic feeder to an SD card.

4.2.3 Auto LED

The Auto LED (light-emitting diode) of your hand terminal displays important information about the status of the automatic feeder.

- In automatic mode, the LED lights up green.
- In offline mode, the LED is not lit up.
- In event of failures or warnings, the LED flashes.

4.2.4 Data backup

The automatic feeder performs an automatic data backup at night. You can also start the backup manually. The data of the automatic feeder can be stored on an SD card (only with the 15-key hand terminal).

4.3 Menu structure

The automatic feeder is controlled using menus, submenus and lists. You control your automatic feeder by switching to lists via menus and submenus. In these lists, you can view and change values. The menu structure makes it easier to find a list quickly.

The menus that you require most frequently, such as **Animal control** , **Main menu**  and **Manual functions**  can be directly accessed with the press of button. The **Animal list** is the list you will require most often. The animal list can be directly accessed on the 15-key hand terminal by pressing the . You can change this default setting. You can also access the animal list via the Animal control menu.

If your automatic feeder has the 15-key hand terminal, you can also assign an additional  key according to your needs in Device data under Function keys.

If you do not see all the menus or submenus presented here, this is either because your automatic feeder is not equipped with the component in question, or the component was not activated during setup.

Note: If you know that your automatic feeder has a component that is not being displayed, contact your service technician so that he/she can adjust your setup. Never adjust the setup yourself.

ATTENTION Changing the setup can cause the automatic feeder to malfunction. If the automatic feeder malfunctions, your calves could suffer from malnutrition. Malnutrition can cause impaired growth and development, increased susceptibility to illness or even the death of your calves.

4.3.1 Symbols

Different symbols are displayed in front of and in several menus, submenus and lists.

4.3.1.1 Position arrows

In automatic mode, position arrows are displayed in front of menus:

- ▶ A shaded arrow indicates that the menu contains submenus.
- ▷ An unshaded arrow means that you can change settings here or perform actions.

4.3.1.2 Angle brackets

  Angle brackets around a menu or list mean that you can choose between menu items or list items. For example, you can select the appropriate calf from a list of animal numbers using the calf's animal number. If you see angle brackets at the top of the display, it means you can scroll left and right.

4.3.1.3 Square brackets

[] Values or terms are in square brackets. When you press  the value / list item begins to flash in the input field. You can now use the number keys to enter values or use   to select values from a list, such as [yes] or [no].

Note: If you enter a value in an input field and the value is too high or too low, this value is automatically set to the highest (too high) or lowest (too low) possible value after you press .

4.3.1.4 Bar electrode free/covered

The following symbols appear at the top right of your display when animals are being fed in feed mode or when the mixer is being drained.



This symbol indicates that the mixing jar is full. The tip of the bar electrode is in the liquid.



This symbol indicates that the mixing jar is empty. The rod electrode is free.

4.3.1.5 Animal identification and feed consumption



The aerial symbol after a station number, such as TR 1 for feeding station 1, indicates that a calf has been identified at this station.

✓ A check mark after the aerial symbol means that calf identified at this box may consume feed here.



A lock symbol after the aerial symbol means that calf identified at this box may not consume feed here. For example, this could be because the milk ratio or the concentration of feed in the mixing jar does not match the feed settings for the identified calf.

- A hyphen after the box number indicates that no calf was identified at this box.

4.3.1.6 Plan tendency

The arrow on the right beside the animal number indicates the feeding phase the selected calf is now in.

↗ The feed quantity increases continuously, for example at the beginning of the feeding plan.

→ The feed quantity remains constant, for example in the middle of the feeding plan.

↘ The feed quantity is continuously reduced, for example at the end of the feeding plan.

4.3.1.7 Marking

* Marked calves are indicated by an asterisk to the left of the animal number.

4.3.1.8 Alarms

! An exclamation mark to the left of the animal number indicates that a calf has triggered an alarm.

4.3.2 Navigation

You use the keys of the hand terminal to navigate through menus, submenus and lists.

You can use   to:

- Navigate between the different submenus of a menu.

- Navigate between the items of a list, for example between [yes] and [no].

You can use   to:

- Scroll screen by screen through a menu, for example to the submenus on the next page or directly to the last menu item.
- Scroll through a list, for example through animal numbers. At the end of the list, the message **List end** appears in the display.
- When you enter numbers, switch between whole numbers, for example from 1 to 2 to 3.

You can use  to:

- Confirm an entry.
- Confirm a prompt or message shown on the display.
- Confirm a selection.
- Open menus and submenus.
- To open input fields, which are indicated by square brackets.
- Switch from the number before the decimal place to the number after the decimal place in input fields.

You can use  to:

- Go back one menu each time you press the key. You return to the starting menu by pressing this key multiple times.
- Exit the input field or return to the number before the decimal place in an input field.

4.3.3 Menus

4.3.3.1 Animal control

You can choose  to open the **Animal control** menu. This menu contains all the submenus you require for daily calf monitoring. The numbers next to the submenus indicate the number of calves recorded in the relevant submenu.

- **Animal list.** A table is displayed that shows you your calves, sorted by different parameters, such as visits to the feeding station.
- **Entitled.** A list of your calves is displayed, sorted by feed entitlement.

- **Alarm.** A list of calves that have triggered an alarm is displayed.
- **Plan over date.** A list of calves that have a plan over date is displayed.
- **40FIT Period.** A list of calves currently in the 40FIT period is displayed.
- **Marked.** A list of calves that you have marked is displayed.
- **New.** You can view newly registered calves here.
- **Double.** Here you assign a new animal number to calves that have been assigned a duplicate animal number.
- **Unknown.** Here you can check whether and when your automatic feeder recorded unknown animal numbers. You can correctly register the identified calves.
- **All.** A list of all calves is displayed.
- **Total consumption.** Several lists are displayed with the consumption amounts of all calves, individual calves and individual groups.
- **Print.** Here you can print out the alarm list and the feed list.

4.3.3.2 Main menu

You can choose  to open the main menu. This menu contains all submenus that you require for daily operation of the automatic feeder.

- **Animal management**
- **Feeding**
- **Calibration**
- **Device data**
- **Cleaning**
- **Diagnosis**

4.3.3.3 Manual functions

You can choose  to open manual functions. Here you can start certain functions of the automatic feeder manually. For example, you can manually empty the mixer or dispense extra portions.

When you press , the message **Exit automatic mode?** appears in the display. When you confirm the message by choosing , you switch the automatic feeder from automatic mode to manual mode. The Auto LED goes out.

The automatic feeder automatically returns to automatic mode after 20 minutes of inactivity. The Auto LED lights up green.

You can also actively switch the automatic feeder back to automatic mode. Press until the message **Start automatic mode?** appears in the display. Confirm the message by choosing . The automatic feeder returns to automatic mode. The Auto LED lights up green.

You can start the following functions manually:

- **Extra portion.** Here you can dispense extra portions with and without additives.
- **Mixer: drain?.** The mixer is emptied via the mixer drain valve or via the teat of the feeding pump.
- **Boiler water: start?.** You fill the boiler with water here.
- **Mixer: start?.** You start the mixer here.
- **Feeding station.** You open the feeding station valve(s) here.
- **Hoses: open?.** Here you can open several valves simultaneously in order to completely drain all the lines of the automatic feeder of water.

5 Shutting down and restarting the automatic feeder

This chapter explains how to shut down the automatic feeder temporarily or permanently and restart it.

5.1 Shutdown

You can shut down the automatic feeder temporarily or permanently.

To make the procedure easier and ensure that you do not miss any steps, see the check list **Shutting down the automatic feeder** in the appendix (see chapter 9.4 Automatic feeder shut-down checklist, page 129).

5.1.1 Temporary shutdown

You can temporarily shut down the automatic feeder, for example from the end of the calving season to the start of the next calving season.

If you are shutting down the automatic feeder for a prolonged period of more than one year, you should store the feeder in an upright position in a clean, dry and frost-free location.

In addition, observe the following rules when transporting the automatic feeder:

- **▲ CAUTION** Health hazards caused by lifting heavy loads. Do not move the automatic feeder by yourself.
- The automatic feeder must always be transported in an upright position.

To ensure that the automatic feeder does not become a breeding ground for germs, which could endanger the health and life of your calves when you restart the feeder, you must clean the automatic feeder before shutting it down.

Depending on how your automatic feeder is configured, you must run the manual or automatic cleaning programs for the mixer, heat exchanger, hoses, teat and powder and milk container.

After cleaning, you must interrupt the power and water supply drain the boiler, seal the cable glands for aerials with dummy plugs and drain the water from the magnetic valves and the volume control valve.

To shut down the automatic feeder, proceed as follows:

▲ WARNING Chemical burns from cleaning agents. The cleaning agent can cause chemical burns to the eyes or hands. Always wear goggles and chemical-proof protective gloves when

disposing of cleaning agents. Follow the safety instructions listed in the safety data sheet for the cleaning agent and use the safety equipment specified.

1. Start the maximum possible number of cleaning programs (see chapter **6.4** Cleaning the automatic feeder, page **59**).
2. Drain the water from the boiler, magnetic valves, pressure-reducing valve or the volume regulator to prevent the automatic feeder from being damaged by frost.

ATTENTION Risk of damaging the automatic feeder. Frozen water expands and can damage automatic feeder components that contain water, such as the magnetic valves.

2.1 Close the water tap that supplies water to the automatic feeder.

2.2 De-pressurize the hoses by dispensing water into the mixing jar.

2.3 Press .

2.4 Confirm **Bo. water start?** by choosing .

▲ DANGER **Lethal electric shock.** The electrical components of the automatic feeder are live. Before continuing, always turn off the automatic feeder using the control switch and disconnect the mains plug.

3. Turn off the automatic feeder using the control switch and disconnect the mains plug.
 - 3.1 Disconnect the water hose between the water magnetic valve and the Boiler.
 - 3.2 Open the vent screw on the cover of the heat exchanger. As soon as air flows in, the water will drain.
 - 3.3 Let the water drain completely.
 - 3.4 Reattach the water hose.
4. Disconnect the water hose from the water tap that supplies the automatic feeder with water and from the water connector of the automatic feeder.
5. Dispose of the water hose. New hoses are available from your dealer.

ATTENTION Risk of infection. To prevent infections, use a new hose when restoring the unit to service.

6. Pour the liquid from the mixer into a container or the drain.
7. Disconnect the hose from the teat to the feeding station valve or the mixer jar.

8. Dispose of the hose. New hoses are available from your dealer.

ATTENTION Risk of infection. To prevent infections, use a new hose when restoring the unit to service.

9. If your automatic feeder is equipped with a mixer drain valve, disconnect the hose that runs from the drain channel to the mixer valve.

10. Seal the cable glands of the aerials with dummy plugs.

ATTENTION Moisture can enter the control box through the cable glands for the aerials and damage the control box.

11. Clean the outside of the automatic feeder using a damp cloth. Clean all areas that are not reached by the cleaning program.

ATTENTION Pressure washers can **damage** the automatic feeder. Only clean the automatic feeder by hand using a damp cloth.

12. Empty the powder container.

13. Unscrew the screws that attach the protective grid of the powder container. Remove the protective grid.

14. Clean the powder container and the dosing unit. (see chapter **6.4.3.6** Thorough cleaning of the powder container with the dosing unit, page **68**). To do this, use the scraper supplied.

15. Cover the automatic feeder with a tarp. This will protect it from dirt.

5.1.2 Permanent shutdown

If you are going to permanently shut down the automatic feeder, you must dispose of it in accordance with the law. To find out which regulations apply to you, contact your waste disposal company or a waste disposal center listed in the yellow pages.

In the appendix of the operating manual, you will find a list of the materials of which the automatic feeder is comprised (see **9.2** Automatic feeder material list on page **125**).

- Perform steps 2 to 15 of the shutdown (see chapter **5.1.1** Temporary shutdown, page **41**). You do not have to perform step 1, cleaning.
- Dispose of residual cleaning agent. See the cleaning agent manufacturer's technical data sheet for more information on disposal of the cleaning agent.

⚠ WARNING **Chemical burns** from cleaning agents. The cleaning agent can cause chemical burns to the eyes or hands. Always wear goggles and chemical-proof protective gloves when disposing of cleaning agents. Follow the safety instructions listed in the safety data sheet for the cleaning agent and use the safety equipment specified.

- Dispose of the automatic feeder as described in the Disposal chapter (see chapter 8 Disposal, page 117).

5.2 Restart

If you have temporarily shut down your automatic feeder for less than a year and kept it in its location, you can reconnect it and restart it yourself. The data in the automatic feeder is usually retained. However, if this data is lost (e.g., when the battery is depleted), contact your service technician immediately.

If you have shut down the automatic feeder for more than a year and removed it from its location, it may only be reconnected and restarted by a service technician.

5.2.1 Restart after temporary shutdown without change of location

In the following description, we are assuming that you have only disconnected your automatic feeder from the water and power supply.

You can reconnect these lines yourself. To make the procedure easier and ensure that you do not miss any steps, see the check list for restarting the automatic feeder (see chapter 9.5 Recommissioning checklist, page 130) in the appendix.

Proceed as follows to restart the automatic feeder:

1. Remove the cover.
2. Clean the outside of the automatic feeder with a damp cloth.
3. Install the protective grid for the powder hopper attachment. Screw the screws back into the holes provided. The protective grid for the powder hopper attachment prevents you from being injured by the rotating tools in the powder hopper, for example, when adding milk powder.
4. Using a clean new water hose, connect the water connector of the automatic feeder to the water tap that the service technician prepared for the automatic feeder during initial startup.

5. Connect the teat to the feeding station valve (rationed mode) or the mixer jar (ad lib mode). Use a new hose for this connection.

ATTENTION The hose must be installed at a gradient to the automatic feeder without sagging. This makes it easier for calves to consume feed and facilitates draining the hose (see figure).

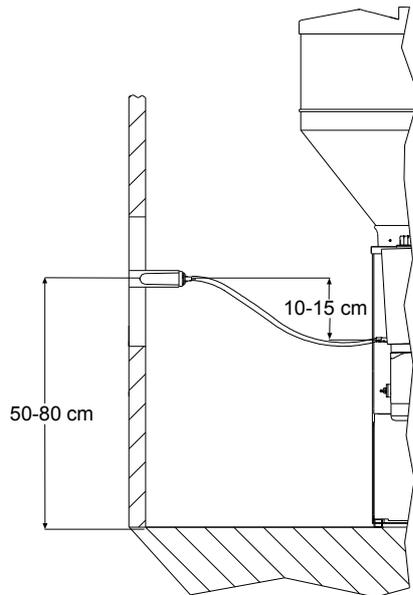

Hose with gradient between teat and feeding station valve

If your automatic feeder has a mixer drain valve, connect the mixer drain valve to the drain channel. Use a new hose for this connection.

6. Insert the mains plug into the outlet that your service technician created for the automatic feeder during initial startup.

7. Switch on the automatic feeder using the control switch.

Failure, HE not filled appears in the display of the hand terminal.

8. Press .

9. Choose  > **Device data** to go to the **Time** or **Date** submenu.

- In **Time**, you enter the time of day using the number keys.
- In **Date**, you enter the date using the number keys.
- In **Format**, you use to select the desired date format.

10. Clean the automatic feeder.

Start the cleaning programs for the mixer, hoses and the powder container (see chapter **6.4** Cleaning the automatic feeder, page **59**).

By doing this, you prevent germs that enter the automatic feeder from multiplying and infecting your calves.

11. Fill the powder container with milk substitute (MP). Use only milk substitute that is suitable for feeding calves.

ATTENTION Make sure that no paper or other foreign objects enter the powder container. This could damage the dosing mechanism or impair dosing accuracy.

5.2.2 Restart after long-term shutdown or change of location

If your automatic feeder has been shut down for a long period or moved to another location, it may only be restarted by your service technician.

6 Running the automatic feeder

This chapter explains how to operate your automatic feeder.

6.1 Operating modes

You can operate your automatic feeder in **rationed mode** or **ad lib mode** (emergency mode).

6.1.1 Rationed mode

In **rationed mode**, the automatic feeder uses animal identification. You can custom-feed your calves.

When calves are registered in a group, they receive feed in accordance with the feeding plan of that group. You can also feed individual calves differently from the group feeding plan. For example, you can feed extra portions to a single calf.

If the mixer jar is empty and a calf with a feed entitlement enters the feeding station and is identified, the automatic feeder prepares a feed portion that is specially adjusted for the calf.

- If the calf finishes this portion and is still entitled to feed, a second portion is prepared.
- If the calf is no longer entitled to feed, the feeding station valve is closed after the mixer is emptied and closed after a drink-out time that you have defined. You define the drink-out time in coordination with your service technician during initial startup.
- If a calf stops feeding before finishing its portion, the feeder handles the remaining feed as follows:
 - The remaining feed is dispensed to each calf with a feed entitlement. The remaining feed is used for the calf that actually finishes it.
 - Feed that remains in the mixer jar is automatically evacuated after a period that you define in **Device data > Portion > Draining**.

Note: This function should not be disabled. Otherwise, the risk of infection could increase.

6.1.2 Ad lib mode (emergency mode)

In **ad lib mode**, the feeder does not use animal identification. Whenever the mixer jar is empty, i.e., when the bar electrode is not covered by feed in the mixer jar, the automatic feeder prepares a portion of feed. Since the automatic feeder is not using animal identification, custom

feeding is not possible. You can only feed calves together if they are the same age and have the same feed entitlement.

If there are several feeding stations, then the respective feeding station valves are opened.

⚠ WARNING Risk of burns on feeding station valves. During prolonged ad lib mode, feeding station valves become hot. You can burn your fingers or hand when touching these valves. For this reason, push the suction hose directly onto the mixer jar spout and disconnect the device plug from the feeding station valve.

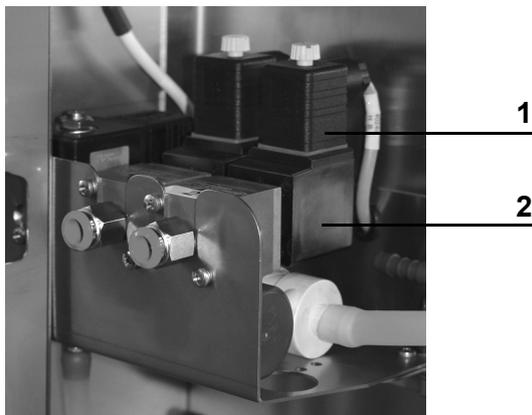

1	Female power connector
2	Box valve

⚠ ATTENTION Cleaning agent that enters the feed can be hazardous to the health of calves. Therefore, always disable all time-controlled cleaning menus during ad lib mode.

6.2 Routine tasks

Daily operation of the automatic feeder involves routine tasks such as cleaning, feeding, animal control and care and maintenance. This chapter explains how the automatic feeder facilitates these routine tasks for you. See the appendix for check lists (see chapter **9.3.1.2** Maintenance intervals and activities, page **127**) with the necessary cleaning and maintenance tasks.

Daily tasks:

- Clean the automatic feeder.
- Feed the calves.

- Animal control.
- Care and maintenance.

Weekly tasks:

- Care and maintenance.

Every 4 month tasks:

- If the automatic feeder does not have a mixer scale, recalibrate the water, milk substitute and cleaning agent.
- If the automatic feeder does have a mixer scale, recalibrate the cleaning agent.
- Care and maintenance.

Annual tasks:

- Thoroughly clean the automatic feeder.
- Replace wearing parts.
- Care and maintenance.

6.3 Transmitter and animal management

All menus for management of the list of all transmitters and the calves registered at the feeder can be found via  > **Animal management**.

6.3.1 Managing transmitters

6.3.1.1 Basics

6.3.1.1.1 Identification process at the box

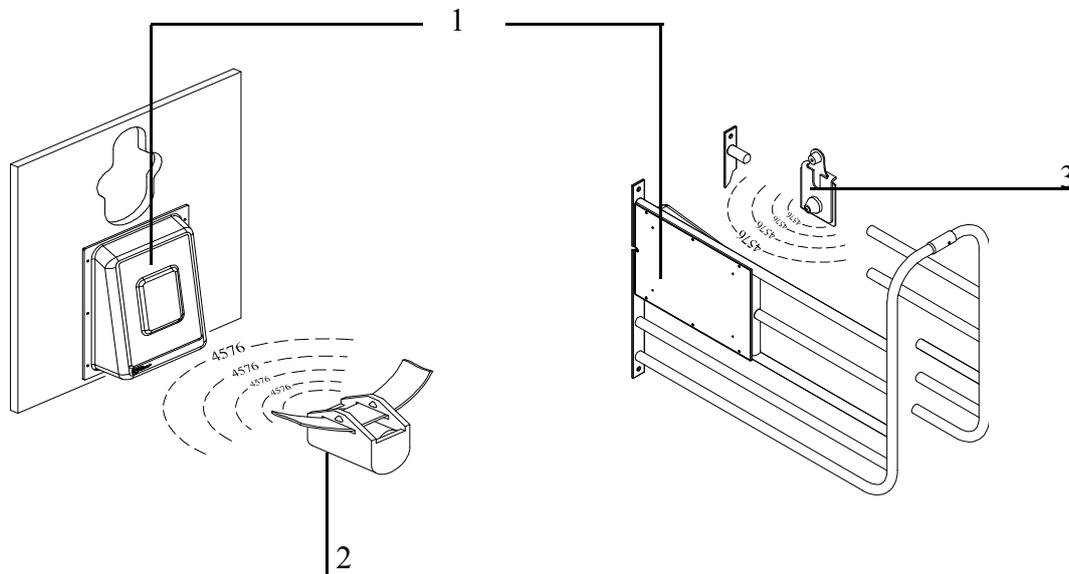

1	Aerial
2	Collar transmitter
3	Earmark transmitter

For identification purposes, each calf wears a collar with a transmitter or an earmark with a transmitter. The transmitter has a multi-digit number, which is also usually stamped into the transmitter housing. This **transmitter number** is sent from the transmitter to the aerial, which is part of the feeding station.

6.3.1.1.1 Connection of transmitters and animal numbers

The multi-digit transmitter number is not well suited for rapidly locating individual calves. For this reason, a calf is issued an animal number along with the transmitter number. The animal wears this animal number on an easily readable collar, or the animal number is put on the earmark where it can be easily read. Up to 250 different animal numbers of up to six digits can be assigned to the calves.

6.3.1.2 Creating transmitter numbers

During the initial startup process for the feeder, existing transmitters have to be created once in the system. When you do this, each transmitter number is assigned one animal number of

no more than six digits. These animal numbers are then available and can be used to register the calves.

6.3.1.2.1 Reading transmitter numbers

When creating new transmitter numbers, it is a good idea to have these read by the feeder. This saves you from typing in the numbers and eliminates the possibility of typing errors.

To set up the reading of transmitter numbers by the feeder, proceed as follows:

1. Choose  > **Animal management > Transmitters** to go to the **New** submenu.
2. Hold a transmitter next to the identification unit of a feeding station.
The number of the transmitter is read and displayed in the line behind **No.**. At the same time, the animal number to be newly assigned is proposed in the **Animal No.** line.
Note: You can influence the suggested animal number by selecting an assignment scheme for the animal numbers in the **No.** line.
3. Check whether the suggested **animal number** is correct and, in the line **accept?**, press .
4. In order to allocate the newly read transmitter number to the displayed animal number, confirm the security prompt **Create new no. xxx for animal xx?** by choosing .

6.3.1.2.1 Manually entering transmitter numbers

Instead of reading the transmitters, you can also manually type in the transmitter numbers, if necessary

You manually enter transmitter numbers as follows:

1. Choose  > **Animal management > Transmitters** to go to the **New** submenu.
2. Enter the transmitter number in **No.**
3. In **Animal No.**, check the suggested animal number and confirm it by choosing .
4. Confirm **accept?** by choosing .
5. In order to allocate the entered transmitter number to the displayed animal number, confirm the security query **no. xxx for animal xx create new?** by choosing .

6.3.1.3 Assigning animal numbers

If the transmitter numbers are automatically read when new numbers are created, an animal number is automatically suggested. When doing this, there are two schemes to choose from for number assignment.

6.3.1.3.1 Consecutive assignment of animal numbers

There is a counter which counts up for each new transmitter number as it is read. In this way, all of the transmitter numbers that are registered by the identification function are linked to consecutive animal numbers; e.g., from 1 to 50.

You set up consecutive assignment of animal numbers as follows:

1. Choose  > **Animal management** > **Transmitters** to go to the **New** submenu.
2. Select the **consecutive** option in **No.**.
3. If necessary, in **next**, specify the animal number at which you want automatic reading of transmitters to start.

Note: If you use collars, it makes sense to start with 1 and read the transmitters in order.

6.3.1.3.1 Assignment of animal numbers based on transmitter numbers

More and more often, calves are already equipped with an electronic earmark transmitter when they are born and keep this earmark their whole lives. The automatic feeder program has been adapted for this type of transmitter so that the registration process of the transmitters and calves can take place completely automatically.

You set up automatic assignment of animal numbers as follows:

1. Choose  > **Animal management** > **Transmitters** to go to the **New** submenu.
2. Select the **automatic** option in **No.**.
3. In **Range**, define the numeral range of the transmitter number that you want to use as the animal number. The animal number can have a maximum of six digits.

Example:5-2 means that – counting from the right – the second to the fifth numeral of the transmitter number is accepted as the animal number. **6-1** means that – counting from the right – the first to the sixth numeral of the transmitter number is accepted as the animal number.

6.3.1.4 Editing transmitters or animal numbers

If necessary, (e.g., if a transmitter is lost), a transmitter number can be subsequently changed or deleted.

6.3.1.4.1 Changing the transmitter number

Manually changing the transmitter number

You manually change a transmitter number as follows:

1. Choose  > **Animal management > Transmitters** to go to the **Edit** submenu.
2. Select the transmitter number to be changed.
3. Change the transmitter number in **No.** and confirm by choosing .

Reading the new transmitter number for the change

You read a new transmitter number as follows:

1. Choose  > **Animal management > Transmitters** to go to the **Edit** submenu.
2. Select the transmitter number to be changed.
3. Confirm **read?** by choosing .
- A new menu is displayed, and the transmitter number flashes in the first line.
4. Hold the transmitter that you want to read next to the identification unit.
The number is automatically accepted in the first line.
5. Confirm **accept?** by choosing .

6.3.1.4.1 Changing the animal number

Like the transmitter number, the animal number can also be changed.

1. Choose  > **Animal management > Transmitters** to go to the **Edit** submenu.
2. Select the animal number you want to change.
3. In **Animal No.**, change the animal number that is currently allocated to the transmitter and confirm by choosing .

6.3.1.4.1 Deleting transmitter numbers

You delete transmitter numbers as follows:

1. Choose  > **Animal management > Transmitters** to go to the **Edit** submenu.

2. Select the transmitter number to be deleted and confirm **delete** by choosing .

Note: You can only delete transmitter numbers from calves that are not registered (= status: available).

6.3.1.5 Deleting the transmitter number when cancelling an animal

Generally, the collars (or earmarks) with the respective transmitters remain at the organization and are reused after the calf is taken out of the pen and cancelled. For this reason, the default setting when cancelling of a calf is to not delete its transmitter number. If the transmitter of a calf is, however, **not** reused but rather stays with the calf, (lifelong earmark), make the following setting in the feeder:

1. Choose  > **Animal management** > **Cancel** to go to the **Settings** submenu.
2. Select the **yes** option in **Delete no..** When a calf is canceled, the transmitter number is also deleted along with the animal number. This prevents an accumulation of unused transmitter numbers, which would use up the available storage space.

6.3.1.6 Calling up the transmitter statistics

You call up a transmitter statistic as follows:

1. Choose  > **Animal management** > **Transmitters** to go to the **Information** submenu.
2. An overview of the transmitters created in the system is displayed. The following is listed in the displayed list:
 - In **Registered**, you check the number of registered transmitters or calves.
 - In **Available** you check the number of available transmitters.
 - In **Free**, you check how many transmitters you can still create.

6.3.2 Registering animals

Calves are only fed at the feeder if they are also registered there. You can either manually register each calf or instruct the feeder to automatically register the calves. In the latter case, the calf is registered as soon as it enters the feeding box for the first time. This means that the manual registering of the calves is not needed.

During registration, the calf is allocated to one of four groups, A to D. The calf will then be fed in accordance with the feed and concentration plans of this group.

The group to which you allocate the calves depends solely on the feed quantity, concentration and milk ratio that the end user wants to feed the calves. In this case, it does not matter which box the calves consume their feed in or which pen the calves have been housed in.

6.3.2.1 Registering animals manually

You register animals manually as follows:

1. Choose  > **Animal management** > **Register** to go to the **Animal** submenu.
2. Select one of the available (not yet registered) animal numbers.
3. In **Group**, select the group to which the calf is to be allocated.
4. If you want to reduce the total feeding duration for the calf, you can set this up under **Correction days** (see **Operation** > **Feeding** > **Total feeding duration** in the operator's manual).
5. Confirm **register?** by choosing .
6. Confirm the prompt **Animal xx in group X register?** by choosing .

Note: On its registration day, the animal receives the exact amount of feed, spread over the course of the day, as is intended for it by the feeding plan for the first day. If you have entered correction days, then the animal will receive the feed that is intended for the respective day.

6.3.2.2 Registering animals automatically

If an animal that is not yet registered enters the feeding box for the first time, it can then be automatically registered. With regard to automatic registration, three different modes can be set which are described in detail in the following three subchapters. The following table presents an overview of this.

Overview of the three modes for automatic registration

Automatic registration mode	Transmitter number in identification	
	available	unknown
deactivated	Unknown transmitters warning	Unknown transmitters warning
available transmitters	Animal is registered	Unknown transmitters warning
all transmitters	Animal is registered	Transmitter is created, new animal number is assigned, animal is registered

6.3.2.2.1 Deactivating automatic registration

Automatic registration is deactivated by default. You can restore this setting at any time:

You deactivate automatic registration as follows:

1. Choose  > **Animal management** > **Register** to go to the **Automatic** submenu.
2. Select in **Mode no** and confirm by choosing . Automatic registration is then deactivated.

Note: When the registration function is deactivated, the **unknown transmitters warning** is triggered if an unregistered calf enters a box.

6.3.2.2.1 Only automatically register available transmitters

Automatic registration shortens the registration process for the calves. When doing this, you can specify that only calves can be registered whose transmitter numbers are already in the system. If an available transmitter number is registered in the identification unit, the respective calf will be automatically registered. Calves or transmitter numbers that have not yet been created in the system trigger the **Unknown transmitter numbers** warning.

Proceed as follows to set up automatic registration of available transmitters:

1. Choose  > **Animal management** > **Register** to go to the **Automatic** submenu.
2. Select the **available** option in **Mode**.
3. In **Group**, choose the group in which you want to automatically register the calves.

Note: Those calves that are to be removed should only be deregistered after they have left the pen, since they will otherwise be automatically reregistered when they enter the box and will then be returned to the start of the feeding plan.

6.3.2.2.1 Creating transmitter numbers and automatically registering calves

In order to shorten the registration process even more, you can specify that calves can also be registered if their transmitter numbers are not known in the system. This eliminates the need for reading or manual entry of transmitter numbers. In this case, if an unknown transmitter number is registered in the identification unit, this transmitter number is automatically created in the system and a new animal number is issued and registered at the same time.

Note: When creating new transmitters and animal numbers, the animal number is assigned consecutively or as a part of the transmitter number (see **Animal number assignment**). Clarify whether this kind of number assignment is actually what the end user wants.

Proceed as follows to create transmitter numbers and automatically register calves:

1. Choose  > **Animal management** > **Register** to go to the **Automatic** submenu.
2. Select the **All** option in **Mode**.
3. In **Group**, choose the group in which you want to automatically register the calves.

Note: Calves **without collars** may never be in the pen. They could push other animals out of the way and steal remaining amounts.

6.3.3 Canceling animals or animal groups

Individual calves or a group of calves that are no longer being fed according to the plan must be removed from the pen compartment and canceled. The same applies to calves whose feeding plan has expired.

6.3.3.1 Cancelling individual animals

You cancel an individual animal as follows:

1. Choose  > **Animal management** > **Cancel** to go to the **Animal** submenu.
2. Select the desired animal number.
3. In **Plan end**, you check how much longer the calf is to be fed according to the plan.
4. In **MP**, you can check how much milk powder the calf has consumed from registration to cancellation.

5. Confirm **cancel?** by choosing in order to cancel a calf.

ATTENTION Risk of malnutrition if calves do not receive any feed. Malnutrition can cause impaired growth and development, increased susceptibility to illness or even the death of your calves. Tell the end user that he/she must provide the canceled calves with feed using an alternative method.

Note: If you have chosen the value **All** or **Available** for the **automatic registration mode**, you should remove unregistered calves from the pen, since otherwise they will be automatically registered again.

6.3.3.2 Registering a group

You cancel a group as follows:

1. Choose  > **Animal management** > **Cancel** to go to the **Group** submenu.
2. Select the desired group.
3. In **Registered**, you can see how many calves are being fed according to a certain plan.
4. In **Weaned** you can see how many calves have finished the feeding plan and are therefore no longer receiving any feed.
5. Confirm **Cancel** by choosing if all calves in the group are to be cancelled regardless of whether they are registered or weaned calves.
6. Confirm the security prompt **Cancel animals in group?** by choosing .

6.3.3.3 Canceling weaned animals

You cancel weaned calves as follows:

1. Choose  > **Animal management** > **Cancel** to go to the **Weaned animals** submenu.
2. Confirm **cancel?** by choosing if weaned calves are to be canceled.
3. Confirm the security prompt **Cancel animals?** by choosing .

6.3.4 Changing the registration of animals

You can change calves registered at an automatic feeder to another group at any time:

To change registered calf to another group, proceed as follows:

1. Choose  > **Animal management** to go to the **Change registration** submenu.
2. Select the desired calf.

3. Select the desired feeding group in **Group**.
4. Confirm the prompt **Animal xx in group X change registration?** by choosing .

Note: When registration is changed, the feeding day is retained; the calf is **not** reset to the start of the feeding plan (= to plan day 1).

6.4 Cleaning the automatic feeder

You must clean all parts of the automatic feeder that come into contact with liquid or powder animal feed.

Note: If you have installed additional devices such as an additive dispenser, you must also follow the cleaning instructions in the operating manual for these devices.

Cleaning methods

You can use a range of cleaning methods, which you can also combine:

- You can clean some parts, such as the mixer, using programs that run automatically.
- You can clean parts such as the powder container manually.

Remember:

- You must observe all safety warnings in the safety data sheet for the cleaning agent you are using.
- You must always wear the protective gear, such as protective goggles and gloves, specified in the safety data sheet for the cleaning agent you are using.
- Undiluted cleaning agent may not be drained into the ground water or sewage system. Observe the recommendations in the safety data sheet for your cleaning agent and contact your water utility company and your sewage disposal company to find out which regulations apply to you.
- Observe the cleaning intervals recommended by the manufacturer of the cleaning agent as well as those recommended in this operating manual. (see chapter **9.3.1.2** Maintenance intervals and activities, page **127**).
- Only use the cleaning agents recommended in this operating manual.
- Observe the manufacturer's guidelines regarding the amount, temperature and concentration of cleaning agent used.

- Perform all the cleaning steps recommended in this operating manual.

ATTENTION Never use cleaning agents containing chlorine, as they can adversely affect the materials of the automatic feeder and impair its functioning (see chapter **9.2** Automatic feeder material list, page **125**). If this happens, your calves may not receive enough feed. This can lead to malnutrition, which can cause impaired growth and development, increased susceptibility to illness or even the death of your calves.

6.4.1 Cleaning agents

Only use one of the following cleaning agents:

- HyClean K45

You can purchase this cleaning agent from your dealer.

⚠ WARNING **Chemical burns** from cleaning agents. The cleaning agent can cause chemical burns to the eyes or hands. Always wear goggles and protective gloves when using cleaning agents. Follow the safety instructions listed in the safety data sheet for the cleaning agent and use the safety equipment specified.

6.4.2 Preparing for cleaning

6.4.2.1 Cleaning programs that start automatically

⚠ WARNING **Chemical burns** from cleaning agents. The cleaning agent can cause chemical burns to the eyes or hands. Always wear goggles and protective gloves when using cleaning agents. Follow the safety instructions listed in the safety data sheet for the cleaning agent and use the safety equipment specified.

Fill the detergent tank with cleaning agent.

6.4.2.2 Cleaning programs that are started manually

⚠ WARNING **Chemical burns** from cleaning agents. The cleaning agent can cause chemical burns to the eyes or hands. Always wear goggles and protective gloves when using cleaning agents. Follow the safety instructions listed in the safety data sheet for the cleaning agent and use the safety equipment specified.

Prepare for cleaning as follows:

- Measure the necessary amount of cleaning agent. Consult the data sheet for the cleaning agent to determine the quantity recommended by the cleaning agent manufacturer.

- Prepare the cleaning agent next to the automatic feeder.

6.4.2.3 Manual cleaning

- Powder discharge opening.

Have the scraper ready for cleaning the powder discharge opening. The scraper is shipped with the automatic feeder. You can hang it up on the powder discharge.

- Powder container and dosing tongue.

Prepare for cleaning as follows:

1. Turn off the automatic feeder using the control switch and disconnect the mains plug.
2. Empty the powder container.
3. Have a damp cloth ready for cleaning the outside of the automatic feeder.

ATTENTION Damage to the housing of the automatic feeder causes corrosion and impairs its functioning. Never use a pressure washer to clean the automatic feeder.

6.4.3 Cleaning

You perform the following cleaning steps:

- Clean mixer.
- Circuit cleaning.
- Rinse hose.
- Clean powder container and dosing unit.

6.4.3.1 Basic settings

In the **Settings** menu, you define values for the cleaning temperature, detergent amount and teat cleaning.

You define basic settings as follows:

1. Choose  > **Cleaning** > **Settings** to go to the **Temperature** submenu.
2. In **Temperature**, you enter the desired temperature. You can enter values between 10°C and 50°C. The default setting is 45°C.

Note: Consult the data sheet for the cleaning agent to determine the temperature recommended by the cleaning agent manufacturer and enter this value.

3. In **Detergent**, you enter the desired amount of detergent. You can enter values between 0 ml/l and 25 ml/l. The default setting is 0 ml/l.

Note: Consult the data sheet for the cleaning agent to determine the amount recommended by the cleaning agent manufacturer recommends and enter this value.

4. In **Clean teat**, choose   **[yes]** if you want to clean the inside of the teat with rinsing water. The rinsing water is pumped by the suction hoses and drained via the teat. The default setting is **[no]**.

Note: Teat cleaning is important step for preventing infections and should therefore should always be set.

6.4.3.2 Cleaning the mixer

You can clean the mixer automatically (time-controlled) or manually, with or without detergent. A cleaning cycle consists of:

- **Pre-cleaning.**
- **Main cleaning** with the addition of detergent. Depending on the configuration of your automatic feeder, the main cleaning cycle starts automatically or you must start it yourself. When it is started manually, you add the cleaning agent manually during the main cleaning cycle.
- **Rinsing.**

6.4.3.2.1 Cleaning the mixer automatically and time-controlled

If your automatic feeder features a detergent pump or the cleaning package, clean agent is added fully automatically. You must check each day to ensure that the cleaning agent container is full and that the detergent is dispensed into the mixer.

⚠ WARNING **Chemical burns** from cleaning agents. The cleaning agent can cause chemical burns to the eyes or hands. Always wear goggles and protective gloves when using cleaning agents. Follow the safety instructions listed in the safety data sheet for the cleaning agent and use the safety equipment specified.

The rinsing water is not evacuated via the mixer drain valve, if present, but via the teat.

You set automatic mixer cleaning as follows:

Two automatic mixer cleaning cycles at 07:00 hours and 22:00 hours are preset.

- Choose  > **Cleaning** > **Mixer** to go to the **Clean mixer** submenu.

- In **Cleaning/day**, you enter the desired number of cleaning cycles. You can set a maximum of four cleaning cycles.

Note: You should define at least one cleaning cycle per day in order to prevent unhygienic conditions.

- In **Cleaning 1**, you enter the desired time of day.
- Repeat step 3 for additional **cleaning times**.

Note: Start the cleaning at a time when there is little feed entitlement so that your calves do not have to wait too long for feed.

Note: If there is still feed in the mixer jar at the set cleaning time, automatic cleaning is postponed by one hour. After that, any remaining feed is evacuated by the teat and the cleaning cycle is started.

6.4.3.2.1 Manually starting mixer cleaning

You must add the cleaning agent to the mixer manually at the beginning of the main cleaning cycle if your automatic feeder does not have a detergent pump or the cleaning package. The cleaning agent is evacuated automatically.

To prevent unhygienic conditions, perform an automatic cleaning at least 2 times a day without adding cleaning agent, and every other day with manually added cleaning agent.

You start manual mixer cleaning as follows:

1. Choose  > **Cleaning > Mixer** to go to the **Clean mixer** submenu.
2. The message **Detergent** appears in the display.
3. **▲ WARNING** **Chemical burns** from cleaning agents. The cleaning agent can cause chemical burns to the eyes or hands. Always wear goggles and protective gloves when using cleaning agents. Follow the safety instructions listed in the safety data sheet for the cleaning agent and use the safety equipment specified.

Pour the prepared cleaning agent into the mixer.

Confirm the filling by choosing .

Cleaning is started.

Note: Start the cleaning at a time when there is little feed entitlement so that your calves do not have to wait too long for feed.

6.4.3.2.1 Cleaning the mixer jar manually

You must clean the mixer jar manually if it is visibly dirty, if you have disabled automatic cleaning or perform automatic cleaning less than twice a day.

⚠ WARNING Risk of injury caused by automatic startup. The automatic feeder automatically prepares a feed portion when it detects a calf with feed entitlement. The automatically starting stirring blades in the mixing tank can crush or cut off your hand or fingers. Always turn off the automatic feeder with the control switch and disconnect the mains plug before manually cleaning the mixer.

You clean the mixer manually as follows:

1. Press .
2. Confirm **Exit automatic mode?** by choosing .
3. Press  and confirm **Boiler water start?** by choosing .
- The mixer jar is filled with water.
4. Empty the mixer jar. How the mixer jar is emptied depends on the configuration of your automatic feeder.
 - 4.1 Manually pour the contents of the mixer into the drain or gully.
 - 4.2 Confirm **Mixer: empty?** by choosing  if your automatic feeder has a mixer drain valve.
5. Press  and confirm **Boiler water start?** by choosing . Fill two-thirds of the mixer jar with water.
- ⚠ WARNING** **Chemical burns** from cleaning agents. The cleaning agent can cause chemical burns to the eyes or hands. Always wear goggles and protective gloves when using cleaning agents. Follow the safety instructions listed in the safety data sheet for the cleaning agent and use the safety equipment specified.
6. Pour the prepared quantity of cleaning agent into the mixer.
7. Turn off the automatic feeder using the control switch and disconnect the mains plug.
8. Clean the mixer jar with a soft brush or a soft sponge.
9. Empty the mixer jar by tipping out the contents into the drain or gully.

10. Insert the mains plug again and turn on the automatic feeder again using the control switch.

11. Press until the message **Start automatic mode?** appears in your display.

12. Confirm **Start automatic mode?** by choosing .

The automatic feeder is now operating in automatic mode again.

6.4.3.3 Circuit cleaning

With circuit cleaning, you simultaneously clean the suction hoses

Use the mounting holders provided for this procedure.



1 Hose nozzle	4 Suction hose (first station)
2 Cleaning adaptor	5 Suction hose (second station)
3 Rubber closing cap	6 Coupling for milk supply

Run circuit cleaning at least **once a day** if automatic mixer cleaning is not enabled.

Run circuit cleaning at least **once a week** if automatic mixer cleaning is enabled.

You set circuit cleaning as follows:

1. Choose > **Cleaning** to go to the **Circuit cleaning** submenu.
2. In **Water/station**, you enter the desired amount of water. You can enter values from 0.5 l to 1.5 l. The preset default value is 1 l.

Note: The longer the hoses, the higher the value you must select.

3. Confirm **start?** by choosing .

The message **Exit automatic mode?** appears in the display.

4. Confirm **Exit automatic mode?** by choosing .
 5. In **Detergent**, you enter the desired amount of detergent. Use the amount recommended in the data sheet for your cleaning agent.

The automatic feeder starts **Pre-cleaning**. After the mixer has been automatically evacuated, clear instructions are shown in the display. Follow these instructions:

 - 5.1 On all feeding stations, disconnect the suction hoses from the spouts that lead to the teats.
 - 5.2 Position the hoses so that the rinsing water can drain directly into the gully.
 6. Choose to confirm that the instructions have been followed.

The automatic feeder continues the **pre-cleaning**. When pre-cleaning is completed, further instructions appear in the display. Follow these instructions:

 - 6.1 Suspend the suction hoses in the mixer using the mounting holders.
 7. Choose to confirm that the instructions have been followed.

The automatic feeder starts the **main cleaning cycle**. The remaining time appears in the display. When the main cleaning cycle is completed, further instructions appear in the display. Follow these instructions:

 - 7.1 Position the hoses so that the rinsing water can drain directly into the gully.
 8. Choose to confirm that the instructions have been followed.

The automatic feeder starts the **rinsing** cycle.

 - 8.1 Push the suction hoses back onto the hose spouts of the respective teats.
 9. Press until the message **Start automatic mode?** appears in the display.
 10. Confirm **Start automatic mode?** by choosing .
- The automatic feeder is now operating in automatic mode again.

6.4.3.4 Rinsing the hose

The suction hose from the automatic feeder to the teat can be automatically rinsed after each visit by the calf. This improves hygienic conditions by preventing the suction hose from clogging.

If a calf has finished the last portion of its feed entitlement, 0.25 l of warm water is dispensed into the mixer jar. If the calf drinks this warm water, this rinses the suction hose and removes residual milk from it.

Note: Hose rinsing is usually not enabled until the 14th day of the feeding plan because young calves typically do not like to drink water.

You set hose rinsing as follows:

1. Choose  > **Cleaning** to go to the **Hose rinsing** submenu.
2. In **Group**, choose   to select a group (A, B, C or D) from the input field.
3. In **activated**, choose   [**yes**] to enable rinsing and [**no**] to disable rinsing.
4. In **as of plan day**, enter the day on which you want hose rinsing to start. The default setting is 14.

Hose rinsing is now enabled or disabled.

6.4.3.5 Cleaning the powder discharge opening

Check the powder discharge opening for milk powder deposits each day. Remove milk powder deposits immediately. By doing this, you prevent the powder discharge opening from clogging and dispensing insufficient milk powder.

ATTENTION Insufficient milk powder in the feed causes undernourishment or malnutrition in your calves. This can cause impaired growth and development, increased susceptibility to illness or even the death of your calves. Check the powder discharge opening every day.

To clean the powder discharge opening, proceed as follows:

1. Turn off the automatic feeder using the control switch and disconnect the mains plug.
⚠ WARNING Risk of injury caused by automatic startup. Do not reach into the hazardous area of the mixer. The mixer can start up automatically at any time, crushing or cutting off your fingers. Switch off the automatic feeder using the control switch, pull the mains plug and only use the supplied scraper to clean the powder discharge opening.
2. Clean the powder outlet using the supplied scraper. Catch the loosened deposits and milk powder and dispose of them.
3. Reconnect the mains plug.
4. Switch on the automatic feeder again using the control switch.

5. Start automatic mode. Press **Esc** until the message **Start automatic mode?** appears in the display and confirm it by choosing **Enter**.

6.4.3.6 Thorough cleaning of the powder container with the dosing unit

During thorough cleaning of the powder container, milk powder deposits inside the powder container and dosing unit are removed. You must perform a thorough cleaning:

- If you shut down the automatic feeder.
- If the feed that was added is contaminated with germs.

⚠ DANGER Lethal electric shock. The electrical components of the automatic feeder are live. Before opening the powder container, always turn off the automatic feeder using the main switch control switch and disconnect the mains plug.

⚠ WARNING Risk of injury due to automatic start-up. Do not reach into the hazardous area of the powder mixing unit. The powder mixing unit can start up automatically at any time, crushing or cutting off your fingers. Turn off the automatic feeder with the control switch and disconnect the mains plug before reaching into the powder container.

To clean the powder container, proceed as follows:

1. Turn off the automatic feeder using the control switch and disconnect the mains plug.
2. Empty the powder container.
3. Remove the screws that attach the protective grid and remove the protective grid.
4. Clean the protective grid with a damp cloth.
5. Remove the dosing tongue. To do this, remove the star nut located to the right of the powder discharge.
6. Clean the dosing tongue with a damp cloth and then dry the dosing tongue.
7. Use a dry brush and the supplied cleaning scraper to remove the milk powder deposits in the powder container and at the powder discharge opening.
8. Reconnect the dry dosing tongue. Retighten the star nut located to the right of the powder discharge.
9. Reinstall the protective grid. Retighten the screws.

10. Only add milk powder (MP) to the powder container if you want to restart the automatic feeder immediately.
11. Insert the mains plug and turn on the automatic feeder again using the control switch.
12. Enable milk powder dosing in order to fill the dosing star and the dosing unit.
 - 12.1 Go to  > **Diagnosis** to go to the **Powder motor** submenu and press  to start the motor.
13. Calibrate the milk powder (MP) (see chapter **6.7.2.1** Manually recalibrating liquid and powder components, page **98**).

The automatic feeder is now ready for operation again.

6.5 Feeding

You may only use the automatic feeder to prepare liquid feed for your calves.

Note: If you have installed additional peripheral devices such as the additive dispenser, you must also follow the instructions in the operating manual for these devices.

6.5.1 Replenishing feed

To ensure that the automatic feeder can prepare feed, you must make sure that the powder container are always filled.

6.5.1.1 Filling the milk powder container

Only add milk powder (MP) that is suitable for calf feeding.

ATTENTION Make sure that no paper or other foreign objects enter the powder container. The dosing mechanism could otherwise be damaged or the dosage accuracy impaired. As a result, your calves could receive insufficient concentration of feed and would not be supplied with any or enough food. This can lead to malnutrition, which can cause impaired growth or development, increased susceptibility to illness or even the death of your calves.

ATTENTION If the powder hopper is empty, no warning is displayed. Feeder operation is continued without a milk substitute. This can result in your calves only receiving water. This can lead to malnutrition, which can cause impaired growth and development, increased susceptibility to illness or even the death of your calves.

6.5.2 Feed preparation

During preparation of feed, the liquid components (milk or water) are dispensed first. These components are channeled from the to the mixer jar and heated up in the process.

If the mixer jar is filled up to the bar electrode with fluid (water or milk), milk substitute (MP) is dispensed from the powder container into the feed box according to the feeding plan.

6.5.3 Feed distribution

Feed is distributed in **preference mode**.

In preference mode, one animal is always feed after the other. When the calf sucks the feed, the mixed feed in the mixer is conveyed to the sucking teat via the suction hoses and the opened feeding station valve.

6.5.4 Feeding

When you register your calves for the automatic feeder, you assign them to a group (A, B, C or D). Calves in the same group are usually fed according to the feeding plan of their group. See the appendix for examples of default feeding plans (see chapter **9.1.1** Standard feeding plans, page **119**).

You can also choose between rationed feeding and 40FIT feeding.

6.5.4.1 40FIT feeding

A key goal of calf rearing is to ensure that calves get off to the best possible start in life and to prepare them for optimum performance as milk cows later in life. Intensive feeding in the first 40 days of life is an important prerequisite in reaching this goal.

By changing the feeding plan to 40FIT/ rationed, you can activate the 40FIT function in any period. During this period, feed is freely available to calves all day long. The defined feed quantity is only a reference value for calculating alarm levels and is not a limit.

To ensure that the calves do not eat too much, the amount consumed per visit is limited by the defined maximum quantity. In addition, a blocking period can be defined during the 40FIT feeding phase. This means that the calf can only consume the defined maximum quantity during this period. After the subsequent blocking period, the maximum quantity can be consumed again, and the remaining amounts from the previous blocking period are not carried over.

If a feeding period is defined as rationed, the feed quantity to which the calf is entitled is spread across multiple intervals.

The standard A and B feeding plans correspond to the 40FIT feeding concept. The standard C and D feeding plans correspond to the rationed feeding concept.

Note: Contact your feed consultant to find out which feeding plan is best for your calves.

6.5.4.2 Interval feeding program

The feed quantity to which the calf is entitled each day is spread across multiple intervals. (**interval feeding program**). Feed entitlements are saved from interval to interval and can be consumed at any time once a **minimum saved amount**. Without a minimum saved amount, the calves would consume feed portions that are too small. The feed portion is not released until the minimum saved amount defined in the feeding plan has been reached. As a result, the minimum saved amount lets you indirectly define the number of meals that a calf receives. From 8 pm to midnight, a calf can consume the rest of the feed to which it is entitled, even if it has not reach the minimum saved amount. By defining the maximum amount in the plan, you ensure that a calf does not eat too much. You use the **maximum amount** in the feeding program to define how much feed can consume at once. The interval feeding concept is tailored to the needs of your calves. You can set up the feeding plan so that young calves are supplied with several small portions, e.g., 1.5 liters of feed 4 times a day, at the beginning of the feeding period. When the calves get older, you reduce the number of feeding times by increasing the minimum saved amount to 1 feeding time per day. The increasing intervals between the feeding times encourage the consumption of concentrate and roughage. At the same time, you reduce the tendency toward cross-sucking. See the appendix for an example of an interval program (see chapter **9.1.2** Basic principle of interval feeding, page **123**). After consuming its maximum quantity, a calf is excluded from feed distribution for 2 hours, and saved feed quantities are retained.

6.5.4.3 Preferred feeding

You can prefer certain calves for feed consumption. If a preferred calf enters a feeding station, its feed is immediately dispensed. You can prefer calves based on the following criteria:

- Calves that have triggered an **alarm**.
- All calves up to a certain **feeding day**.

- One **box** and all calves that feed there.

You set a preference as follows:

1. Choose  > **Feeding** to go to the **Priority** submenu.
2. In **Alarm** choose   [**yes**] to prefer or [**no**] in order not to prefer calves with alarm messages.
3. In **till feed. day**, enter the feeding day until which you want to prefer a calf.
4. In **Box**, choose   to select the feeding station at which preferred feeding is to take place, or select [**none**].

6.5.4.4 Extra portions

You can manually start the preparation of extra portions at any time. Extra portions are dispensed to a calf in addition to the daily quantity to which it is entitled according to the quantity plan. These portions are not offset against the quantity plan.

You enable dispensing of extra portions as follows:

1. Choose  to go to the **Extra portion** submenu.
2. In **Output**, choose   to select the output location:
 - In **Bucket**, you output the feed portion into a prepared bucket via the gully drain.
 - In **Mixer**, you output the extra portion into the mixer.
 - Transfer the contents of the mixer manually.
 - Confirm **Mixer empty?** by choosing .
 - In **Box X**, you output the extra portion via the selected valve outlet.
 - Select a **feeding station**.
 - Disconnect the hose from the valve outlet
 - Drain the feed into a container suitable for feeding calves.
3. In **Set quantity**, specify the quantity for the extra portion. You can enter values between 0.3 l and 65 l. The default setting is 5 l.

4. In **Temperature**, specify the desired temperature for the extra portion. The temperature may not exceed **45°C**. The default setting is the value that you defined in  > **Device data > Portion > Set temp.**.
5. In **Concentr.**, specify the desired concentration for the extra portion to be mixed. You can enter values between 5 g/l and 255 g/l. The default setting is 150 g/l.
6. Confirm **Start?** by choosing  in order to start dispensing the extra portion.

6.5.5 Checking and changing feeding data for individual animals

In **Animal**, you check and change feeding parameters for individual calves.

6.5.5.1 Group membership

You allocate a registered calf to a group as follows:

1. Choose  > **Feeding > Animal** to go to the **Animal** submenu.
 2. Choose   to select the desired animal number.
 3. In **Group**, choose   to select A, B, C or D.
The prompt **Animal no. in group [A, B, C or D] transfer?** appears.
 4. Confirm the message with .
- The calf is registered in the desired group.

6.5.5.2 Feed quantity

You change the feed quantity of an individual calf as follows:

1. Choose  > **Feeding > Animal** to go to the **Feed** submenu.
2. Choose   to select the desired animal number.
3. Confirm your entry by choosing .
4. In **Deviation**, enter the number of days (validity period) on which the calf is to receive a modified feed quantity. You can enter values between 0 and 99. The default setting is 0 days.
5. In **Quantity**, you enter the additional feed quantity that the selected calf is to receive. You can enter values between 0 and 25 l. The default setting is 0.0 l.
6. In **Plan**, you can check the feed quantity to which the calf is entitled according to the plan.

7. In **Feed**, you can check the feed quantity to which the calf is entitled for the defined period.

After the validity period, your corrections expire and the calf is fed according to the feeding plan of its group again.

6.5.5.3 Feed concentration

You change the feed concentration of an individual calf as follows:

- Choose  > **Feeding** > **Animal** to go to the **Conc.** submenu.
- Choose   to select the desired animal number.
- In **Deviation**, enter the number of days (validity period) on which the calf is to receive a modified feed concentration. You can enter values between 0 and 99. The default setting is 0 days.
- In **Quantity**, you enter the desired change in concentration. You can enter values between 0 g/l and 255 g/l. Use the (+/-) key to enter a minus sign (-) in front of the number, for example -10 g/l, in order to reduce the concentration and a plus sign (+), for example +10 g/l, to increase the concentration. The default setting is 0 g/l.
- In **Plan**, you can check the feed concentration to which the calf is entitled according to the plan.
- In **Concentration**, you can check the feed concentration to which the calf is entitled after the change.

After the validity period, your corrections expire and the calf is fed according to the feeding plan of its group again.

6.5.5.4 Shortening or lengthening total feeding duration

You can shorten or lengthen the total feeding duration for a calf. To do this, you must "push" the animal to the desired plan day.

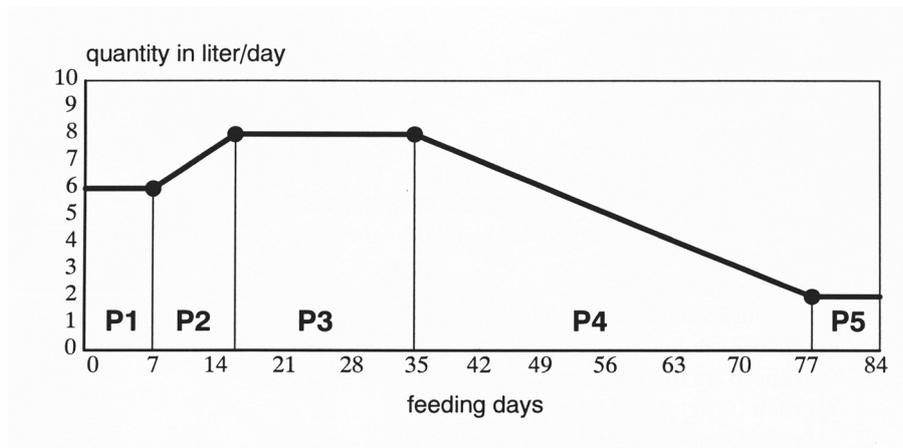

You change the total feeding duration as follows:

1. Choose  > **Feeding** to go to the **Animal** submenu.
2. Choose   to select the desired animal number.
3. In **Plan day**, you can check which day the calf is on in the feeding plan.
4. Confirm **Plan day** by choosing .
5. In **Feed. day**, you can check the number of days that have passed since the calf was registered.
6. In **Correction**, you enter the number of days by which you want to reduce or extend the feeding duration according to the group feeding plan for the calf. The maximum possible extension corresponds to the number of feeding days.

Note: To extend the feeding duration, use the (+/-) key to enter a negative number such as -2. To shorten the feeding duration, use the (+/-) key to enter a positive number such as +2.
7. In **Plan day**, you can check the new plan day of the calf.
8. In **Plan end**, you can view the number of days after which the feeding plan will end.
9. In **Feed**, you can check the feed quantity that the calf will receive on the current day (today).
10. In **Conc.**, you can view the feed concentration that the calf will receive on the current day (today).

6.5.6 Feeding plans

The following plans are taken into account when the feed is prepared:

- Quantity plan
- Concentration plan
- Quantity limitation plan

When you registered your calves for the automatic feeder, you assigned them to a group (A, B, C or D).

For each group, you can assign one of four feeding plans, for example quantity plan A for group A or concentration plan B for group B.

If you are operating an automatic feeder with animal identification, calves from different feeding groups, for example group A and group B, can be housed in the same pen or consume feed at the same box.

Below is an example of a feeding plan.

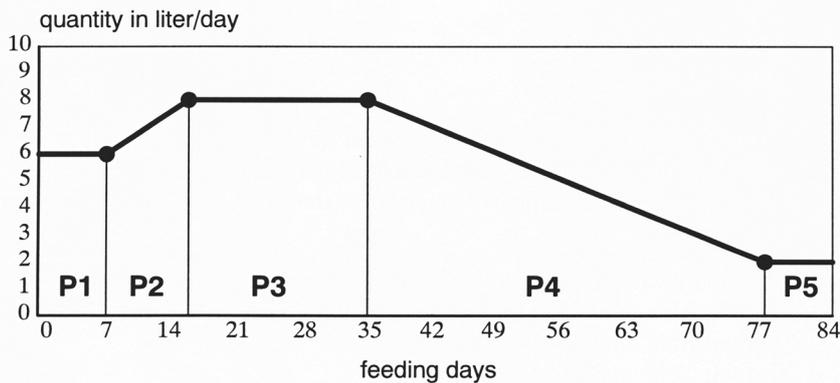

You can divide each feeding plan into up to 5 periods (P 1, P 2, P 3, P 4 and P 5).

The day on which a calf is registered corresponds to the first day of its feeding plan.

Your automatic feeder has preset default plans. You can find the default feeding plans in the appendix of this operating manual (see chapter **9.1.1** Standard feeding plans, page **119**).

These default plans are based on general experience. Only change default plans if, based on your experience in calf rearing and your rigorous monitoring efforts, you are certain that your calves will not suffer from undernourishment or malnutrition. Malnutrition can cause impaired growth or development, increased susceptibility to illness or even the death of your calves.

6.5.6.1 Changing the default quantity plan

You can change the default quantity plan based on 2 feeding concepts: The 40FIT feeding concept (F) or the rationed feeding concept (R).

Depending on the feed entitlement, the feed is distributed across one or more portions. These portions can vary in size. Only the feed amount that is actually consumed is recorded.

ATTENTION If you deviate from a default quantity plan, a calf may not receive sufficient feed. This can lead to malnutrition, which causes impaired growth and development, increased susceptibility to illness or even the death of your calves. Consult your feed consultant before making changes that could have harmful effects.

Proceed as follows to change a default quantity plan based on the 40FIT feeding concept:

1. Choose  > **Feeding > Plans > Feed** to go to the **Quantity** submenu.
2. Choose   to select the desired group.
Groups A and B are assigned to 40FIT plans by default.
The feeding plan of this group is shown in the display.
3. Choose   to select the feeding concept for the group: **40FIT/rationed**
4. In the **Days (P 1)** column, you enter the length of the feeding period. You can enter values from 2 to 99. The default setting is 5 days.
5. In the **from (P 1)** column, you enter the starting value for the feeding quantity. You can select values from 0.1 to 25.5 liters in 0.1 liter increments. The default setting is 6 liters.
Note: The quantity entered here is a reference value for calculating alarm levels and is not a limit.
6. In the **to (P 1)** column, you enter the final value for the feeding quantity. You can select values from 0.1 to 25.5 liters in 0.1 liter increments. The default setting is 6 liters.
Note: The quantity entered here is a reference value for calculating alarm levels and is not a limit.
7. Activate 40FIT feeding at the end of a period by choosing (F).
If necessary, repeat steps 4 to 6 for **P 2** to **P 5**.
8. In **Duration**, you can check the total duration of the feeding plan.

- In **Quantity**, you can check the total feed quantity that a calf will receive according to this plan.

Proceed as follows to change a default quantity plan based on the rationed feeding concept:

- Choose  > **Feeding > Plans > Feed** to go to the **Quantity** submenu.
- Choose   to select the desired group.
Groups C and D are assigned to rationed feeding plans by default.
The default feeding plan of this group is shown in the display.
- Choose   to select the feeding concept for the group.
- In the **Days (P 1)** column, you enter the length of the feeding period. You can enter values from 2 to 99. The default setting is 5 days.
- In the **from (P 1)** column, you enter the starting value for the feeding quantity. You can select values from 0.1 to 25.5 liters in 0.1 liter increments. The default setting is 6 liters.
Note: The quantity entered here is a reference value for calculating alarm levels and is not a limit.
- In the **to (P 1)** column, you enter the final value for the feeding quantity. You can select values from 0.1 to 25.5 liters in 0.1 liter increments. The default setting is 6 liters.
- If necessary, repeat steps 4 to 6 for **P 2** to **P 5**.
- In **Duration**, you can check the total duration of the feeding plan.
- In **Quantity**, you can check the total feed quantity that a calf will receive according to this plan.

6.5.6.2 Changing the default concentration plan

There is a concentration plan for every feeding plan. Just like the feeding plan, the concentration plan can be divided into 5 periods. The default setting is one period, **P 1**. The period length of the quantity plans is, however, not bound to the period length of the feeding plans.

For example, if you want to keep the feed concentration the same for all feeding periods, in **P 1** in the **Days** column, you can enter the same number that is specified for the total number of feeding days in the **Duration** menu item.

The default milk substitute concentration is **150 g/l**. Periods **P 2** to **P 5** are not activated by default.

Note: Many milk powder manufacturers recommend the **MP concentration** (MP = milk substitute) **per liter of feed** on their packing drums. However, the program of the automatic feeder requires you to enter the **MP concentration per liter of water**. To make this conversion easier, use the following conversion table, which is also included in the appendix (see chapter 9.1.3 Milk powder conversion table (MP), page 124).

Desired concentration (in g/l feed)	Setting in concentration plan (in g/l water)	Dry matter (in%/l feed)
100	111	10.0
105	117	10.5
110	124	11.0
115	130	11.5
120	136	12.0
125	143	12.5
130	149	13.0
140	163	14.0
150	176	15.0
160	190	16.0
170	205	17.0
180	220	18.0
190	235	19.0
200	250	20.0

Example: The feed concentration specified on the packaging drum of the milk substitute (MP) is **130 g/l feed**. When you enter the feed concentration plan in your automatic feeder, enter **149 g/l (water)** according to the conversion table.

Desired concentration (in g/l feed)	Setting in concentration plan (in g/l water)	Dry matter (in%/l feed)
125	143	12.5
130	149	13.0
140	163	14.0

ATTENTION If you deviate from the default concentration plan, a calf could receive an insufficient concentration of feed. This can lead to malnutrition, which causes impaired growth and development, increased susceptibility to illness or even the death of your calves. Ensure that the changes will not have any harmful effects, for example by rigorously monitoring your calves.

Calves that receive only milk or milk substitute must be registered in different feeding groups because there is only one default concentration plan per group.

The period length of the concentration plans does not have to match the period length of the quantity plans. If the duration of the concentration plan is shorter than the duration of the quantity plan, a plan over date message appears at the end of the concentration plan in the display of your hand terminal. The concentration of the last feeding portion fed is maintained until the end of the quantity plan.

You change a default concentration plan as follows:

1. Choose  > **Feeding** > **Plans** > **Feed** to go to the **Concentration** submenu.

2. Choose   to select the desired **group** (A, B, C or D).

The default concentration plan of this group is shown in the display.

Note: Unlike for the quantity plan, only P 1 is assigned by default. However, here too, you can activate up to 5 periods (**P 1** to **P 5**). If you activate a period, for example P 2, the following period P3 is automatically visible.

3. In **P 1**, you enter the duration (**Days** column) of the change in concentration and the respective starting value (**from** column) and final value (**to**) of the feed concentration. You can enter values between 5 and 255 g. The default setting is 150 g.

4. If necessary, repeat step 3 for **P 2** to **P 5**.

5. In **Duration**, you can check the total duration of the concentration plan.

6. In **Quantity**, you can check how many kilograms of milk substitute (MP) a calf will receive according to the modified plan.

6.5.6.3 Changing the default quantity limitation plan

In the quantity limitation plan, you use entitlement intervals to define the number of meals (consumption amounts) a calf receives per day.

Note: You can increase or reduce the feed quantity in increments of 0.1 l. Depending on the feed entitlement, the feed is distributed across one or more portions. These portions can vary in size.

To prevent overeating, the amount consumed is limited by the maximum quantity defined in the feeding plan. This means that the calves receive no more than the maximum feeding quantity at each meal.

ATTENTION If you deviate from the default quantity limitation plan, a calf may not receive sufficient feed. You may not reduce the defined quantity limitation values any further, especially

toward the end of the feeding period. This can lead to malnutrition, which causes impaired growth and development, increased susceptibility to illness or even the death of your calves. Ensure that the changes will not have any harmful effects, for example by rigorously monitoring your calves.

You change a default quantity limitation plan as follows:

1. Choose  > **Feeding** > **Plans** > **Feed** to go to the **Limitation** submenu.
2. Choose   to select the desired group (A, B, C or D).
The default quantity limitation plan of this group is shown in the display.
3. In the **Days (P 1)** column, you enter the duration of the change. You can enter values between 1 and 99 days. The default setting is 14 days.
4. In the **Min (P 1)** column, you enter the minimum saved amount in liters. You can enter values between 0.2 and 9.5 liters. The default setting is 2 liters.
5. In the **Max (P 1)** column, you enter the maximum amount in liters. You can enter values between 2.5 and 9.5 liters. The default setting is 2.5 liters.
The cursor goes to the next feeding period (**P 2**).
6. Repeat steps 3 to 5 for **P 2** to **P 5**.
7. In the **Block 40FIT** you enter the amount of time that a calf in the 40FIT period is blocked after consuming its maximum quantity. You can enter values between 00:30 hours and 02:30 hours. The default setting is 02:00 hours.
8. In the **Duration** line, you can check the total duration of the quantity limitation plan in days.

6.5.7 Winter feeding plan

If your automatic feeder features MultiReader identification and a temperature sensor built into the processor card, you can define a winter feeding plan for your calves. You can adjust the feed quantity or concentration so that your calves receive more feed when temperatures drop.

If the ambient temperature rises above a temperature limit that you define, the winter feeding plan is automatically disabled.

Note: The winter feeding plan can only be defined for all calves (regardless of feeding group), not for individual calves.

You set the winter feeding plan as follows:

1. Choose  > **Feeding > Plans** to go to the Winter feeding plan submenu.
2. In the **Active** menu item, you choose   [**yes**] to activate the winter feeding plan and [**no**] to deactivate the winter feeding plan. The default setting is [**no**].
3. In the **Current temp.** menu item, you can check the current temperature.
4. In the **Temp. 3 days** menu item, you can check the average temperature of the last 3 days.
5. In the **Status** menu item, you can check whether a deviation is necessary (**Deviation on**).
6. In the **Limit temp.** menu item, you specify the minimum temperature at which you want feed to be increased.
7. In the **Increase** menu item, you specify the percentage by which you want to increase the feed quantity or feed concentration.

6.5.8 Alarm levels

You use alarm levels to determine the time or value that triggers an alarm. Alarm levels are defined for groups. You can set alarm levels for:

- Feed consumption.
- Drinking speed.
- Feeding break.

You set alarm levels as follows:

- Choose  > **Feeding > Alarm level** to go to the **Feed** submenu.
- Choose   to select the desired group (A, B, C or D).
- In **after**, you enter the amount of time (hours) that can pass after a feed release before an alarm is triggered. The setting applies to the current day. The preset default value is 3 hours. You can enter values from 0 to 9 hours.
- In **as of** (only for 40FIT), you enter the earliest time of day at which an alarm is triggered if the percentage entered for feed consumption is not reached. The setting applies to the current day. The default setting is 12:00 hours and 30%. You can enter values from 08.00 hours to 12.59 hours and 0 to 99%.

- In **yesterday**, you enter the minimum percentage of feed a calf must have consumed yesterday so that no alarm is triggered. The preset default value is 80 %. You can enter values from 0 to 99%.
- In **Dr. speed**, you enter the percentage of drinking speed that a calf must reach so that no alarm is triggered. The preset default value is 70 %. You can enter values from 0 to 99%. The average, specific drinking speed of a calf on the current day (today) is compared to its average drinking speed on the last 3 days. If the entered value is not reached, an alarm is triggered.
- In **break w.o.add.**, you specify how often a calf may interrupt its feed consumption (that is, drink less than its entitled quantity) before an alarm is triggered. The default setting is 3 breaks. You can enter values from 0 to 99.

6.6 Animal control

You can use your automatic feeder for monitoring animals.

Note: You can only obtain information about calves if you operate your automatic feeder with animal identification.

Choose  to go to the menus for animal control. The number next to the submenus shows the number of calves recorded in the respective menu.

6.6.1 Animal list

In the Animal list, you can list your calves in a table sorted by parameters. The table is sorted in ascending order by the first column of the first parameter. This means that the calf with the greatest need for monitoring is at the very top of the table. The following parameters can be displayed:

- Feed consumption
- Drinking speed
- Animal visits
- Breaks

Here is how you define which parameters are displayed in the two columns of the animal list:

1. Choose  > **Device data** to go to the **Animal list** submenu.

2. In **Column 1** or **Column 2**, choose   to select the parameter to be displayed in the respective column.

You call up an animal list as follows:

- Choose  to go to the **Animal list** submenu.
- You can view the following in the top line, from left to right:
 - The number of the calf you have selected in the list. Calves are counted from the top.
 - How many calves are registered.
 - The two parameters you have chosen.
- You can view the following in the subsequent lines, from left to right:
 - The animal number.
 - The plan tendency.
 - The group to which a calf was assigned.
 - The last feeding station visited.
 - Parameter 1. The current value (today) is in the column on the left. Yesterday's value is in the column on the right.
 - Parameter 2. The current value (today) is in the column on the left. Yesterday's value is in the column on the right.

Note: You can directly access the **animal list** by pressing the  key on the 15-key hand terminal.

6.6.2 Entitled

Here you can check the feed entitlement of your calves.

You check feed entitlements as follows:

- Choose  to go to the **Entitlement** submenu.
- From left to right in the top line, you can view the **animal number**, the **plan tendency** and the **feed quantity** scheduled for the current day (today) according to the plan.
- Choose   to select a calf.

- Here you can check whether the select calf is entitled to feed and the amount of feed to which it is still entitled.
 - **Variante 1:** The calf has a feed entitlement. In **as of**, you can check the earliest time of day at which the calf has a feed entitlement and the feed quantity saved until this time.
 - **Variante 2:** The calf has a feed entitlement.
 - **Variante 3:** The calf has more feed saved than it is allowed to consume at one time. You can check the latest time of day at which the calf is blocked after consuming its maximum feed amount.

Note: You can delete the feed block by pressing . Confirm **Delete block?** by choosing .

- **Variante 4:** The calf has saved more feed that it may consume at once and it consumed less than its maximum quantity during its last visit to the feeding station. You can check the latest time of day at which the calf can consume the difference between the consumed quantity and the maximum quantity.
- In **Cons. %**, you can check the percentage of feed that a calf has consumed today (left column) and yesterday (right column).
- In **Cons. L**, you can check the number of liters that a calf has consumed today (left column) and yesterday (right column).
- In **Break**, you can see how often a calf stopped feed consumption today (left column) and yesterday (right column). A calf interrupts feeding if it has consumed less than the quantity to which it is entitled per visit.
- In **Visit**, you can see how often a calf visited the feeding station today (left column) and yesterday (right column).
 - In **Last**, you can view the time of day at which the calf last visited the feeding station.
 - In **With entitlement**, you can see how often a calf visited the feeding station today (left column) and yesterday (right column) with a feed entitlement.
 - In **Without entitlement**, you can see how often a calf visited the feeding station today (left column) and yesterday (right column) without a feed entitlement.

6.6.3 Alarm

You define limit values for parameters that are used for monitoring the feed intake of a calf. If a calf exceeds or falls below these limit values, an alarm is triggered. You can define limit values for the following parameters:

- Feed consumption as percentage of the daily amount.
- Number of feeding breaks.
- Drinking speed.

The procedure is described in detail in chapter **6.5.8 Alarm levels**, page **82**.

You check alarm animals as follows:

- Choose  to go to the **Alarm** submenu.
A table appears in the display.
- From left to right in the top line, you can view the **animal number**, the **plan tendency** and the **feed quantity** scheduled for the current day (today) according to the plan.
- Choose   to select a calf.
- In **Cons. %**, you can check feed consumption for today (left column) and yesterday (right column).
- Confirm **Cons. %** by choosing .
You can view more detailed information about feed consumption for today (left column) and yesterday (right column). You can make changes in the submenus (Feed I and Cons. g/l)
- In **Feed L** you can view and change the feed quantity to which the selected calf is entitled.
The procedure is described in detail in chapter **6.5.5.2 Feed quantity**, page **73**.
- In **Cons. g/l**, you can view and change the feed concentration to which the calf is entitled.
The procedure is described in detail in chapter **6.5.5.3 Feed concentration**, page **74**.

You delete alarms as follows:

- Choose  to go to the **Alarm** submenu.
- Choose   to select a calf.
- Confirm **delete all?** by choosing .

Note: You can only delete alarms from **yesterday**.

6.6.4 Plan over date

One day before an action with a time limit ends, such as an increase in the feed quantity, you will receive a plan over date message for this action. You receive plan date messages if:

- If a calf will not receive any more feed because the feeding plan is ending (**Feed plan**).
- If the concentration plan ends before the feeding plan. Your calves will receive the most recently fed concentration until the end of the feeding plan (**Concentration plan**).
- If deviation plans for feed or concentration are ending. From this point onward, the affected calves are fed according to the feeding or concentration plan of their group.

You check plan over date messages as follows:

- Choose  to go to the **Plan over** submenu.
A table appears in the display.
- From left to right in the top line, you can view the **animal number**, the **plan tendency** and the **feed quantity** scheduled for the current day (today) according to the plan.
- Choose   to select a calf.

You delete plan over date messages as follows:

- Choose  to go to the **Plan over** submenu.
 - Confirm **delete all** by choosing .
- The plan over date message disappears but will appear again the next day.

6.6.5 40FIT

In this menu, you can check how many and which of your calves are in a **40FIT period**.

- Choose  to go to the **40FIT period** submenu.
A table appears in the display.
- From left to right in the top line, you can view the **animal number**, the **plan tendency** and the **feed quantity** scheduled for the current day (today) according to the plan.
- Choose   to select the desired calf.

6.6.6 Marked

In this menu, you can view an overview of the drinking behavior of a calf that you have marked. You can also  mark (see chapter 4.2 Hand terminal, page 30) another calf that you specifically want to monitor.

You view marked animals as follows:

1. Choose  to go to the **Marked** submenu.
A table appears in the display.
2. From left to right in the top line, you can view the **animal number**, the **plan tendency** and the **feed quantity** scheduled for the current day (today) according to the plan.
3. Choose   to select the desired calf.
4. In **Cons. %**, you can view feed consumption for today (left column) and yesterday (right column).
 - Confirm **Cons. %** by choosing .
 - A table appears in the display.
 - In the top line, you can view the **animal number**, the **plan tendency** and the **feed entitlement** for the current day (today).
 - You can view the feed entitlement in liters in the second line. Depending on the feed entitlement, one of the following four variants will appear:
 - **Variant 1:** The calf has a feed entitlement. In **as of**, you can check the earliest time of day at which the calf has a feed entitlement and the feed quantity saved until this time.
 - **Variant 2:** The calf has a feed entitlement.
 - **Variant 3:** The calf has more feed saved than it is allowed to consume at one time. You can check the latest time of day at which the calf is blocked after consuming its maximum feed amount.
 - **Variant 4:** The calf has saved more feed that it may consume at once and it consumed less than its maximum quantity during its last visit to the feeding station. You can check the latest time of day at which the calf can consume the difference between the consumed quantity and the maximum quantity.

- **Note:** You can delete the feed block by pressing . Confirm **Delete block?** by choosing .
 - In **Cons. %**, you can view feed consumption for today (left column) and yesterday (right column) as a percentage.
 - In **Cons. L**, you can view feed consumption for today (left column) and yesterday (right column) in liters
 - **Note:** If you want to set the consumed feed quantity for the current day to zero, press and confirm **Delete consumption?** by choosing .
 - In **Feed l**, you can view the feed quantity in liters to which the calf is entitled today (left column) and yesterday (right column) according to the feeding plan. Here you can change the duration and quantity of deviations in the feed quantity. The procedure is described in detail in chapter **6.5.5.2** Feed quantity, page **73**.
 - In **Cons. g/l**, you can view the feed concentration to which a calf is entitled today (left column) and yesterday (right column) according to the feeding plan. Here you can change the duration and quantity of deviations in the feed concentration. The procedure is described in detail in chapter **6.5.5.3** Feed concentration, page **74**.
5. In **Break**, you can view the number of feeding breaks for today (left column) and yesterday (right column).
6. In **Dr. speed. %**, you can view the drinking speed for today (left column) and yesterday (right column). You can view the relative (%) and the absolute drinking speed (l/min).
- Confirm **Dr. speed. %** by choosing .
 - In **Relative %**, you can view the relative drinking speed as a percentage for today (left column) and yesterday (right column).
 - In **abs. l/min**, you can view the absolute drinking speed in liters for today (left column) and yesterday (right column).
7. In **Visit**, you can view the number of visits to the feeding station for today (left column) and yesterday (right column). You can differentiate between visits with and without feed entitlement.
- Confirm **Visit** by choosing .

- In **Last**, you can view the time of day at which the selected calf last visited the feeding station today (left column) and yesterday (right column).
 - In **With entitlement**, you can see how often a calf visited the feeding station today (left column) and yesterday (right column) with a feed entitlement.
 - In **Without entitlement**, you can see how often a calf visited the feeding station today (left column) and yesterday (right column) without a feed entitlement.
8. In **Feed. day**, you can view the feeding day the calf has reached according to the plan. You can review other detailed information in this menu. The procedure is described in detail in chapter **6.5.5.4 Shortening or lengthening total feeding duration**, page **74**.

6.6.7 New

The **New** menu is used for monitoring newly registered calves. Calves displayed under **New** are registered and can consume feed.

You change the values of newly registered calves as follows:

1. Choose  to go to the **New** submenu.
2. In **Animal no.**, you change the animal number.
3. In **Group**, you register a calf in another group.
4. In **Feed**, you define deviations in the dispensed feed quantity. The procedure is described in detail in chapter **6.5.5.2 Feed quantity**, page **73**.
5. In **Concentration**, you define deviations in the dispensed feed quantity. The procedure is described in detail in chapter **6.5.5.3 Feed concentration**, page **74**.
6. In **Plan day**, you can view and change the planned **feeding days**.
 - In **Plan day**, you can view the plan day that the calf will be on after your correction.
 - In **Plan end**, you can view the number of days in which the end of the plan will be reached.
 - In **Concentration**, you can view the feed concentration that a selected calf will receive today.
7. In **Feed. day**, you can check the number of days that have passed since the calf was registered. Enter a negative value such as -2 in order to extend the total feeding duration by

2 days. Enter a positive value such as +2 in order to shorten the total feeding duration by 2 days.

8. In **Date**, you can view the registration date of a calf.

9. In **Time**, you can view the registration time of a calf.

Proceed as follows to delete a calf from the list of newly registered calves:

- Choose  to go to the **New** submenu.

- Confirm **Confirm?** by choosing .

The calf is deleted from the **New** menu.

Note: This only deletes calves from the **New** menu and not from the feed list. If you forget to confirm, the data will be automatically removed from the **New** menu after two days.

6.6.8 Double

During the fully automated registration process, it is possible for an animal number to be assigned twice. In the **Double** menu, you can adjust the duplicate animal numbers.

Proceed as follows to assign a new animal number to a calf that has been assigned a duplicate animal number:

- Choose  > **Double** to go to the **Animal no.** submenu.

The calf with the duplicate animal no. is displayed in the top line of the table.

- For the displayed calf, select an animal number that has not yet been assigned to a calf.

- Confirm the selected calf by choosing .

- Enter the animal number.

- Confirm **Confirm?** by choosing .

The calf now has its own animal number.

6.6.9 Unknown

If you are operating your automatic feeder with animal identification, the feeder registers all transmitters that approach it. In the **Unknown** menu, the following transmitters are registered:

- Transmitters that have not been assigned an animal number.

- Transmitters that have been assigned a transmitter number but that you have not yet registered for the automatic feeder and assigned to a feeding group.

Proceed as follows to view and register unknown transmitters:

1. Choose  to go to the **Unknown** submenu.
2. Use   to scroll through the list of unknown animal numbers.
3. In **No.**, you can view the unknown animal number.
4. In **Number**, you can see how many unknown transmitters number were identified and how often.
5. In **Time** and **Date**, you can see when the animal identification function last identified the unknown transmitter.
6. In **Register**, you register the calf with the unknown transmitter number for the automatic feeder.
 - Confirm **Register?** by choosing .
 - In **Group**, you choose   to select a group.
 - In **Correct. days**, you enter the number of days by which you want to move the calf in the plan.
 - Confirm **Register?** by choosing .
 - The calf is registered.

You delete unknown transmitters as follows:

- Choose  to go to the **Unknown** submenu.
 - Confirm **Delete?** by choosing .
- The unknown transmitter is deleted.

6.6.10 All

Here you can obtain a full overview of the drinking behavior of all calves. You display this overview in the exact same way as described in the **Plan over** (see chapter 6.6.4 Plan over date, page 87) menu for a single calf. Instead of searching directly for a calf, you use   to scroll through a list of all registered calves.

6.6.11 Total consumption

In this menu, you can view the amount of feed your calves have consumed. You can display the consumption amounts of all calves, individual groups and individual calves as well as the number of quantity of portions dispensed until the present time.

6.6.11.1 Consumption of all calves

You display the consumption of all calves as follows:

1. Choose  > **Animal control** > **Total consumption** to go to the **Total** submenu.
The planned consumption amounts are displayed in the left-hand column (**Set**) and in the right-hand column (**Actual**) the actual consumption amounts of all calves for today, yesterday and the day before yesterday are displayed.
2. Use   to scroll through the list of displayable feed parameters.
3. In **MP**, you can view the amount of milk powder (MP) in kilograms that your calves have consumed today (**t.kg**), yesterday (**y.kg**) and the day before yesterday (**b.kg**).

6.6.11.2 Consumption of individual calves

You display the consumption of all calves as follows:

1. Choose  > **Animal control** > **Total consumption** to go to the **Animal** submenu.
A table is displayed that shows the feed consumption of the selected calf over the entire feeding period.
2. From left to right in the top line, you can view the **animal number**, the **plan tendency** and the **feed quantity** scheduled for the current day (today) according to the plan.
3. Choose   to select a calf.
4. In **MP**, you can view the amount of milk powder (MP) in kilograms that the selected calf has consumed to date.

6.6.11.3 Prepared feed portions

You display the prepared feed portions of all calves as follows:

- Choose  > **Animal control** > **Total consumption** to go to the **Portion** submenu.
- In **Number**, you can view all prepared feed portions to date.
- In **Quantity**, you can view the number of liters of feed prepared.

6.6.11.4 Consumption of a group

You display the consumption of all calves in a group as follows:

- Choose  > **Animal control** > **Total consumption** to go to the **Group** submenu.
The left-hand column (**today**) shows the quantity of feed consumed today and the right-hand column shows the quantity consumed yesterday (**yest.**) in liters.
- Use   to scroll through the list of displayable groups.
- In **quantity**, you can view the amount of feed in liters that calves in the selected group have consumed today and yesterday.

6.6.12 Print

Here you can print out the animal list or the alarm list. To do this, your automatic feeder must be connected to a printer.

To print:

- Choose  > **Print** to go to the **Alarm list** or **Animal list** submenu.
 - Confirm **Print alarm list?** or **Print animal list?** by choosing .
- The selected list is printed.

6.6.13 Searching for animals

In the menus for animal control, you can search for specific calves, such as calves that you have marked. Marked calves are indicated by an asterisk (*) to the left of the animal number. You can also  mark (see chapter 4.2 Hand terminal, page 30) another calf that you specifically want to monitor.

You search for a specific calf as follows:

- Press .
The animal control menus are displayed.
- Go to the desired submenu.
- Search for the calf. You can search for a calf in two ways:
 - Use   to scroll through the list of calves registered for the automatic feeder until you find the calf.

- Press  and enter the number of the calf in the flashing field. The display goes directly to this calf.

If the animal number has not been assigned, the message **Animal no. not existing** appears.

If the animal number has been assigned, but the calf has not been recorded in the selected menu, the message **Animal is not entitled** appears, for example in the Entitled menu.

Note: You can use the search function  in other menus, for example when you register calves.

6.7 Care and maintenance

This chapter covers regular maintenance and functional testing of the automatic feeder, and to a certain extent, its accessories. These ensure that the required hygienic standards are maintained. Maintenance includes additional measures to preserve hygiene that are not described in the Cleaning chapter, as well as scheduled replacement of wearing parts. Visual and functional testing of components as well as replacement of the suction hose and teat can be carried out by the owner/operator.

Note: Repair work and replacement of wearing parts on or in the automatic feeder, with the exception of the suction hoses and teats, may only be carried out by a service technician.

On a regular basis, you must visually inspect and test the functions of the automatic feeder and its components, clean it to maintain hygiene, calibrate it and replace simple wearing parts such as the suction hose. Depending on the automatic feeder component in question, and depending how you operate your automatic feeder, you must perform inspections and maintenance on a weekly, quarterly and annual basis.

At different intervals, service messages such as RS1 (rule service 1) will appear on the display of your automatic feeder. Contact your dealer and specify the service message you have received so that the dealer can perform the necessary maintenance.

Compliance with these maintenance intervals is the only way to ensure the long life and reliability of your automatic feeder.

The following rule services (RS) have been defined:

- RS1 must be performed every 4 months.
- RS2 must be performed every 12 months.

- RS3 must be performed every 36 months.

Note: For quicker overview, see the care and maintenance schedule in the appendix (see **9.3.1.2 Maintenance intervals and activities on page 127**).

⚠ DANGER Lethal electric shock. The electrical components of the automatic feeder are live. Before working on components, always turn off the automatic feeder with the main switch control switch and disconnect the mains plug.

⚠ WARNING Risk of injury caused by automatic start-up. Do not reach into the hazardous area of the mixer and the powder mixing unit. The mixer or powder mixing unit can start up automatically at any time, crushing or cutting off your hand and fingers. Before reaching into the hazardous area of the mixer or powder mixing unit, always turn off the automatic feeder using the control switch and disconnect the mains plug.

6.7.1 Daily care and maintenance tasks

Perform the following inspections on a daily basis:

- Check the safety devices of the automatic feeder for visible damage. Are the warning signs still legible? Immediately replace any warning signs that are difficult to read or damaged. New warning signs are available from Förster-Technik GmbH.
- Check the automatic feeder and its power and water lines for visible damage. You may not operate the automatic feeder if power and water lines are damaged. In the event of damage, turn off the automatic feeder using the control switch and disconnect the mains plug. Contact your service technician immediately. All repairs must always be performed by a service technician.
- Check the intensive mixer for visible damage.
 - Are the electrodes, temperature sensors and mixer blades damaged? Damaged parts must be immediately replaced by a service technician.
 - Are the mixer blades working? Damaged parts must be immediately replaced by a service technician.
 - Is the mixer housing leaking? A leaky housing must be immediately replaced by a service technician.
 - Is the mixer screen clogged? A clogged screen must be immediately cleaned by a service technician.

- Check the teat and suction hoses for the following:
 - **Leaks and wear.** Immediately replace damaged or leaky teats or hoses. Leaky hoses draw in air, and this impairs the functioning of the automatic feeder. As a result, your calves could receive insufficient concentration of feed and would not be supplied with any or enough food. This can lead to malnutrition, which can cause impaired growth and development, increased susceptibility to illness or even the death of your calves. You can obtain new hoses and teats from your dealer.
 - **Cleanliness.** Clean dirty teats and hoses as described in chapter **6.4.3.3** Circuit cleaning, page **65**.
- **⚠ WARNING Risk of injury** caused by automatic startup. Do not reach into the hazardous area of the mixer. The mixer can start up automatically at any time, crushing or cutting off your hand and your fingers. Turn off the automatic feeder with the control switch and disconnect the mains plug. Only use the supplied scraper for cleaning the powder discharge opening.

Check the powder discharge opening for foreign objects and only use the supplied scraper to remove them. Foreign objects can damage the mixer and the automatic feeder. Foreign objects that enter the feed can injure your calves. (See chapter **6.4.3.5** Cleaning the powder discharge opening, page **67**).

Check the powder discharge opening for milk deposits and only use the supplied scraper to remove them. (See chapter **6.4.3.5** Cleaning the powder discharge opening, page **67**). Milk deposits can cause the milk powder to be incorrectly dispensed. As a result, your calves could receive insufficient concentration of feed and would not be supplied with any or enough food. This can lead to malnutrition, which can cause impaired growth and development, increased susceptibility to illness or even the death of your calves.

6.7.2 Care and maintenance tasks every 4 month

To ensure that your automatic feeder can mix the individual liquid and powder feed components (water and milk substitute (MP) in the proper ratio, it must be recalibrated no later than every 4 months or after each new delivery of milk substitute. If you have not concluded a maintenance agreement for this service, you must recalibrate the feeder yourself. This is the only way to ensure that your calves receive a sufficient amount of properly mixed feed.

ATTENTION If you do not recalibrate your automatic feeder on a regular basis, your calves will receive insufficient or improperly mixed feed. This will cause malnutrition. Malnutrition can

cause impaired growth and development, increased susceptibility to illness or even the death of your calves.

The first calibration is performed by your service technician during the initial startup process.

You must manually recalibrate powder and liquid feed and cleaning agents because the actual quantity will deviate from the set quantity for various reasons, such as fluctuations in water pressure.

Calibration consists of multiple steps:

- The volume of liquid components (water and detergent) is determined.
- The weight of the powder components (milk substitute, additives) is determined.

6.7.2.1 Manually recalibrating liquid and powder components

If your automatic feeder does not have an **automatic calibration scale**, you must provide the following items for the calibration:

- 1 glass cylinder with ml increments (approximately 1 liter capacity).
- 1 scale (weighing accuracy of 1 g).
- 1 container for collecting milk substitute.

6.7.2.1.1 Recalibrating without a calibration scale

You determine the actual value using a scale and glass cylinder and the program prompts you to enter this value using the number keys.

Proceed as follows to calibrate the components without a calibration scale:

1. Choose  > **Calibration** to go to the **Components** submenu.
2. In **MP**, you recalibrate the milk substitute.
 - Confirm **MP** by choosing .
 - In **Set quantity**, you can check the amount of milk substitute (MP) to be dispensed.
 - In **Runtime**, you can check the time in which the automatic feeder will dispense milk powder.
 - In **Date**, you can check when MP was last recalibrated.

- Tilt the empty mixer forward.
 - Hold the container for the milk substitute under the powder discharge.
 - Confirm **start?** by choosing .
 - Confirm **Exit automatic mode?** by choosing . This message is only displayed if your automatic feeder is still in automatic mode.
 - Powder is dispensed.
 - Place the container with the collected milk substitute on the scale.
 - In **Actual**, enter the weight displayed on the scale.
 - Confirm **Confirm value....** by choosing .
 - In **Date**, you enter the current date.
 - Repeat the recalibration in order to check your results.
 - Calibrate further powder components using the same method.
3. In **Water**, you recalibrate water.
- Confirm **Water** by choosing .
4. In **Set quantity**, you can check the amount of water that the automatic feeder will dispense.
- In **Runtime**, you can check the time in which the automatic feeder will dispense water.
 - In **Date**, you can check when water was last recalibrated.
 - Confirm **Start?** by choosing .
 - Confirm **Exit automatic mode?** by choosing . This message is only displayed if your automatic feeder is still in automatic mode.
 - Water is dispensed into the mixer.
 - Tilt the mixer so that the water flows into the glass cylinder. Measure the collected water in millimeters.
 - In **Actual**, enter this measured quantity using the number keys.
 - Confirm **Confirm value....** by choosing .

- In **Date**, you enter the current date.
- Repeat the recalibration in order to check your results.
- Calibrate additional liquid components using the same method.

6.7.2.1.1 Recalibrating using the calibration scale:

The automatic feeder determines the actual value using the built-in automatic calibration scale (additional equipment). You only have to recalibrate the detergent manually.

Proceed as follows to calibrate detergent using the calibration scale:

1. Choose  > **Calibration** to go to the **Components** submenu.
2. In **Detergent**, you recalibrate the cleaning agent.
 - Confirm **Detergent** by choosing .
 - In **Set quantity**, you can check the amount of cleaning agent that the automatic feeder will dispense.
 - In **Runtime**, you can check the time in which the automatic feeder will dispense cleaning agent.
 - In **Date**, you can check when the cleaning agent was last recalibrated.
 - Confirm **Start?** by choosing .
 - Confirm **Exit automatic mode?** by choosing This message is only displayed if your automatic feeder is still operating in automatic mode.
 - Place the calibration box into the mixer jar and confirm the prompt **Calibration box used?** by choosing .
 - Detergent is dispensed into the calibration box.
 - Confirm **Confirm value....** by choosing .
 - In **Date**, you enter the current date.
 - Remove the calibration box from the mixer jar.
 - Repeat the recalibration in order to check your results.

6.7.2.1.1 Replacing hoses and teats

- Replace all feed-conducting hoses that run from the mixer to the feeding stations. This reduces the risk of infection. New hoses are available from your dealer.
- Replace all teats. This reduces the risk of infection. New teats are available from your dealer.

6.7.3 Annual care and maintenance tasks

- Perform a visual functional check of the powder conveyor. The powder conveyor may only be repaired by your service technician.

7 Failures and warnings

When an error occurs during operation of the automatic feeder, the Auto LED on the hand terminal flashes. The error is described in failure or warning messages in the display of your automatic feeder.

You must immediately rectify errors that occur during operation. Unresolved errors, for example during preparation of feed, could cause your calves to suffer from malnutrition.

ATTENTION An interruption in feeder operation means that your calves will not receive any feed. This can lead to malnutrition. Malnutrition can cause impaired growth and development, increased susceptibility to illness or even the death of your calves. You must use an alternative method to supply your calves with feed as long as the automatic feeder is out of service.

You can eliminate some errors yourself. Errors that only a service technician can eliminate are indicated as such.

7.1 Failures

In the event of a **failure**, automatic mode is interrupted and no feed is prepared. Respond immediately to the failure and ensure that your calves are supplied with feed using an alternative method as long as the automatic feeder is out of service.

ATTENTION An interruption in feeder operation means that your calves will not receive any feed. This can lead to malnutrition. Malnutrition can cause impaired growth and development, increased susceptibility to illness or even the death of your calves. You must use an alternative method to supply your calves with feed as long as the automatic feeder is out of service.

7.1.1 CRC error

Failure, CRC error is shown in your display if data records in the memory of the control unit have been destroyed. The following variants can be displayed:

- Check animal.
- Check device data.
- Check plans.
- Check prescriptions.

Feeder operation is interrupted.

ATTENTION An interruption in feeder operation means that your calves will not receive any feed. This can lead to malnutrition. Malnutrition can cause impaired growth and development, increased susceptibility to illness or even the death of your calves. You must use an alternative method to supply your calves with feed as long as feeder operation is interrupted.

If this failure message appears, you must contact your service technician immediately.

7.1.2 Heating

failure heating xx.x °C is shown in your display when the temperature of the boiler water is too low. Feeder operation is interrupted.

ATTENTION An interruption in feeder operation means that your calves will not receive any feed. This can lead to malnutrition. Malnutrition can cause impaired growth and development, increased susceptibility to illness or even the death of your calves. You must use an alternative method to supply your calves with feed as long as the automatic feeder is out of service.

You eliminate the failure as follows:

1. Check whether your calves are consuming feed so quickly that the boiler does not have enough time to heat up the water.
2. Check the temperature of the portion and, if necessary, reduce it via  > **Device data** > **Portion**.

If the failure appears again, you must contact a service technician immediately.

7.1.3 Temperature too high

Failure, temperature too high appears in your display when the water temperature in the boiler is too high. Feeder operation is interrupted until the water in the boiler has cooled to the set maximum temperature. Provide your calves with feed using an alternative method as long as feed operation is interrupted.

ATTENTION An interruption in feeder operation means that your calves will not receive any feed. This can lead to malnutrition. Malnutrition can cause impaired growth and development, increased susceptibility to illness or even the death of your calves. You must use an alternative method to supply your calves with feed as long as the automatic feeder is out of service.

You eliminate the failure as follows:

1. Confirm **Failure, temperature too high** by choosing .

2. In **Boiler water start?** hold down .
3. Drain water from the boiler into the mixer jar until the failure message disappears.
4. Confirm **Mixer: empty?** by choosing .

Check the temperature of the supplied water if the Boiler is charged with preheated water.

If the failure appears again:

- Check the temperature of the inflowing water and reduce it, if necessary. This is especially necessary if you charge the Boiler with preheated water.
- If this failure persists, you must contact your service technician immediately.

7.1.4 Boiler not filled

When you turn on the automatic feeder, the control unit checks whether the boiler is filled with water. If it is not filled, feeder operation is interrupted and the message **Failure, boiler not filled** appears in your display.

ATTENTION An interruption in feeder operation means that your calves will not receive any feed. This can lead to malnutrition. Malnutrition can cause impaired growth and development, increased susceptibility to illness or even the death of your calves. You must use an alternative method to supply your calves with feed as long as the automatic feeder is out of service.

You eliminate the failure as follows:

1. Check the water supply
2. <Compact Powder variant > Press in **Boiler: fill**.
3. Check whether the water jet strikes the bar electrode and the display shows **covered**.
4. In **Boiler water start?**, press .
5. Check whether the shutoff valves and the drain valve are not leaking.
6. **Note:** If liquid flows into the mixer through these valves, the bar electrode cannot be grounded.

If this failure persists, you must contact your service technician immediately.

7.1.5 Water shortage

If the bar electrode is not grounded in the mixer jar when water is being added, a water test is started. If the water test is not successful, then feed preparation and animal identification are switched off. **Failure, water shortage** appears in the display.

ATTENTION An interruption in feeder operation means that your calves will not receive any feed. This can lead to malnutrition. Malnutrition can cause impaired growth and development, increased susceptibility to illness or even the death of your calves. You must use an alternative method to supply your calves with feed as long as the automatic feeder is out of service.

You eliminate the failure as follows:

1. Confirm **Boiler water start?** by choosing .
2. Check whether the water jet strikes the bar electrode.
3. Check the water supply to the automatic feeder.
4. Check whether deposits such as calcium have formed on the electrode.
5. Confirm **Delete failure?** by choosing .

If this failure persists, you must contact your service technician immediately.

7.1.6 Mixer emptying

The failure message **Mixer emptying?** appears if the rinsing water in the mixer cannot be drained. Feeder operation is interrupted.

ATTENTION An interruption in feeder operation means that your calves will not receive any feed. This can lead to malnutrition. Malnutrition can cause impaired growth and development, increased susceptibility to illness or even the death of your calves. You must use an alternative method to supply your calves with feed as long as the automatic feeder is out of service.

You eliminate the failure as follows:

⚠ DANGER Lethal electric shock. The electrical components of the automatic feeder are live. Before working on components, always turn off the automatic feeder with the control switch and disconnect the mains plug.

1. Turn off the automatic feeder with the control switch and disconnect the mains plug.

2. Check all feed-conducting components from the mixer up to the mixer drain valve or from the mixer up to the teat for clogs and remove them.
ATTENTION The hose from the mixer drain valve to the drain shaft may not be lengthened.
3. Reinsert the mains plug and turn on the automatic feeder using the control switch .
4. Check the feeding pump:
 - Confirm **Feeding pump start?** by choosing .
5. Check the mixer drain valve:
 - Confirm **mixer drain: open?** by choosing .
6. Check the bar electrode:
7. Confirm **Bo. water start?** by choosing to fill the mixer with water.
8. In **Mixer emptying?**, confirm by choosing .
9. Confirm **Delete failure?** by choosing if you have eliminated the failure.
10. Remove detergent remnants from feed-conducting components by rinsing them with water.
ATTENTION Detergent remnants that enter the feed can be hazardous to the health of calves. Remove detergent remnants before restarting the automatic feeder.
11. Return to automatic mode.

7.1.7 Heating

If **Failure, heating** appears in your display, contact a service technician immediately. Feeder operation is interrupted.

ATTENTION An interruption in feeder operation means that your calves will not receive any feed. This can lead to malnutrition. Malnutrition can cause impaired growth and development, increased susceptibility to illness or even the death of your calves. You must use an alternative method to supply your calves with feed as long as the automatic feeder is out of service.

7.1.8 Boiler temperature sensor

If **Failure, Temp. sensor, boiler** appears in your display, contact a service technician immediately. Feeder operation is interrupted.

ATTENTION An interruption in feeder operation means that your calves will not receive any feed. This can lead to malnutrition. Malnutrition can cause impaired growth and development, increased susceptibility to illness or even the death of your calves. You must use an alternative method to supply your calves with feed as long as the automatic feeder is out of service.

7.1.9 Calibration

Failure, calibration is shown in your display if the liquid or powder feed components and the detergent are not calibrated. The automatic feeder will not switch to automatic mode until you have calibrated these components. Feeder operation is interrupted.

ATTENTION An interruption in feeder operation means that your calves will not receive any feed. This can lead to malnutrition. Malnutrition can cause impaired growth and development, increased susceptibility to illness or even the death of your calves. You must use an alternative method to supply your calves with feed as long as the automatic feeder is out of service.

You eliminate the failure as follows:

Calibrate the liquid and powder feed components as well as the detergent (see chapter **6.7.2.1** Manually recalibrating liquid and powder components, page **98**).

If this failure persists after calibration, you must contact your service technician immediately.

7.1.10 Box/drain valve

Failure, station/drain valve is shown in your display if a feeding station valve or the mixer drain valve is leaking. The automatic feeder loses water during cleaning. Feeder operation is interrupted.

ATTENTION An interruption in feeder operation means that your calves will not receive any feed. This can lead to malnutrition. Malnutrition can cause impaired growth and development, increased susceptibility to illness or even the death of your calves. You must use an alternative method to supply your calves with feed as long as the automatic feeder is out of service.

You must contact a service technician immediately.

7.1.11 Uncontrolled output

Failure, uncontrol. output appears in your display if an error occurs while dispensing water, milk powder and detergent. Feeder operation is interrupted.

ATTENTION An interruption in feeder operation means that your calves will not receive any feed. This can lead to malnutrition. Malnutrition can cause impaired growth and development, increased susceptibility to illness or even the death of your calves. You must use an alternative method to supply your calves with feed as long as the automatic feeder is out of service.

You eliminate the failure as follows:

Turn off the automatic feeder using the control switch and turn it on again after a few seconds. If this failure message appears again, you must contact your service technician immediately. Refer to the messages shown in the display.

7.2 Warnings

In the case of a **warning**, automatic mode is not interrupted, and feeder operation continues.

7.2.1 Identification

Warning, identification appears in your display if animal identification is not working.

You must contact a service technician immediately.

7.2.2 Mixer emptying

Mixer emptying warning appears if the mixer cannot be drained. For example, this can be because the drain is clogged or the feeding pump is no longer running.

This warning message is always hidden when the bar electrode becomes free.

⚠ DANGER Lethal electric shock. The electrical components of the automatic feeder are live. Before working on components, always turn off the automatic feeder with the control switch and disconnect the mains plug.

You eliminate the failure as follows:

1. Check all feed-conducting components from the mixer up to the mixer drain valve or from the mixer up to the teat for clogs and remove them.

ATTENTION The hose that goes from the mixer drain valve to the drain shaft may not be lengthened.

2. Check the feeding pump.

- Confirm **Mixer emptying warning** by choosing .
- Confirm **Feeding pump: start?** by choosing .

- The mixer is evacuated.
3. Check the mixer drain valve if your automatic feeder has one.
 - Confirm the **Mixer emptying warning** by choosing .
 - Confirm **Mixer drain: open?** by choosing .
 - The mixer is evacuated.
 4. Check the bar electrode.
 - Visually check the bar electrode for deposits.
 5. Fill and drain the mixer.
 - Confirm the **Mixer emptying warning** by choosing .
 6. Confirm **Water bo. start?** by choosing .
 - The mixer fills up with water.
 7. Confirm **Mixer: drain?** by choosing .
 - The mixer is drained.

Once the failure is eliminated, the message **Delete failure?** appears in the display. Confirm **Delete failure?** by choosing .

If this does not correct the error, you must contact a service technician immediately.

7.2.3 Temperature sensor, mixer

The **Temp. sensor, mixer warning** is shown in the display if the temperature sensor in the mixer jar is defective or the temperature of the mixed feed in the mixer jar drops below 0 °C.

You must contact a service technician immediately.

7.2.4 Unknown transmitters

The **Unknown transmitters warning** appears in your display:

- If a transmitter is detected by the identification unit for which no animal number has been assigned.
- If a transmitter number has been allocated to an animal number, but has still not been registered.

You eliminate the failure as follows:

1. Confirm **Unknown transmitters warning** by choosing .
2. In **No.**, you check the unknown transmitter number.
3. In **Number**, you check how many times the unknown transmitter number was identified.
4. In **Time**, you check when the transmitter was last registered by the identification system.
5. Confirm **delete?** by choosing if you want to delete the transmitter number.
6. Confirm **Register** by choosing if you want to allocate the unknown transmitter number to an animal number.

7.2.5 Calibration

The **calibration warning** appears in your display if the last calibration was 120 days ago. You can see which components you have to calibrate.

You eliminate the failure as follows

1. Calibrate all components shown in the display as described in chapter **6.7.2.1** Manually recalibrating liquid and powder components, page **98**.
2. Confirm **delete warning?** by choosing .

Note: If you delete the warning without calibrating, the message will appear again the next day.

7.2.6 Calibration scale

The **calibration scale warning** appears in your display if your calibration scale is not working.

You must contact a service technician immediately.

ATTENTION Risk of malnutrition caused by incorrectly dispensed feed portions. Malnutrition can cause impaired growth and development, increased susceptibility to illness or even the death of your calves. You must ensure that you provide your calves with feed using an alternative method as long as the calibration scale is not working.

7.2.7 Double animal number

Warning, Double animal no. appears in your display if the same number was assigned twice during the fully automated registration process.

You change the double animal number as follows:

1. Confirm **Double animal no. warning** by choosing

The **Double** menu in Animal control appears (see chapter 6.6.8 Double, page 91)
2. In **No.**, you can view the full unknown transmitter number of the duplicate calf.
3. In **Animal no.**, change the automatically assigned number.
4. In **Time** and **Date**, check when the double animal number appeared.
5. Once you have changed the animal number, confirm **confirm?** by choosing .

Note: Your confirmation is not effective and the warning is not deleted until you have deleted the animal number.

7.2.8 Machine capacity

Warning, Machine capacity appears when there is no more storage space available for animal numbers or transmitter numbers.

Confirm **Machine capacity** by choosing in order to view detailed information.

- **only 50 animals poss.** means: No more free animal numbers are available.
- **Transmitter storage full** means: No more storage space available for further transmitter numbers.

You rectify the error as follows:

1. Choose  > **Animal management** > **Transmitters** to go to the **Edit** submenu.
2. Select the transmitter number to be deleted and confirm **Delete** by choosing .

Note: You can only delete transmitter numbers from calves that are not registered (= status: available).

3. Confirm **delete warning?** by choosing .

7.2.9 Database

The **Database warning** appears in your display if there are errors in your database. You must contact a service technician immediately.

7.2.10 Checking the SD card (15-key hand terminal only)

The **Check SD card** warning appears in your display:

- If data is to be saved manually, but no SD card is present.
- If data is to be saved manually, but the SD card is currently write-protected.
- If data is to be saved automatically but the SD card is full.
- If data is to be saved automatically but the SD card is currently write-protected.

7.3 Other failures and messages

7.3.1 Automatic feeder

7.3.1.1 Starting program

The message **High Vxx.xx starting program** appears when the control program of the automatic feeder starts.

Wait until the automatic feeder is ready to operate.

7.3.1.2 Initialization of the feeder

The message **first startup Press enter to start installation** appears in the display in the following cases:

- When the automatic feeder starts for the first time.
- If the computer card must be replaced due to a hardware defect.
- If the battery on the computer card is depleted.

Follow the instructions on the screen. The following steps can be performed in the course of the initialization:

- > Restoration of the last backup (if present).
- > Entry of the language for the user interface.
- > Entry of the current date and time.

7.3.1.3 NXP bootloader

The message **NXP Bootloader waiting for update** appears if the control program has started the NXP bootloader while updating the feeder version.

You must contact a service technician immediately.

7.3.1.4 Bootloader version obsolete

Bootloader version obsolete is shown if the automatic feeder's control program has an obsolete version of the internal bootloader. In this case, the application cannot be started.

You must contact a service technician immediately.

7.3.2 Hand terminal

7.3.2.1 CAN bus off

If a short circuit or electromagnetic discharges negatively affect the CAN cable, the message **terminal Vxx.xx CAN bus off** appears in the display.

You must contact a service technician immediately.

7.3.2.2 CAN bus heavy

The following failures trigger the message **terminal Vxx.xx CAN bus heavy** :

- Short circuit.
- Terminating resistor not set.
- Interruption of the data line.
- CAN cable incorrectly clamped on.
- No connection for automatic feeder control unit.

You must contact a service technician immediately.

7.3.2.3 Waiting

The following failures prevent the hand terminal from initializing:

- The CAN bus address of the terminal is not the same as the one defined in setup of the of the automatic feeder.
- The feeder control is not active.

The message **terminal Vxx.xx waiting** appears.

You eliminate the failures as follows:

1. Start search mode: Press when you switch on the feeder and keep this key pressed.
2. If this message appears again, you must contact your service technician immediately.

7.3.2.4 Searching

When the hand terminal is in search mode, the message **terminal Vxx.xx searching** appears.

You must contact a service technician immediately.

7.3.3 Bootloader

7.3.3.1 Waiting for update

The following failures trigger the message **bootloader Vxx.xx waiting for update**:

- The automatic feeder's control program is not able to run.

Update the program using FlashManagerPlus.

Note: With bootloader version 02.04 and higher, you can also update the program using an SD card.

- The bootloader was (accidentally) activated during switching on.

If the bootloader was accidentally started during the start of the automatic feeder by pressing and holding  , you have to restart the automatic feeder.

7.3.3.2 Flash programming

The message **bootloader Vxx.xx flash programming** appears when the program is updated.

Wait until the update has been completed.

7.3.3.3 Starting program

The message **bootloader Vxx.xx starting program** appears when the bootloader of the automatic feeder starts.

Wait until the program has started.

7.4 Service messages

A service message appears in the automatic feeder display every 4 months. This message indicates the maintenance (rule service) that must be performed. Compliance with these maintenance intervals is the only way to ensure the long life and reliability of your automatic feeder.

The following rule services (RS) have been defined:

- RS1 must be performed every 4 months.
- RS2 must be performed every 12 months.
- RS3 must be performed every 36 months.

8 Disposal

All automatic feeder components, liquids and solids must be disposed of in compliance with the applicable official regulations for proper waste recycling and disposal in your country. If you are not certain which regulations apply to you, ask your service technician and use the Internet or the yellow pages to find out which government agency is responsible for your jurisdiction. Contact the appropriate authorities and find out which regulations apply to you.

Always observe the safety data sheets supplied with some components, liquids and solids.

Before you dispose of the automatic feeder, you must shut it down (see chapter 5.1 Shutdown, page 41).

8.1 Disposing of residual cleaning agent

Dispose of residual cleaning agent. See the cleaning agent manufacturer's technical data sheet for more information on the disposal of the cleaning agent.

⚠ WARNING **Chemical burns** from cleaning agents. The cleaning agent can cause chemical burns to the eyes or hands. Always wear goggles and chemical-proof protective gloves when disposing of cleaning agents. Follow the safety instructions listed in the safety data sheet for the cleaning agent and use the safety equipment specified.

8.2 Disposing of hoses

Dispose of hoses as controlled waste or municipal waste, depending on the material. Read the disposal instructions on the packaging of the hoses, or contact your waste disposal center for instructions.

8.3 Disposing of cables

Dispose of cables as controlled waste or municipal waste, depending on the material. Read the disposal instructions on the packaging of the cables, or contact your waste disposal center for instructions.

8.4 Disposing of the hand terminal

Remove the cable that connects the hand terminal to the automatic feeder. The hand terminal contains electronic components and must therefore be disposed of as controlled waste. Ask your waste disposal company where you can dispose of electronic waste.

8.5 Processor board

The automatic feeder contains a processor board with a battery. You must dispose of this component separately. Ask your waste disposal company where you can dispose of electronic waste.

8.6 Disposing of the automatic feeder

For disposal instructions, contact the appropriate authorities, such as your waste disposal company or local government agency.

See the appendix for an overview of the materials in the automatic feeder.

Dispose of the automatic feeder.

9 Appendix

9.1 Feeding

9.1.1 Standard feeding plans

9.1.1.1 Group A

Standard Feeding Plan Group A

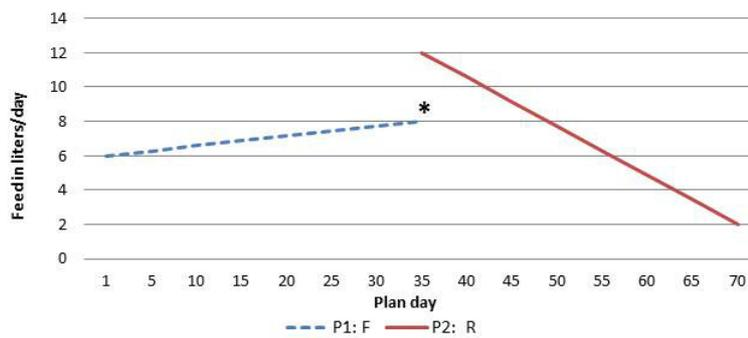

* This quantity is not intended as a maximum quantity but as a reference value to calculate an alarm level.

Standard Feeding Plan

P1: 35 days from 6 to 8 L *F*
 P2: 35 days from 12 to 2 L *R*

Total: 70 days

Standard Concentration Plan

P1: 70 days from 150 to 150 g/L

Standard Quantity Limitation Plan

P1: 10 days: 1.5 L (Min) 2.0 L (Max)
 P2: 25 days: 2.0 L (Min) 2.5 L (Max)
 P3: 35 days: 2.0 L (Min) 3.0 L (Max)

F = 40FIT feeding

R = Restricted feeding

9.1.1.2 Group B

Standard Feeding Plan Group B

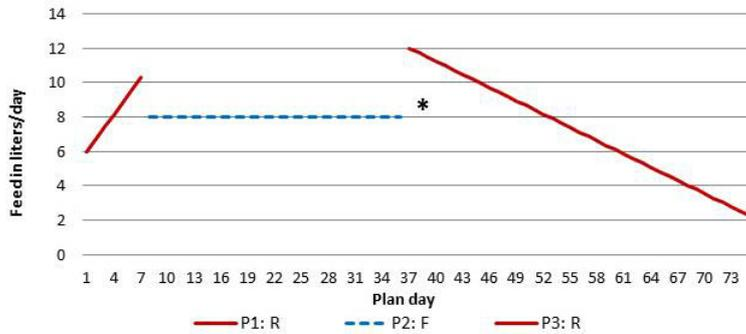

* This quantity is not intended as a maximum quantity but as a reference value to calculate an alarm level.

Standard Feeding Plan

- P1: 7 days from 6 to 10 L **R**
- P2: 28 days from 8 to 8 L **F**
- P3: 40 days from 12 to 2 L **R**

Total: 75 days

Standard Concentration Plan

- P1: 75 days from 150 to 150 g/L

Standard Quantity Limitation Plan

- P1: 10 days: 1.5 L (Min) 2.0 L (Max)
- P2: 25 days: 2.0 L (Min) 2.5 L (Max)
- P3: 40 days: 2.0 L (Min) 3.0 L (Max)

F = 40FIT feeding

R = Restricted feeding

9.1.1.3 Group C

Standard Feeding Plan Group C

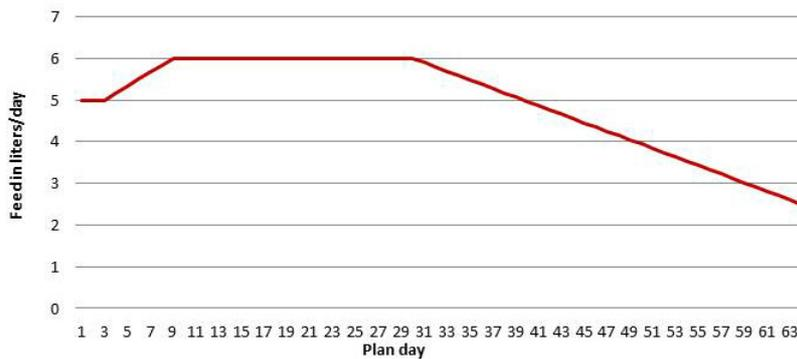

Standard Feeding Plan

- P1: 2 days from 5.0 to 5.0 L
- P2: 6 days from 5.0 to 6.0 L
- P3: 21 days from 6.0 to 6.0 L
- P4: 35 days from 6.0 to 2.5 L

Total: 64 days = 316 L

Standard Concentration Plan

- P1: 64 days from 150 to 150 g/L

Total: 64 days = 47.4 kg MP

Standard Quantity Limitation Plan

- P1: 14 days: 1.5 L (Min) 2.0 L (Max)
- P2: 14 days: 2.0 L (Min) 2.5 L (Max)
- P3: 36 days: 2.5 L (Min) 3.0 L (Max)

9.1.1.4 Group D

Standard Feeding Plan Group D

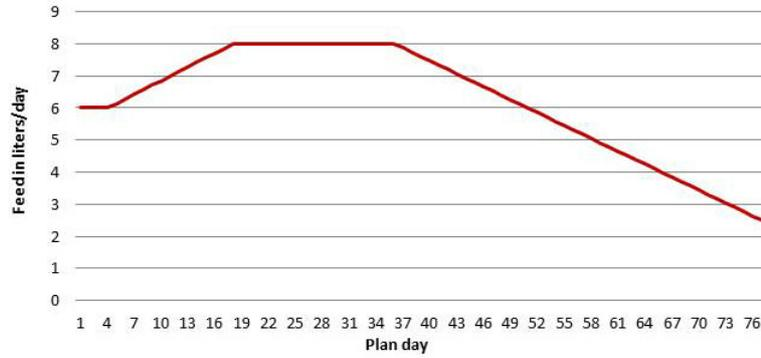
**Standard Feeding Plan**

P1: 3 days from 6.0 to 6.0 L

P2: 14 days from 6.0 to 8.0 L

P3: 18 days from 8.0 to 8.0 L

P4: 42 days from 8.0 to 2.5 L

Total: 77 days = 478 L**Standard Concentration Plan**

P1: 77 days from 150 to 150 g/L

Total: 77 days = 71.7 kg MP**Standard Quantity Limitation Plan**

P1: 14 days: 1.5 L (Min) 2.0 L (Max)

P2: 14 days: 2.0 L (Min) 2.5 L (Max)

P3: 49 days: 2.5 L (Min) 3.0 L (Max)

9.1.1.5 Template for individual feeding plan

Feeding plan

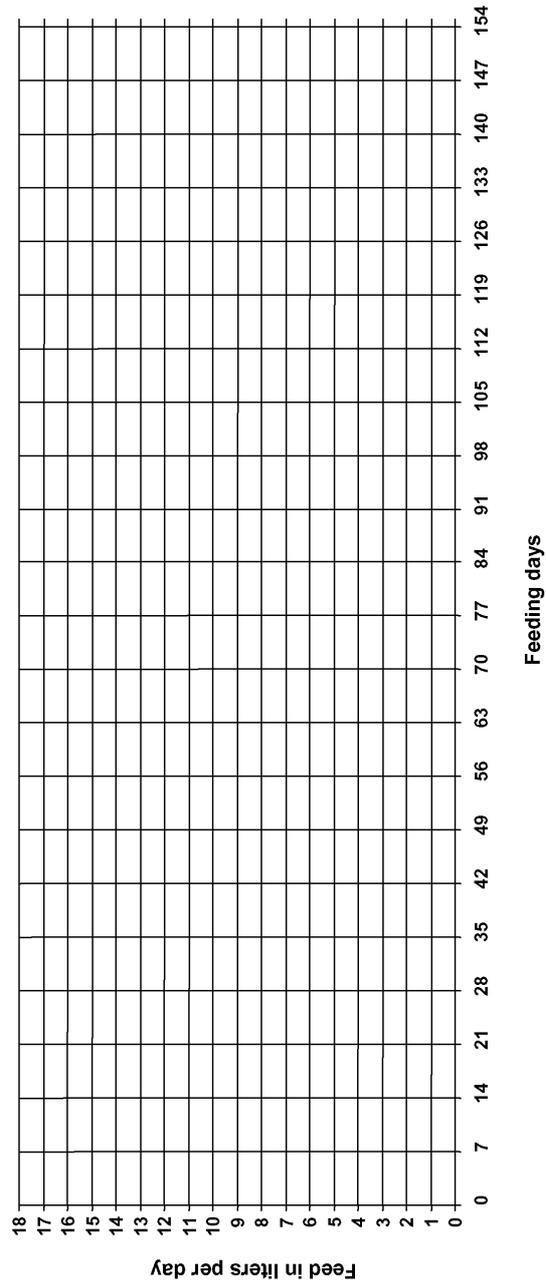

9.1.2 Basic principle of interval feeding

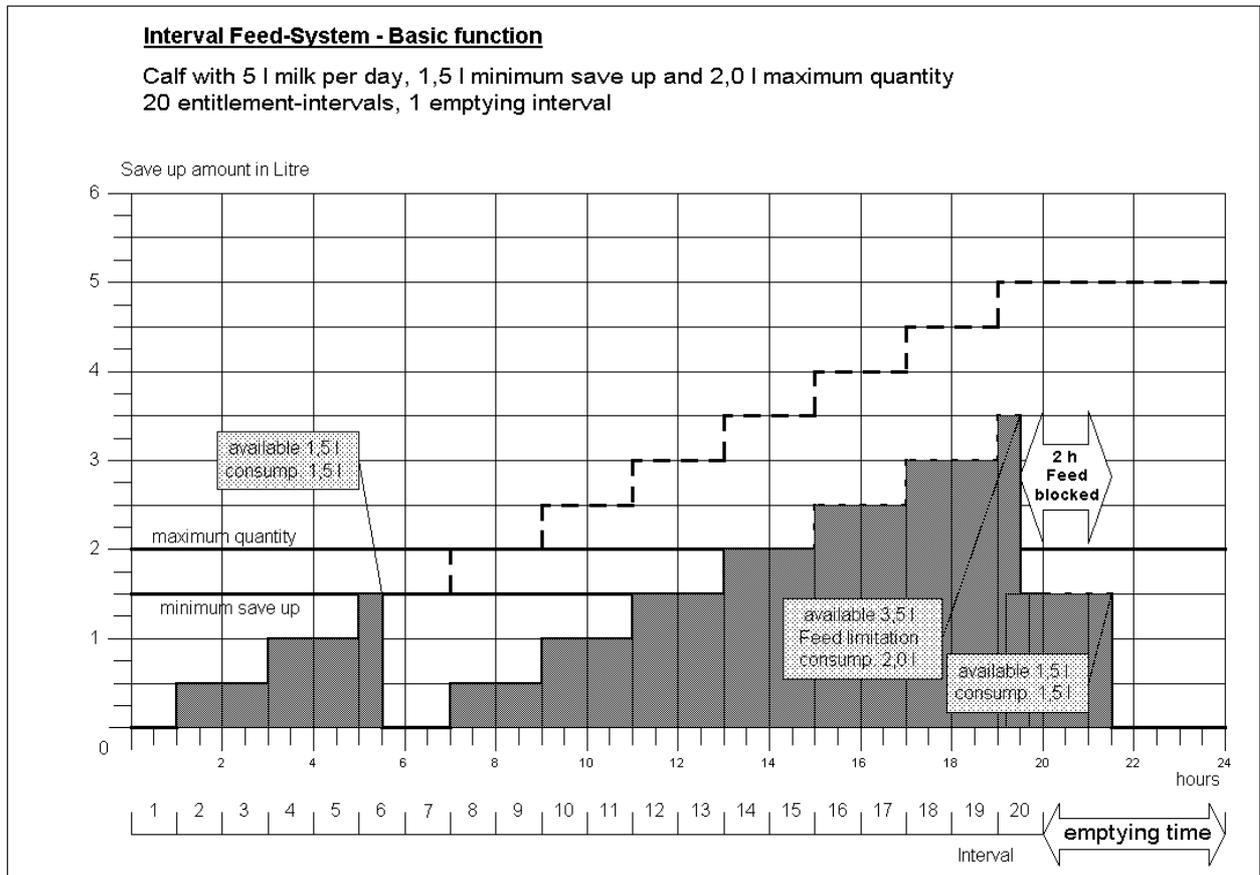

9.1.3 Milk powder conversion table (MP)

Desired concentration (in g/l feed)	Setting in concentration plan (in g/l water)	Dry matter (in%/l feed)
100	111	10.0
105	117	10.5
110	124	11.0
115	130	11.5
120	136	12.0
125	143	12.5
130	149	13.0
140	163	14.0
150	176	15.0
160	190	16.0
170	205	17.0
180	220	18.0
190	235	19.0
200	250	20.0

9.2 Automatic feeder material list

The materials used in the automatic feeder include:

- Brass, Enzidor®
- Silicon carbide
- Carbon
- V2A, V4A
- Plastics: PET, TPE, silicon, PVC, NBR, ABS, PUR
- Viton
- Vulcanized fiber, graphitized
- Rubber
- Bronze

9.3 User maintenance instructions

9.3.1 Care and Maintenance schedule / routine work

Regular maintenance work and functional checks on the automatic feeder and its accessories ensure that the required hygiene standards are maintained. Maintenance includes calibration, cleaning to maintain hygiene beyond the chapter on cleaning, as well as scheduled replacement of wearing parts. Visual and functional testing of components as well as replacement of simple wearing parts, such as the intake hose, can be carried out by the owner/operator.

Note: Repair work and replacement of wearing parts on or in the automatic feeder, with the exception of the intake hoses and teats, may **only** be carried out by a service engineer.

9.3.1.1 Important safety information

⚠ DANGER Danger of death by electric shock. The electrical components of the automatic feeder are live. Turning off using the control switch does not disconnect the voltage to the unit. Always turn off the automatic feeder first using the control switch before carrying out any work on the automatic feeder or its components.

⚠ WARNING Risk of injury due to automatic start-up. The automatic feeder automatically prepares a feeding portion when it detects a calf with feed entitlement. The automatically starting stirring blades in the mixing tank can crush or cut off your hand or fingers. Always turn off the automatic feeder with the control switch and disconnect the mains plug before carrying out any work on the mixer. Only clean the powder discharge opening with the scraper supplied.

⚠ WARNING Risk of injury due to automatic start-up. Do not reach into the hazardous area of the powder mixing unit. The powder mixing unit can start up automatically at any time, crushing or cutting off your fingers. Turn off the automatic feeder with the control switch and disconnect the mains plug before reaching into the powder container.

⚠ WARNING Chemical burns from cleaning agents used. The cleaning agent can cause chemical burns to the eyes or hands. Always wear goggles and protective gloves when using cleaning agents. Follow the safety instructions listed in the safety data sheet for the cleaning agent and use the safety equipment specified.

ATTENTION An interruption or failure in feeding operation means that your calves will not receive any feed. This can lead to malnutrition. Malnutrition can cause impaired growth and development, increased susceptibility to illness or even the death of your calves. You must

provide your calves with feed using an alternative method if the automatic feeder is not working properly or is out of service.

9.3.1.2 Maintenance intervals and activities

Note: If you detect any failures or damage to the automatic feeder between the maintenance intervals recommended below, you must make sure they are remedied immediately by a service engineer as required.

	Care/Maintenance interval			
	Daily	Weekly	4 months	12 months
Inspection of the calves	✓			
Automatic feeder	✓			
<ul style="list-style-type: none"> Visually inspect for damage. 	✓			
Intensive mixer				
<ul style="list-style-type: none"> Visually check correct functioning of electrodes, temperature sensors and mixer blades. 	✓			
<ul style="list-style-type: none"> Visually inspect mixer for leaks. 	✓			
<ul style="list-style-type: none"> Visually check effectiveness of cleaning cycles. 	✓			
<ul style="list-style-type: none"> Visually inspect mixer screen for clogging and clean if necessary. 	✓			
<ul style="list-style-type: none"> Check calibration of detergent. 			✓	
Safety equipment				
<ul style="list-style-type: none"> Check completeness and legibility of safety labels (warning signs). 	✓			
<ul style="list-style-type: none"> Check functioning of scraper for cleaning powder discharge opening. 	✓			
<ul style="list-style-type: none"> Check functioning of protective grid for powder hopper attachment. 	✓			
Water supply				
<ul style="list-style-type: none"> Carry out water calibration. 			✓	
Intake hose and teat				
<ul style="list-style-type: none"> Visually inspect intake hose and teat for damage and wear; clean if necessary. 	✓			
<ul style="list-style-type: none"> Replace all milk hoses from mixer to feeding station. 			✓	
<ul style="list-style-type: none"> Replace the teat. 			✓	

	Care/Maintenance interval			
	Daily	Weekly	4 months	12 months
Shut-off valve/feeding pump <ul style="list-style-type: none"> Open shutoff valve/feeding pump, clean; replace valve membranes with support rings if necessary. 				✓
Powder conveyance <ul style="list-style-type: none"> Check powder discharge opening for foreign bodies. Calibrate, at least for every new MP delivery. Empty powder conveyance and check for correct function. Perform basic cleaning. 	✓		✓	✓ ✓
⊕ Check detergent pump <ul style="list-style-type: none"> Check pressure of hose pump and hoses, and visually inspect intake side of pump for damage and wear; clean if necessary. Replace pump hose. 	✓			✓
Detergent tank <ul style="list-style-type: none"> Check whether detergent tank is filled, top up if necessary. 	✓			

9.4 Automatic feeder shutdown checklist

Shutdown	OK?
1. Run cleaning cycle.	<input type="checkbox"/>
2. Drain water from boiler, solenoid valves, pressure valve, and volume control valve. (In case of frost risk) <ul style="list-style-type: none"> 2.1 Close water tap. 2.2 On hand terminal using  > Water Bo. > Start? Dispense water into feeding box. 2.3 Disconnect water hose between water solenoid valve and boiler. 2.4 Open vent screw on boiler cover and drain boiler. 2.5 Re-attach water hose and tighten vent screw. 	<input type="checkbox"/>
3. Turn off automatic feeder and disconnect mains plug.	<input type="checkbox"/>
4. Disconnect and dispose of water hose.	<input type="checkbox"/>
5. Tip out liquid in mixer.	<input type="checkbox"/>
6. Disconnect and dispose of hose between teat and feed station valve or mixer.	<input type="checkbox"/>
7. Disconnect hose between mixer drain valve, if fitted, and drain channel.	<input type="checkbox"/>
8. Seal cable glands for antennae with dummy plugs.	<input type="checkbox"/>
9. Clean outside of automatic feeder with damp cloth.	<input type="checkbox"/>
10. Empty milk powder container.	<input type="checkbox"/>
11. Remove powder container protective grid.	<input type="checkbox"/>
12. Basic cleaning of milk powder container and dosing unit	<input type="checkbox"/>
13. Store automatic feeder in a dry and frost-free location	<input type="checkbox"/>

9.5 Recommissioning checklist

Note: Before recommissioning the automatic feeder, you must carefully read and observe the operating manual, particularly the safety information.

Important safety information

⚠ DANGER Danger of death by electric shock. The electrical components of the automatic feeder are live. Turning off using the control switch does not disconnect the voltage to the unit. Always turn off the automatic feeder first using the control switch before carrying out any work on the automatic feeder or its components.

⚠ WARNING Risk of injury due to automatic start-up. The automatic feeder automatically prepares a feeding portion when it detects a calf with feed entitlement. The automatically starting stirring blades in the mixing tank can crush or cut off your hand or fingers. Always turn off the automatic feeder with the control switch and disconnect the mains plug before carrying out any work on the mixer. Only clean the powder discharge opening with the scraper supplied.

⚠ WARNING Risk of injury due to automatic start-up. Do not reach into the hazardous area of the powder mixing unit. The powder mixing unit can start up automatically at any time, crushing or cutting off your fingers. Turn off the automatic feeder with the control switch and disconnect the mains plug before reaching into the powder container.

⚠ WARNING Chemical burns from cleaning agents used. The cleaning agent can cause chemical burns to the eyes or hands. Always wear goggles and protective gloves when using cleaning agents. Follow the safety instructions listed in the safety data sheet for the cleaning agent and use the safety equipment specified.

ATTENTION An interruption or failure in feeding operation means that your calves will not receive any feed. This can lead to malnutrition. Malnutrition can cause impaired growth and development, increased susceptibility to illness or even the death of your calves. You must provide your calves with feed using an alternative method if the automatic feeder is not working properly or is out of service.

Recommissioning		OK?
1.	Set up automatic feeder.	<input type="checkbox"/>
2.	Clean outside of automatic feeder with damp cloth.	<input type="checkbox"/>
3.	Fit powder hopper attachment protective grid.	<input type="checkbox"/>
4.	Connect automatic feeder water connection to water tap installed by service engineer using new hose.	<input type="checkbox"/>
5.	Connect teat to feeding station valve (rationed mode) or to feeding box (ad libitum mode) using new hose. (Install hose with downwards gradient to automatic feeder).	<input type="checkbox"/>
6.	Connect mixer drain valve, if fitted, and drain channel using hose. The hose may not be extended.	<input type="checkbox"/>
7.	Connect mains plug to socket installed by service engineer and turn on automatic feeder.	<input type="checkbox"/>
8.	Acknowledge the message failure WT not filled by pressing <input type="button" value="Enter"/> on the hand terminal.	<input type="checkbox"/>
9.	Enter the time and date on the hand terminal using  Device data > Date and time.	<input type="checkbox"/>
10.	Run cleaning programs.	<input type="checkbox"/>
11.	Fill milk powder (MP).	<input type="checkbox"/>
12.	Call a service engineer to set up the automatic feeder.	<input type="checkbox"/>