

Original Service Instructions

Automatic calf feeder
Compact type Powder
Program version 8.00 and higher

TAP5-CH2-25



Table of contents

1	Introduction	7
1.1	Automatic feeder versions	7
1.2	Overview of automatic feeder	8
1.2.1	Front and right side view of automatic feeder	8
1.2.2	Left-hand view of automatic feeder	10
1.2.3	Rear view of automatic feeder	12
1.2.4	Boiler with heating circuit	13
1.3	Technical data	13
1.3.1	Electrical connection	13
1.3.2	Dimensions of the automatic feeder	14
1.3.3	Weight	14
1.3.4	Water connection	14
1.3.5	Boiler	14
1.3.6	Milk powder container	14
1.3.7	Number of feeding stations and animals	15
1.4	Disposal	15
1.5	Symbols and abbreviations	15
1.5.1	Symbols	15
1.5.2	Abbreviations	16
2	Important safety instructions	17
2.1	Necessary qualifications	17
2.2	Hazards arising from the automatic feeder	17
2.2.1	Hazards to health caused by the automatic feeder	17
2.2.2	Material damage caused by the automatic feeder	19
2.3	What hazard warnings are provided?	19
2.3.1	Components of a hazard description	19
2.3.2	Hazards causing death or injury	20
2.3.3	Material damage	20
2.4	Safety labels on the automatic feeder	20
2.4.1	Warning signs on the machine	21
2.5	Safety equipment on the automatic feeder	23
3	Initial startup and restart	27
3.1	Initial startup	27
3.1.1	Setting up the automatic feeder	27
3.1.2	Electrical connection provided by the customer	27
3.1.3	Water connector	28
3.1.4	Installing feeding boxes	29
3.1.5	Connecting aerials	30
3.1.6	Installing the protective grid for the powder hopper attachment	32
3.1.7	Switching on the vapor barrier for powder discharge and frost protection equipment	32
3.1.8	Filling the powder container	33
3.1.9	Switch setting for frost protection equipment and vapor barrier	33
3.1.10	Switching on the automatic feeder	33
3.1.11	Filling the boiler	34
3.1.12	Reinstalling everything	34
3.1.13	Setting the portion	34
3.1.14	Setting operating modes	35
3.1.15	Checking and setting the time/date	35
3.1.16	Draining time box parameters	35

3.1.17	Function keys	35
3.1.18	Animal list	36
3.1.19	Calibrating feed components	36
3.1.20	Checking or setting cleaning settings	36
3.1.21	Cleaning the automatic feeder	36
3.1.22	Reading and creating transmitters	36
3.1.23	Registering animals	37
3.1.24	Entering correction days	37
3.2	Restart process	37
4	Programming and control	39
4.1	Hand terminal	40
4.1.1	The 15-key hand terminal	40
4.1.2	The 12-key hand terminal	43
4.1.3	Auto LED	44
4.2	Offline mode	44
4.3	Automatic mode	44
4.4	Menu structure	45
4.4.1	Symbols	45
4.4.2	Navigation	47
4.4.3	Menus	48
4.5	Device data	50
4.5.1	Operating modes	50
4.5.2	Checking and setting the time/date	51
4.5.3	Setting the portion	52
4.5.4	Draining time box parameters	54
4.5.5	Function keys	55
4.5.6	Animal list	55
4.5.7	Backing up and restoring data	56
4.5.8	New installation	57
4.6	Setup	59
4.6.1	Overview of setup menus	60
4.6.2	Language	61
4.6.3	Time/date	61
4.6.4	Machine	61
4.6.5	Equipment	64
4.6.6	Identification	65
4.6.7	Terminal	65
4.7	Transmitter and animal management	66
4.7.1	Managing transmitters	66
4.7.2	Registering animals	70
4.7.3	Canceling animals or animal groups	73
4.7.4	Changing the registration of animals	74
5	Failures and warnings	77
5.1	Failures and warnings	77
5.1.1	Failures	77
5.1.2	Warnings	86
5.1.3	Other failures and messages	91
5.2	Service messages	94
5.3	Diagnosis	94
5.3.1	Checking valves/motors	95
5.3.2	Checking heater	95
5.3.3	Checking sensors	96
5.3.4	Checking boxes	96

5.3.5	Control	97
5.3.6	Version	98
5.3.7	Setup	99
5.3.8	Software	99
6	Appendix	101
6.1	Checklist for initial startup and restart	101
6.2	Automatic feeder material list	105
6.3	Automatic feeder shutdown checklist	106
6.4	CAN bus addresses	107
6.5	Test components must undergo metrological testing in accordance with national regulations	109

1 Introduction

This operating manual enables you to operate this automatic feeder machine safely as intended.

- > The end user must provide you with the operating manual for the automatic feeder, the operating manuals of all additional equipment to be connected and the safety data sheets for cleaning agents.
- > Carefully read all operating manuals and safety data sheets before starting up the automatic feeder for the first time or restarting it.
- > Observe all of the warnings and safety instructions in these operating manuals and safety data sheets at all times.

1.1 Automatic feeder versions

The following automatic feeder versions are available:

- **Powder** - for the use of milk substitute (MP).
- **Combi** - for the use of milk substitute and fresh milk.
- **Fresh milk** - for the use of fresh milk.

All automatic feeder versions can be equipped with a variety of pieces of peripheral equipment and options.

1.2 Overview of automatic feeder

1.2.1 Front and right side view of automatic feeder

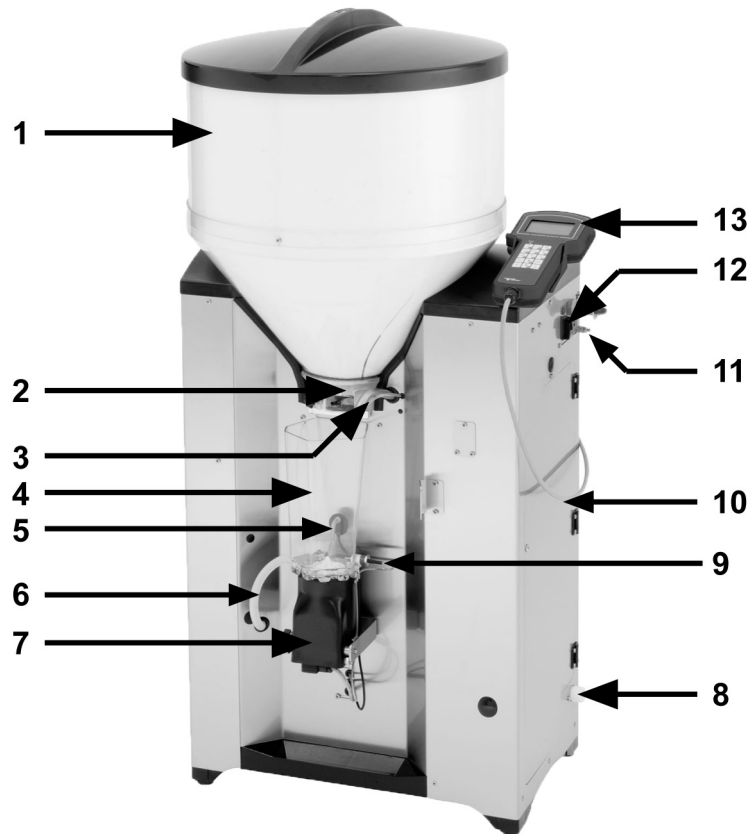

- | | |
|---|--|
| 1 Milk powder container | 8 Water connector |
| 2 Milk powder discharge | 9 Temperature sensor |
| 3 Water supply | 10 Right door |
| 4 Mixing jar | 11 Connection screw for potential equalization |
| 5 Bar electrode | 12 Control switch |
| 6 Hose connection from mixer to box valve | 13 Hand terminal |
| 7 Mixer motor | |

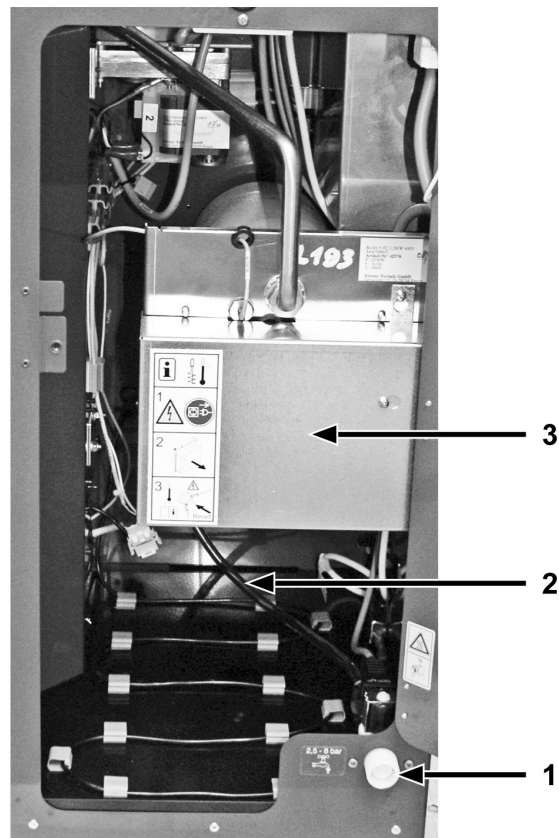
Behind right side door

- 1 Water supply
- 2 Water supply line to boiler container
- 3 Boiler container

1.2.2 Left-hand view of automatic feeder

The name plate is located above the left side door on the outside of the automatic feeder. It contains information about the manufacturer, type and number of the automatic feeder, information for connecting the feeder to the the mains as well as the certifications of the automatic feeder. An example of a name plate is shown below.

Name plate

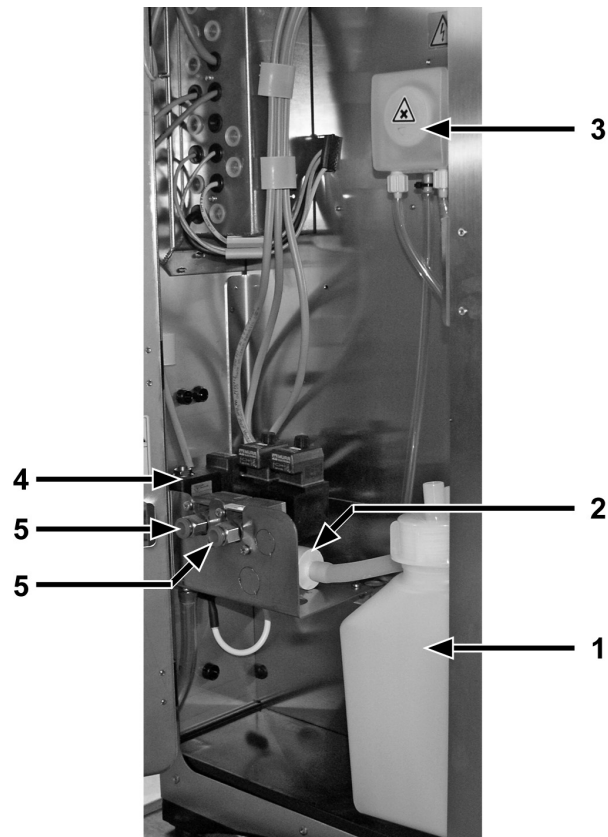

- 1 Name and address of the manufacturer
- 2 Type and number of the automatic feeder
- 3 Information for connection to the mains
- 4 Certifications of the automatic feeder

Behind the left side door

- 1 Storage container for detergent
- 2 Feeding pump
- 3 Detergent dosing pump
- 4 Mixer drain valve
- 5 Feeding box valve(s)

1.2.3 Rear view of automatic feeder

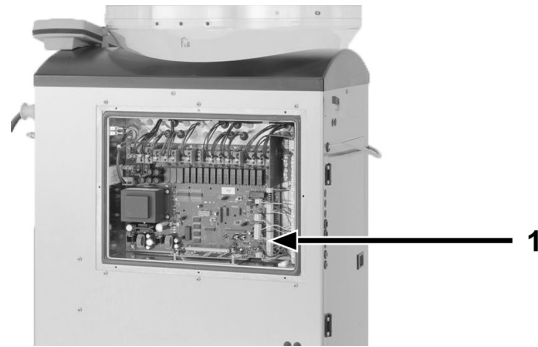

1 Processor and power circuit board

1.2.4 Boiler with heating circuit

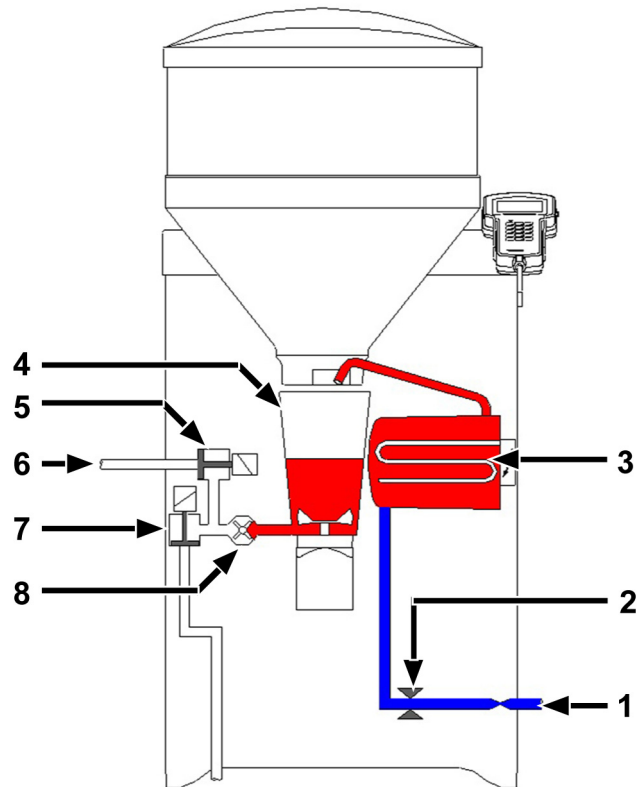

- | | | | |
|---|--------------------------------|---|--|
| 1 | Hose connection for water pipe | 5 | Feeding box valve |
| 2 | Boiler water valve | 6 | Hose connection between feeding box valve and teat |
| 3 | Boiler | 7 | Mixer drain valve (optional) |
| 4 | Mixer | 8 | Feeding pump |

1.3 Technical data

1.3.1 Electrical connection

Note: The electrical connection specifications can be found on the name plate on the left-hand side of the automatic feeder (see **1.2.2** Left-hand view of automatic feeder on page **10**).

1.3.2 Dimensions of the automatic feeder

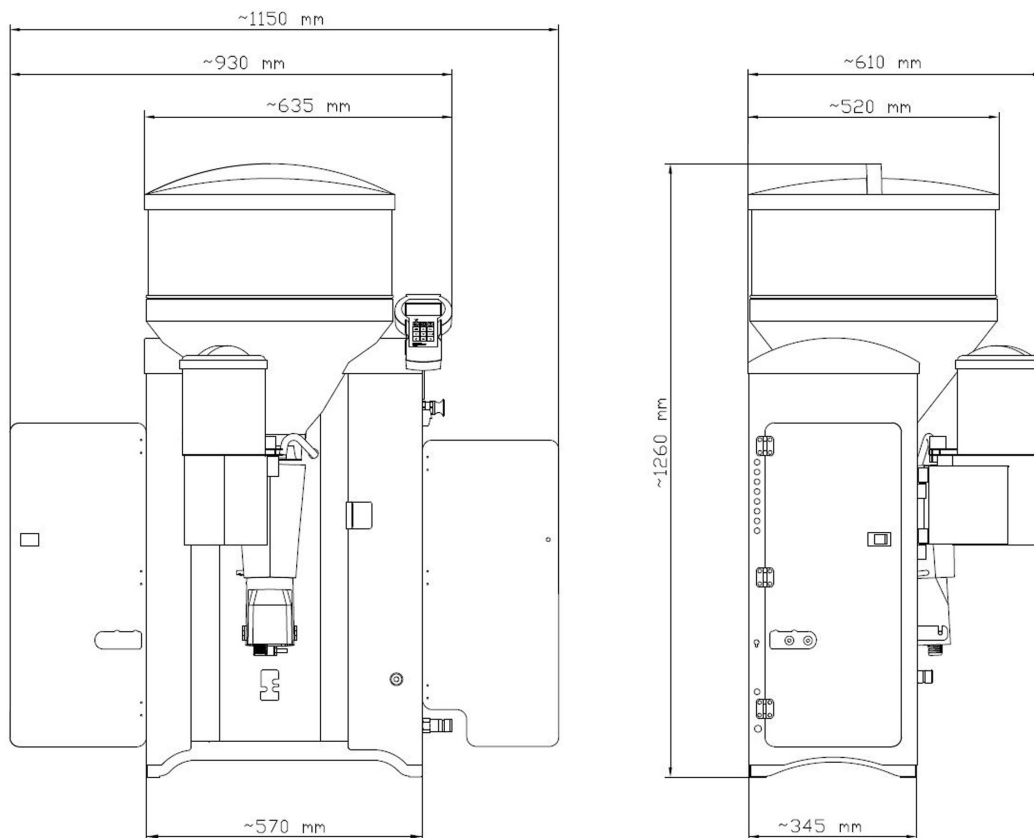

Depth when the fly protection door is opened ~ 690 mm

1.3.3 Weight

Approximately 80 kg.

1.3.4 Water connection

The water connection is made using a 1/2 inch hose with a 3/4 inch screwed connection.

The water pressure to be provided by the customer must be between 2.5 and 6 bar.

1.3.5 Boiler

The boiler holds approximately 7 l of water.

1.3.6 Milk powder container

The milk powder container with attachment holds approximately 35 kg of milk substitute.

1.3.7 Number of feeding stations and animals

Suction stations max. 2	Calves/feeding station max. 25	Calves/device max. 50	Calves/year max. 100
----------------------------	-----------------------------------	--------------------------	-------------------------



1.4 Disposal

All components, liquids and solids must be disposed of in compliance with the official local regulations for waste prevention and appropriate waste recycling or disposal which apply in your country. Also observe the corresponding safety data sheets.

1.5 Symbols and abbreviations

1.5.1 Symbols

You can find a list of the symbols and abbreviations as used in this operating manual in the following.

-  The places in the text marked with this symbol only apply to the automatic feeder Compact.
-  The places in the text marked with this symbol only apply for the automatic feeder Compact+.
-  Option: A white plus sign on a black background indicates that optional functions or equipment are being described.

1.5.2 Abbreviations

Abbreviation	Definition
abs.	absolute
add. disp.	additive dispenser
B-ant.	B-antenna
C	concentrate
C-station	concentrate station
circ. pump	circulation pump
cl. mixer	mixer cleaning
deterg. pump	detergent pump
dos.	dosage
drain. time	draining time
empty v. teat	empty via teat
F-station	feeding station
feed. speed	feeding speed
gr. A (B)	group A (B)
IFS F	intelligent feeding station (feed)
IFS C	intelligent feeding station (concentrate)
IV	interval feeding program
MP	milk powder
MAP	manual training pump
max.	maximum
min. temp.	minimum temperature
mixer drain	mixer draining valve
n.	not
No.	number
powd. motor	powder motor
rel.	relative
servo	servo control
temp.	temperature
train. pump	training pump
w. add.	with additive
w. entit.	with entitled
water bo.	without entitlement
with add.	with additive
w.o. add.	without additive
w.o. entit.	without entitlement

2 Important safety instructions

SAVE THESE INSTRUCTIONS!

This chapter outlines:

- The hazards caused by your automatic feeder and how to avoid them.
- The safety labels attached to the automatic feeder and what they mean.
- How to set up the automatic feeder safely.

The automatic feeder is state of the art and is produced in compliance with recognized safety regulations. However, hazards and adverse effects may arise when using it. Both warning signs directly on the automatic feeder and warning notices in this manual provide warning of these hazards.

2.1 Necessary qualifications

Only trained service technicians are authorized to install the automatic feeder, put it into service and perform maintenance and repairs on it.

Service technicians are specialists with the appropriate qualifications. They are able to assess the work assigned to them and detect potential risks on the basis of their technical training as well as their knowledge of the relevant standards. They are familiar with the relevant accident prevention regulations, generally accepted safety regulations and country-specific standards and provisions.

2.2 Hazards arising from the automatic feeder

2.2.1 Hazards to health caused by the automatic feeder:

⚠ WARNING When using electric appliances, basic precautions should always be followed, including the following:

- The automatic feeder is powered by electricity. You must observe the general precautions for handling electrical equipment:
 - Read all the instructions contained in the operating manual before using the automatic feeder.
 - To prevent the risk of injury, close supervision is necessary when an appliance is used near children.

- Do not touch any moving components of the automatic feeder, for example the mixer blades.
- Only use genuine spare parts from the manufacturer.
- Turn off the automatic feeder and disconnect the mains plug before carrying out any maintenance or cleaning work on the automatic feeder.
- Do not set up the automatic feeder outdoors.
- If connection is made to a potable water system, the system shall be protected against backflow.
- The following specific hazards are associated with the automatic feeder's electrical system:
 - **Electrical breakdown.** If there is an electrical or voltage breakdown, electric current flows through parts of the automatic feeder that are normally insulated. Contact can cause a fatal electric shock. Make sure that a residual current device is installed.
 - **Short circuit, Indirect contact.** If there is a short circuit, current at many times the level of the operating current can flow. Contact can cause a fatal electric shock. Make sure that a residual current device is installed.
- The solenoid valves and the pipes to the valves can reach temperatures of up to 70°C. Contact can cause burns. Do not touch the solenoid valves and pipes during operation.
- Liquid at temperatures of up to 70°C can spray out of the pipes to the valves. This can cause scalding. Do not touch the pipes during operation. Carry out the recommended maintenance on the hoses.
- The mixer and powder supply start up unexpectedly if a calf with feed entitlement approaches. This can crush or chop off fingers or hands. Never reach into the area of the mixer or powder supply while the automatic feeder is in operation. Only use the scraper supplied for cleaning the powder discharge opening.
- **Poisoning.** Additives that are fed to the calves may contain substances that are hazardous to human health. Avoid direct contact and always wear protective gloves and goggles when handling these substances.
- **Chemical burns.** The cleaning agent used for cleaning the automatic feeder contains caustic substances. These can cause severe injuries to the hands or the eyes. Avoid direct con-

tact and always wear chemical-proof protective gloves and goggles when handling the cleaning agent.

- **Excessive strain.** The automatic feeder weighs 80 kg. Never attempt to carry it by yourself as this can cause excessive physical strain.

2.2.2 Material damage caused by the automatic feeder

The automatic feeder can cause the following types of material damage:

- **Infection.** Improper cleaning or incorrect operation can result in calves becoming infected by pathogens from the automatic feeder. This can lead to medical costs or to the death of the calves.
- **Corrosion.** Improper cleaning or maintenance can result in the automatic feeder ceasing to function correctly.
- **Loss of stability.** The automatic feeder must be set up on a level surface. Otherwise, the automatic feeder can tip over and suffer damage.

2.3 What hazard warnings are provided?

Hazards are indicated directly on the automatic feeder by safety labels (warning signs, instruction and prohibition notices), and in the operating manual by specially marked hazard descriptions.

The warnings for hazards that can cause death or injury to people are emphasized more than those for material damage, for example through the colors, hazard words or symbols used.

Safety labels are an important element of the overall automatic feeder safety concept. They provide warnings about hazards and explain how to avoid them.

Make sure that all the specified safety labels are fitted to your automatic feeder and that they are in a legible condition. If the safety labels are difficult to read, replace them immediately. New safety labels are available from Förster-Technik GmbH.

2.3.1 Components of a hazard description



A hazard description is always made up of the following elements:

- The hazard word (Danger, Warning, Caution, Attention).
- The nature of the hazard (what could happen?).

- The location of the hazard (where can it occur?).
- The actions to take to prevent the hazard (what do I need to do?).

2.3.2 Hazards causing death or injury

Depending on their severity and the probability of them occurring, hazards that can cause death or injury to people are indicated by a hazard symbol  (warning triangle with exclamation mark) and the following hazard words:

- The word **Danger** indicates an imminent hazard that will result in death or serious injury.
 - Warning signs on automatic feeder: Danger (white text on red background).
 - Operating manual:  **DANGER** (white text on black background).
- The word **Warning** indicates a potentially hazardous situation that could result in death or serious injury.
 - Warning signs on automatic feeder: Warning (black text on orange background).
 - Operating manual:  **WARNING** (white text on black background).
- The word **Caution** indicates a potentially hazardous situation that could result in minor injury.
 - Warning signs on automatic feeder: Caution (black text on yellow background).
 - Operating manual:  **CAUTION** (white text on black background).

2.3.3 Material damage

The word **Attention** indicates possible material damage. The automatic feeder or an object in its vicinity may be damaged, for example a calf.

- Prohibition signs on the automatic feeder: a pictogram crossed out in red in a white circle with a red border indicates something you are not allowed to do.
- Operating manual: **ATTENTION** (white text on black background).

2.4 Safety labels on the automatic feeder

Different safety labels are attached at the hazardous points on the automatic feeder. Warning signs, prohibition and instruction notices.

What are warning signs?

Warning signs consist of:

- A pictogram in a yellow triangle illustrating the potential hazard.
- Instruction notice.

What are prohibition signs?



Prohibition signs show a pictogram of the prohibited action in a red crossed out circle. See adjacent example. They illustrate what you are not allowed to do. In the example, the crossed out hose means that you are not allowed to use high pressure cleaners.

What are instruction notices?

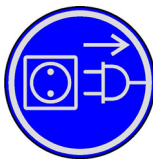

Instruction notices show a pictogram of what you are being instructed to do in a blue circle. They illustrate what you have to do. In the example, the pictogram means that you must always disconnect the plug first.

Other labels

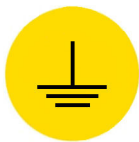

Grounding label. You will see this label at the points where you need to ground the automatic feeder.



Protective earth label. You will see this label adjacent to the main protective earth terminal.

2.4.1 Warning signs on the machine

The following safety signs are attached to the automatic feeder.

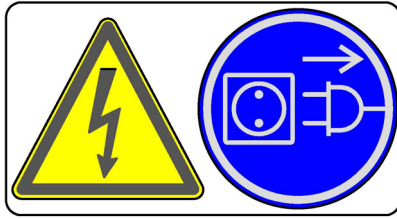
Danger of death by electric shock**Burns / scalding****Health hazards due to additives****Chemical burns caused by cleaning agents**

Automatic startup

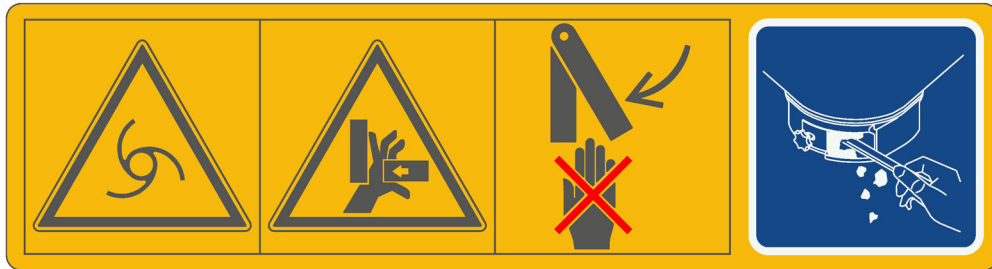

2.5 Safety equipment on the automatic feeder

The automatic feeder may only be operated if the safety equipment is complete and intact. The automatic feeder has the following safety equipment:

- Safety labels (warning signs, instruction and prohibition notices).
- Safety temperature limiter of heater. This shuts down the heater in the event of overheating (temperature rises above 70°C).
- Protective grid for the powder hopper attachment. The protective grid prevents people from being injured by the rotating tools in the hopper, for example when adding milk powder. It must always be installed when the unit is in operation.
- Scraper next to milk powder outlet. The powder discharge opening may only be cleaned with the scraper. This prevents finger and hand injuries caused by the mixer starting up automatically.

The safety devices at the machine are an important part of the safety concept and help prevent accidents.

- Do not remove or change the safety devices without observing the corresponding safety instructions.
- Put the machine into service only after all safety devices have been attached and are in protection position.

Safety temperature limiter

The heater of the automatic feeder is equipped with a safety temperature limiter which is triggered in the event of overheating (70°C) and consequently shuts down the heater.

The safety temperature limiter is triggered if the water gets too hot or if the heater is running dry. It can be found behind the cover illustrated below.

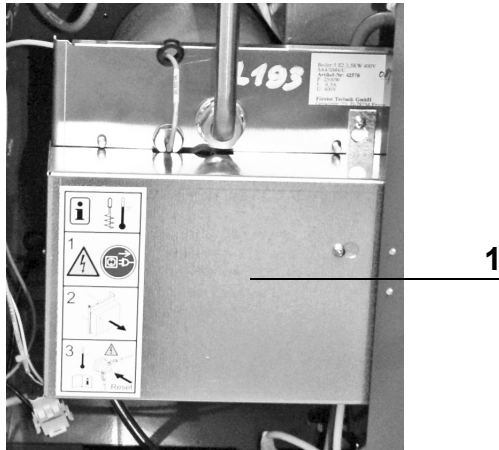

1 Cover of the safety temperature limiter

Protective grid for powder hopper attachment

The protective grid for the powder hopper attachment prevents you from being injured by the rotating tools in the powder hopper, for example, when filling in milk powder.



1 Protective grid

⚠ WARNING Risk of injury caused by rotating tools. The protective grid must always be installed when the unit is in operation.

Scraper next to milk powder outlet

The powder discharge opening may only be cleaned with the scraper. This prevents finger and hand injuries caused by the mixer starting up automatically.

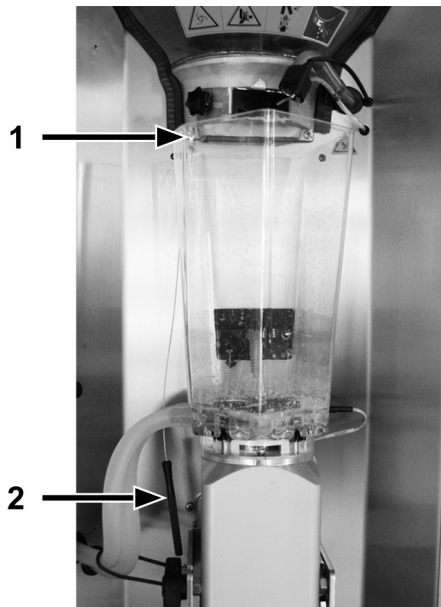

- 1 Mount for scraper
- 2 Scraper

⚠ WARNING Risk of injury caused by automatic startup. Do not reach into the hazardous area of the mixer. This area is indicated by a warning sign. The mixer can start up automatically at any time, crushing or cutting off your fingers. Always turn off the automatic feeder using the control switch and disconnect the mains plug. Only use the scraper supplied for cleaning the powder discharge opening.

SAVE THESE INSTRUCTIONS!

3 Initial startup and restart

Have the end user provide you with the operating manual of the automatic feeder, the separate operating manuals of additional equipment to be connected as well as the safety data sheets for the cleaning agents.

The appendix contains a check list of all instructions that you must observe during the initial startup or restart process. (see **6.1 Checklist for initial startup and restart on page 101**).

3.1 Initial startup

3.1.1 Setting up the automatic feeder

> When setting up the automatic feeder, observe the occupational safety measures.

⚠ CAUTION Health hazards caused by lifting heavy loads Never carry the automatic feeder by yourself.

> Always set up the automatic feeder on an even surface.

> Set up the automatic feeder in a frost-free location. If this is not possible, inform the end user that he/she must protect the automatic feeder from frost using additional equipment such as the additional frost protection equipment or suction hose trace heating system made by Förster-Technik.

> Do not set up the automatic feeder outdoors.

> If connection is made to a potable water system, the system shall be protected against backflow.

> Be sure that the automatic feeder's set-up location has a drain for cleaning water.

> Inform the user that the automatic feeder and its cables must be protected from exposure to sunlight.

3.1.2 Electrical connection provided by the customer

The automatic feeder needs its own power supply.

- The rated voltage and rated frequency must be observed. The supply voltage stated on the left side of the automatic feed must correspond to that of the mains supply.
- A residual current device (30 mA) in the power supply provided by the customer is compulsory for the operation of the automatic feeder.

- Since it is not technically possible to protect the automatic feeder separately against lightning, you must inform the end user that he/she must provide the appropriate lightning protection (e.g. lightning protection system for the entire building).
- Comply with the local regulations and safety measures.

Potential equalization

To protect the animals and prevent electrical failures, provide potential equalization for all metallic objects, such as water pipes, feeding station, stand partition and automatic feeder. These locations are indicated by the grounding label (see **2.4** Safety labels on the automatic feeder on page **20**). The terminal screw for the potential equalization of the automatic feeder is on the right-hand side of the machine housing, directly next to the electrical connection cable. Connect the terminal screw to the local grounding via a short, flexible copper cable (minimum cross-section of 4 mm²).

3.1.3 Water connector

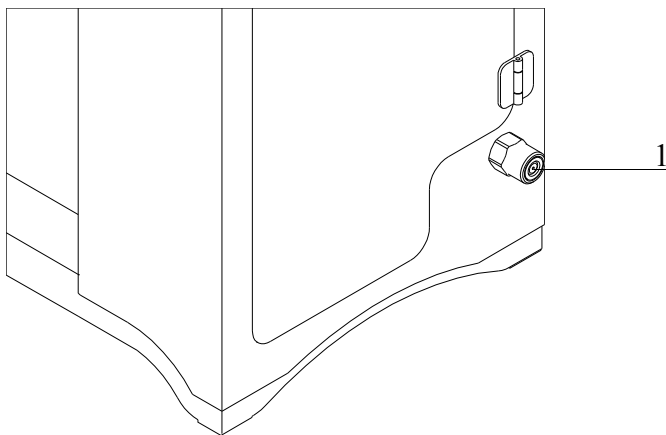

1 Water connector

- > Tell the end user that the supplied water must be of drinking water quality.
- > When connecting the automatic feeders, observe the national regulations about protection of drinking water.
- > Use a separate water shutoff valve for the water supply of the automatic feeder.

- > Make sure the water pressure is consistent. The water pressure must be at least 2.5 bar and may not exceed 6 bar. If the water pressure of 2.5 bar cannot be ensured, you must install a water tank.

Note: If you install a water tank, you must replace the standard water valve of the automatic feeder with a low-pressure valve. As a result, the automatic feeder must always be supplied with water by the water tank.

- > Make sure that the water pipe has a sufficiently large cross section. Determine the number of points where water is simultaneously being extracted and adjust the cross section of the water pipe accordingly.

3.1.4 Installing feeding boxes

3.1.4.1 Installing feeding station

Install the teat at the intended location on the front plate, 10 to 15 cm above the suction hose connection of the mixer and therefore 50 to 80 cm above the calf's platform. The corresponding suction bracket with splash guard has to be pointed downwards.

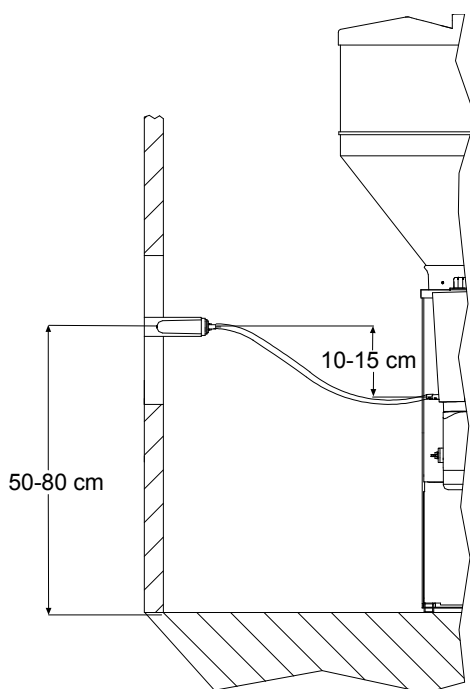

ATTENTION The suction hose may not be longer than two meters. Otherwise, the calves will have problems sucking in the feed. This can lead to malnutrition. Malnutrition can cause impaired growth and development, increased susceptibility to illness or even the death of your calves.

ATTENTION Risk of infection due to feed build-up in hose. The hose between the teat and the feeding box valve (rationed mode) or feeding box (ad lib mode) must not sag and must be installed at a gradient to the automatic feeder (see figure).

ATTENTION Tell end users that the hose between the mixer drain valve and the drain shaft may not be lengthened. Otherwise, the feeding pump will not be able to evacuate the feeding box within the time programmed.

3.1.4.2 Installing stand partition

Install the stand partition in accordance with the manufacturer's instructions.

3.1.5 Connecting aerials

3.1.5.1 Installation of aerials

ATTENTION Risk of damaging aerial cables. Install the aerial cables in such a way that they cannot be damaged by the animals. Observe the separate operating manual for the aerials.

Install the aerials as follows:

- > Keep the distance between the aerial and the transmitter as small as possible, no more than 15 - 25 cm. The range of the aerial is, depending on the version, 15 - 25 cm.
 - If necessary, block the area next to the feeding box. This is the only way to prevent a situation in which feed for a calf is prepared outside the feeding box but that calf does not receive it.

ATTENTION Risk of malnutrition if calves do not receive any feed. Malnutrition can cause impaired growth and development, increased susceptibility to illness or even the death of your calves.

- > Check the range of the aerials using the aerial test (see **5.3.4** Checking boxes on page **96**).

Note: If two calves are identified simultaneously by one aerial, animal identification is interrupted for both calves.

 - The distance between 2 aerials should be approx. 100 cm to avoid any range overlapping.
 - In case double or external identification occurs, shield the aerials using grounded metal plates.

3.1.5.2 Squelch values and identification ranges

The approximate range of the aerials is 15 - 25 cm.

The aerial version is crucial for the identification range. With Nedap micro-identification, you can set the range via the squelch value.

The squelch values and the identification ranges for the various identification systems are listed in the following table. These squelch values are based on experience and are set at the factory.

System	Squelch (default values)	Identification range
Collar (X-responder)	0	15 - 20 cm
Collar (PM-responder)	180	15 - 20 cm
Earmark (also in the collar) (Nedap system)	0	15 - 20 cm
Earmark (also in the collar) (Tiris system)	-	15 - 20 cm

3.1.5.3 Connecting aerial cables to the main board

⚠ DANGER Danger of death by electric shock. The electrical components of the automatic feeder are live. Turning the unit off using the control switch does not disconnect the voltage to the unit. Always turn off the automatic feeder using the control switch and disconnect the mains plug before you connect the aerial cables.

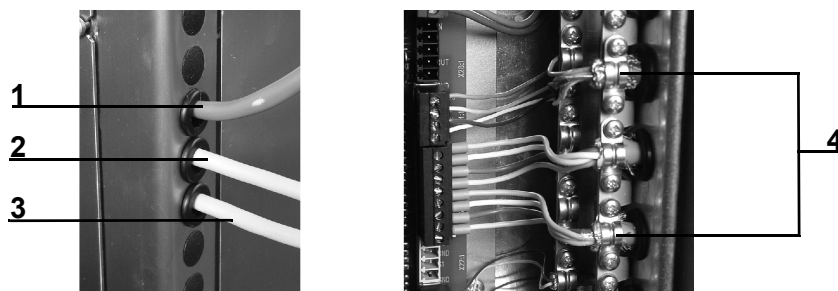

1 Cable of the hand-held terminal	3 Antenna cable of feeding station 2
2 Antenna cable of feeding station 1	4 Cable clamps

Connect the aerial cable as follows:

1. Turn off the automatic feeder using the control switch and disconnect the mains plug.
2. Remove the housing cover from the control box.
3. There are two more cable sleeves under the cable sleeve for the hand terminal cable. Push the aerial cables through them into the control box.
4. Connect the cables of the multi-identification unit or the aerial to the main board in accordance with the wiring diagram. The wiring diagram can be found in the appendix.
5. Fasten the wiring looms to the cable brides.

ATTENTION To ensure grounding, you must also connect a shield of approx. 1 cm. Make sure that the shield lies on the sheath and not on the cable insulation.

6. Connect the control box.
7. Insert the mains plug and turn on the automatic feeder again using the control switch.

3.1.6 Installing the protective grid for the powder hopper attachment**Install the protective grid as follows:**

1. Turn off the automatic feeder using the control switch and disconnect the mains plug.
2. Remove the bag with the small parts and hoses as well as the operating manual from the powder hopper.
3. Insert the protective grid for the powder hopper attachment.
4. Screw in the three self-tapping screws into the holes provided.
5. Insert the mains plug and turn on the automatic feeder again using the control switch.

3.1.7 Switching on the vapor barrier for powder discharge and frost protection equipment

⚠ DANGER Danger of death by electric shock. The electrical components of the automatic feeder are live. Turning the unit off using the control switch does not disconnect the voltage to the unit. Always turn off the automatic feeder using the control switch before you turn on the vapor barrier.

If the automatic feeder is equipped with a vapor barrier for the powder discharge and/or frost protection equipment, you must check whether the respective switches on the processor board are switched on. If not, you must turn on the switch.

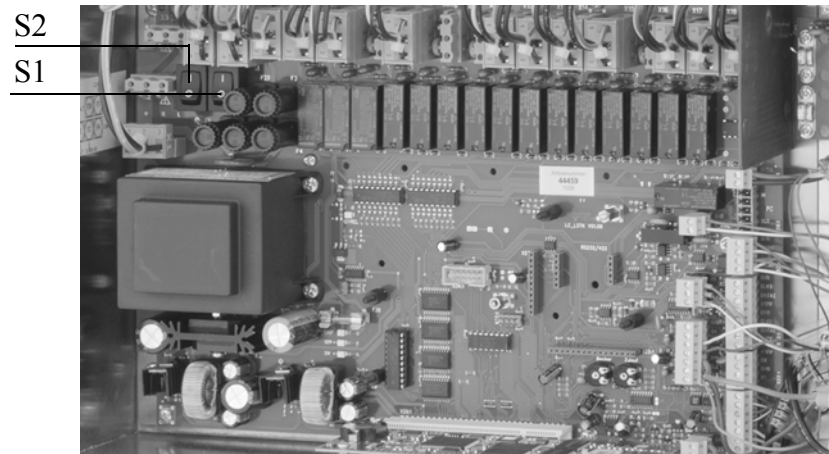

S2 = switch for frost protection equipment
S1 = switch for vapor barrier for powder discharge

3.1.8 Filling the powder container

Fill the powder container with milk powder (MP).

ATTENTION Risk of malnutrition if calves and powder container are empty. Malnutrition can cause impaired growth and development, increased susceptibility to illness or even the death of your calves. Tell the user that he/she must immediately refill an empty powder container or he/she must provide the calves with feed using an alternative method.

3.1.9 Switch setting for frost protection equipment and vapor barrier

Check the switch setting for frost protection equipment and vapor barrier. Set the switch to 0 during summer.

3.1.10 Switching on the automatic feeder

Insert the mains plug and turn on the automatic feeder. Use the hand terminal to control the automatic feeder.

Note: After the hand terminal has been switched on, the program version of the hand terminal first briefly appears in the display, before the automatic feeder carries out a check routine. Do not press any buttons on the control panel during these start routines.

3.1.11 Filling the boiler

1. You can see the failure message in the display **Boiler not filled**. Press .
2. Confirm **Boiler: fill?** with .
3. The boiler is filled with water.

3.1.12 Reinstalling everything

During the initial startup and restart process for the automatic feeder, the program (software) must be completely reinstalled (reset). This will remove superfluous data as well as no longer current or incorrect settings from the memory.

Note: Choosing **New installation** deletes the **animal data** (group membership, barn transfer date, feeding days, consumption sums) because the **transmitter numbers** are set to zero and the **device data** and the **feeding plans** are overwritten with default values.

Reinstall all menus as follows:

1. Choose  > **Device data** to go to the **New installation** submenu.
2. Confirm **Everything** by choosing .
3. Confirm **Reinstall everything?** by choosing .
4. Confirm the security prompt **Do you really want to restore the data to factory settings?** by choosing .

The message **New installation completed!** appears.

5. Confirm **New installation completed!** by choosing .
- All data has been reset to factory settings.

Note: The settings in the feeder setup are not changed by **new installation**.

3.1.13 Setting the portion

ATTENTION Feed temperatures that are too low can cause digestion problems in calves and feed temperatures that are too high can cause gastritis in the abomasum. The temperature of the feed in the feeding box must correspond to the mixing temperature specified by the MP manufacturer. Adhere to the feed temperatures recommended in this operating manual.

In this menu, you make the following settings for the feed portion:

- Set the set temperature of the feed in the feeding box (see **4.5.3.1** Setting the set and minimum temperature on page **52** and following pages).
- Set the minimum temperature of the water in the boiler (see **4.5.3.1** Setting the set and minimum temperature on page **52** and following pages).
- Set the parameters for outlet, for draining and for the mixer's OFF delay (see **4.5.3.2** Mixer draining on page **53** and following pages)

3.1.14 Setting operating modes

Set the **operating modes** of the automatic feeder in the **Device data** menu (see **4.5.1** Operating modes on page **50** following).

The automatic feeder operates in rationed mode by default, but can also be switched to ad lib mode.

3.1.15 Checking and setting the time/date

During the initial startup process, you must check and, if necessary, correct the time and the date. Time and date are shown in automatic mode (see **4.5.2** Checking and setting the time/date on page **51**).



Note: In order to force an immediate daily offset after changing the date, you have to switch the feeder off and then on again.

3.1.16 Draining time box parameters

In the **Feed** menu, you can define the drink-out time for each feeding box. The draining time starts when the bar electrode becomes free for the last portion and ends with the closing of the respective feeding box valve (see **4.5.4** Draining time box parameters on page **54**).

If calves do not finish drinking the contents the feeding box within the standard setting for draining time, the draining time can be extended.



3.1.17 Function keys

The hand terminal has two freely programmable function keys  and . You define which functionality or which menu will be called up when the respective function key is pressed (see **4.5.5** Function keys on page **55**).

3.1.18 Animal list

The animal list is assigned to the  key by default.

Here is how you define which parameters are displayed in the two columns of the animal list:

1. Choose  > **Device data** to go to the **Animal list** submenu.
2. In **Column 1** or **Column 2**, select the parameter by choosing  or . You can choose between **Feed consumption**, **Drinking speed**, **Animal visits**, **Break-offs** and **Consumption**.

3.1.19 Calibrating feed components

You must calibrate the feed components first so that they are mixed in the right proportion. (see section **Operation > Calibration** in the operator's manual for the automatic feeder).

3.1.20 Checking or setting cleaning settings

Check the settings for temperature of the cleaning water, detergent amount and teat cleaning and, if necessary, set them. (see section **Operation > Cleaning** in the operator's manual for the automatic feeder).

3.1.21 Cleaning the automatic feeder

For hygienic reasons, you must completely remove any coolant and lubricant remnants from the system before beginning the initial startup process. To do this, execute the cleaning cycle. (see section **Operation > Cleaning** in the operator's manual for the automatic feeder).

⚠ WARNING Chemical burns caused by cleaning agents used. The cleaning agent can cause chemical burns to the eyes or hands. Always wear goggles and chemical-proof protective gloves when using cleaning agents. Follow the safety instructions listed in the safety data sheet for the cleaning agent and use the safety equipment specified.

3.1.22 Reading and creating transmitters

During the initial startup process for the automatic feeder, the transmitters have to be read and created once in the system. When this is done, each transmitter number is assigned one animal number of no more than six digits. These animal numbers are then available and can be used to register the animals (see **4.7 Transmitter and animal management** on page **66** and the following pages).

3.1.23 Registering animals

Animals are only fed at the feeder if they are also registered for that feeder (see **4.7.2** Registering animals on page **70** and the following pages).

3.1.24 Entering correction days

During the initial startup process, the total feeding duration of an animal can be reduced by “pushing” the animal to the desired plan day. (see section **Operation > Feeding** in the operator's manual for the automatic feeder).

3.2 Restart process

The control units of newly delivered automatic feeders are already put into service by the manufacturer in the factory. After a shutdown, for example after replacing the processor board, you must reinstall the device data.

Proceed as follows:

- Switch on the automatic feeder using the control switch.
- Confirm the message **first startup press enter to start installation** by choosing .
The message **restore last backup?** will appear if there is a valid backup of the animal and device data in the automatic feeder.
- Confirm **restore last backup?** by choosing .
- In **Basic settings**, enter the desired language, the current date and the current time of day.
This concludes the restart process.

4 Programming and control

You control the automatic feeder using the hand terminal. The hand terminal is directly connected to the automatic feeder by a cable. You switch it on and off together with the automatic feeder. It remains in operation as long as the automatic feeder is switched on.

Note: After the hand terminal has been switched on, the program version of the hand terminal first briefly appears in the display, before the automatic feeder carries out a check routine. Do not press any buttons on the control panel during these start routines.

- You monitor and control the automatic feeder directly via the keys of the hand terminal, for example the **feeding pump**.
- You monitor and change the settings of the automatic feeder and the values of calves via menus. The menus and sub-menus are arranged so that you can find the necessary settings quickly and easily. With a click of a button, you can access the most important menus, such as **Animal control**, **Main menu** and **Manual functions**, as well as the **Animal list** using the 15-key hand terminal.

4.1 Hand terminal

4.1.1 The 15-key hand terminal

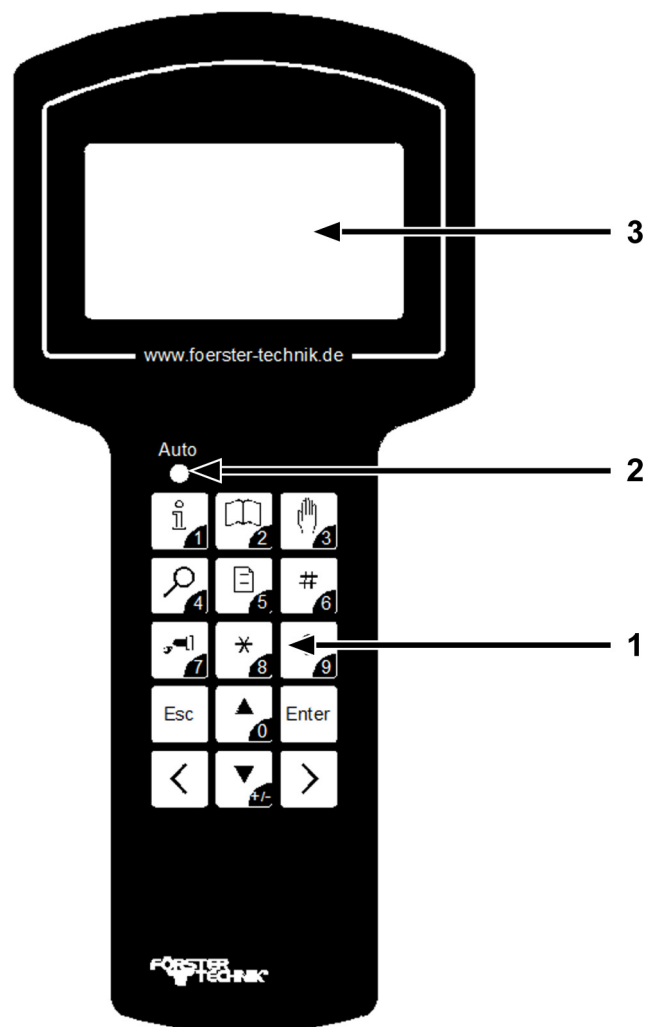

- 1 Keypad
- 2 Auto LED
- 3 Display

Keypad

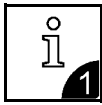

With this key, you open the **Animal control** menu and enter the numeral 1.



With this key, you open the **Main menu** and enter the numeral 2.



With this key, you open the **Manual functions** menu and enter the numeral 3.



With this key, you open the **Search functions** and enter the numeral 4.



With this key, you open the **Animal list** and enter the numeral 5.

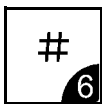

Key 6 can be freely assigned. With this key, you enter the numeral 6.



With this key, you activate the **Feeding pump** and enter the numeral 7.

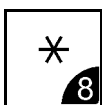

This key is assigned 2 functions:

- You press this key to select a calf in submenus in which an animal number is displayed. An asterisk (*) is displayed in front of the animal number of a selected calf.
- In the overview menu in automatic mode, you use this key to toggle between the four-line (large font) and the eight-line (small font) display.

With this key, you enter the numeral 8.

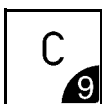

This key is assigned 2 functions depending on the menu you are currently in:

- In the Alarm submenu, you use this key to delete warnings and alarms.
- In the overview menu of automatic mode, you use this key to bring warnings to the foreground.

With this key, you enter the numeral 9.

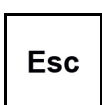

You use this key to go backward within the menu structure. You return to the starting menu by pressing this key multiple times.



You use this button to move the cursor upward and choose items from a list, for example [yes] or [no]. With this key, you enter the numeral 0.



With this key you move the cursor downward and select items from a list. You use this key to change the sign of a number, for example from +1 to -1. This is how you enter negative numbers.



You use this key to confirm your selection and open a menu such as an input field. An [input field] is indicated by square brackets.



You use this key to scroll between pages on the screen or list items to the left and jump to the end of a list.



You use this key to scroll between pages on the screen or list items to the right and jump to the end of a list.

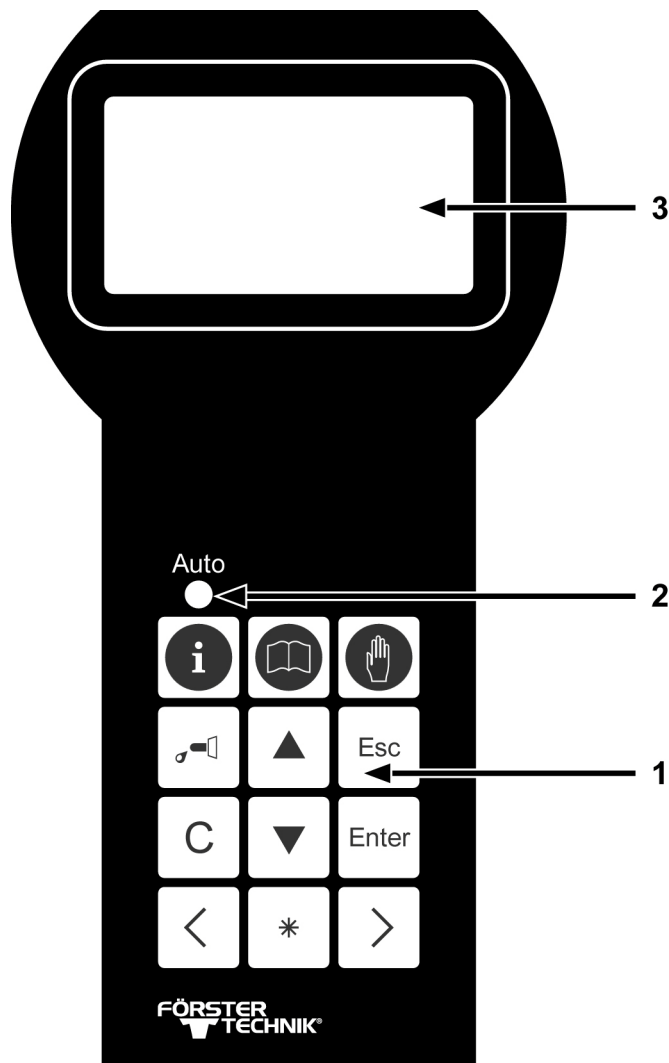

4.1.2 The 12-key hand terminal

Older versions of the automatic feeder still have the hand terminal with 12 keys.



- 1 Keypad
- 2 Auto LED
- 3 Display

The operation of this hand terminal differs from the operation of the 15-key hand terminal in the following ways:

- You cannot enter numbers directly via the keypad. In the menus in which you would like to enter numbers, use   to select a number and confirm your selection using .

- There are no freely assignable function keys. You access the animal list via the **Animal control** menu.
- You cannot save the data of the automatic feeder to an SD card.

4.1.3 Auto LED

The Auto LED (light-emitting diode) of the hand terminal displays important information about the status of the automatic feeder.

- In automatic mode, the LED lights up green.
- In offline mode, the LED is not lit up.
- If a malfunction occurs, the LED flashes.



You can operate the automatic feeder in offline mode or in automatic mode.

4.2 Offline mode

In offline mode, you perform tasks that cannot be performed while the unit is in operation, such as recalibrating feed components. When the automatic feeder switches from automatic to offline mode, the Auto LED goes out.

You switch to offline mode when you press  or when you open a menu that requires offline mode, such as the Calibrate menu.

You switch from automatic mode to offline mode as follows:



- Press .
 - Confirm the message **automatic mode terminate?** message by choosing .
- The Auto LED on your hand terminal goes out.
- Perform the desired action.

4.3 Automatic mode

You perform most routine tasks, such as feeding, in automatic mode. In automatic mode, the Auto LED lights up green.

After a prolonged period of inactivity, the automatic feeder automatically returns to automatic mode. This period is defined during setup.





You switch from offline mode to automatic mode as follows:

- Press  until the message **Start automatic mode?** appears in your display.
- Press .

You are now in automatic mode again. The Auto LED lights up green.

4.4 Menu structure

The automatic feeder is controlled using menus, submenus and lists. You control the automatic feeder by switching to lists via menus and submenus. In these lists, you check and change values. The menu structure makes it easier to find a list quickly.

The menus that end users require most frequently, such as **Animal control** , **Main menu**  and **Manual functions** , can be accessed with the press of button. The **Animal list** is the list that end users require most often. The animal list can be directly accessed by pressing the  key on the 15-key hand terminal. You can change this default setting during the initial startup process according to the end user's needs. The user will then access the animal list via the Animal control menu.

During initial startup of the automatic feeder, you can assign the  key in accordance with the needs of the end user.

If you do not see all the menus or submenus presented here, this is either because the automatic feeder is not equipped with the component in question, or the component was not activated during setup.

Note: If you know that the automatic feeder has a component that is not being displayed, check the setup.

4.4.1 Symbols

Symbols are displayed in front of and in several menus, submenus and lists.

4.4.1.1 Position arrows

In automatic mode, position arrows are displayed in front of menus:

- ► A shaded arrow indicates that the menu contains submenus.
- ▷ An unshaded arrow means that you can change settings here or perform actions.

4.4.1.2 Angle brackets

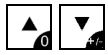

If angle brackets are displayed around a menu or list, it means that you can scroll left to right in order to select menu items or list items. For example, you can select the appropriate calf from a list of animal numbers using the calf's animal number.

4.4.1.3 Square brackets

[] Values or terms are in square brackets. When you press the value / list item begins to flash in the input field. You can now use the number keys to enter values or use to select values from a list, such as [yes] or [no].

Note: If you enter a value in an input field and the value is too high or too low, this value is automatically set to the highest (too high) or lowest (too low) possible value after you press .

4.4.1.4 Bar electrode free/covered

In automatic mode, these symbols are displayed at the top right of the display.



This symbol indicates that the feeding box is full. The tip of the bar electrode is in the liquid.



This symbol indicates that the feeding box is empty. The bar electrode is free.

4.4.1.5 Animal identification and feed consumption



The aerial symbol after a box number, such as TR 1 for feeding box 1, indicates that a calf has been identified at this box.

✓ A check mark after the aerial symbol means that calf identified at this box may consume feed here.



A lock symbol after the aerial symbol means that calf identified at this box may not consume feed here. For example, this could be because the milk ratio or the concentration of feed in the feeding box does not match the feed settings for the identified calf.

- A hyphen after the box number indicates that no calf was identified at this box.

4.4.1.6 Plan tendency

The arrow on the right beside the animal number indicates the feeding phase the selected calf is now in.

↗ The feed quantity increases continuously, for example at the beginning of the feeding plan.

→ The feed quantity remains constant, for example in the middle of the feeding plan.

↘ The feed quantity is continuously reduced, for example at the end of the feeding plan.

4.4.1.7 Marking



* Marked calves are indicated by an asterisk to the left of the animal number.

4.4.1.8 Alarms

! An exclamation mark to the left of the animal number indicates that a calf has triggered an alarm.

4.4.2 Navigation

You use the keys of the hand terminal to navigate through menus, submenus and lists.

You can use  .

- Navigate between the different submenus of a menu.
- Navigate between the items of a list, for example between [yes] and [no].

You can use  .

- Scroll screen by screen through a menu, for example to the submenus on the next page or directly to the last menu item.
- Scroll through a list, for example through animal numbers. At the end of the list, the message End of list appears in the display.

You can use .

- Confirm an entry.
- Confirm a prompt or message shown on the display.
- Confirm a selection.
- Open menus and submenus.
- To open input fields, which are indicated by square brackets.

- Switch from the number before the decimal place to the number after the decimal place in input fields.

You can use :

- Go back one menu each time you press the key. You return to the starting menu by pressing this key multiple times.
- Exit the input field or return to the number before the decimal place in an input field.

4.4.3 Menus

4.4.3.1 Animal control

You can choose  to open the **Animal control** menu. This menu contains all submenus that the end user requires for daily calf monitoring. The numbers next to the submenus indicate the number of calves recorded in the respective submenu.

- **Animal list.** A table is displayed that shows you calves, sorted by different parameters, such as visits to the feeding box.
- **Entitled.** A list of calves is displayed, sorted by feed entitlement.
- **Alarm.** A list of calves that have triggered an alarm is displayed.
- **Expire date.** A list of calves that have an expire date is displayed.
- **40FIT.** A list of calves currently in the 40FIT period is displayed.
- **Marked.** A list of calves that were marked is displayed.
- **New.** Here you can view animals that were newly registered in the last 2 days.
- **Doubled.** Here you assign a new animal number to calves that have been assigned a duplicate animal number.
- **Unknown.** Here you check whether and when the automatic feeder recorded unknown animal numbers. Here you can correctly register calves that have been recorded in this way.
- **All.** Is displayed .
- **Consumption.** Several lists are displayed with the consumption amounts of all calves, individual calves and individual groups.
- **Print.** Here you can print out the alarm list and the feed list.



4.4.3.2 Main menu

You can choose  to open the main menu. This menu contains all submenus that the end user requires for daily operation of the automatic feeder.



- **Animal management**
- **Feeding**
- **Calibration**
- **Device data**
- **Cleaning**
- **Diagnosis**

4.4.3.3 Manual functions

You can choose  to open manual functions. Here you can start certain functions of the automatic feeder manually. For example, you can manually empty the mixer or dispense extra portions.

When you press , the message **automatic mode terminate?** appears in the display. When you confirm the message by choosing , you switch the automatic feeder from automatic mode to manual mode. The Auto LED goes out.

The automatic feeder automatically returns to automatic mode after a prolonged period of inactivity. You set this period in the **Autostart** menu item on the offline screen. The default setting is 20 minutes. The Auto LED lights up green.

You can also actively switch the automatic feeder back to automatic mode. Press  until the message **Start automatic mode?** appears in the display. Confirm the message by choosing . The automatic feeder returns to automatic mode. The Auto LED lights up green.

You can start the following functions manually:

- **Extra portion.** Here you can dispense extra portions with and without additives.
- **Mixer: drain?.** The mixer is drained via the teat of the mixer drain valve.
- **Boiler water: start?.** You fill the boiler with water here.
- **Mixer: start?.** You start the mixer here.

- **Feeding box.** You open the feeding box valve(s) here.
- **Hoses: open?.** Here you can open several valves simultaneously in order to completely drain all the lines of the automatic feeder of water.

4.5 Device data

The following submenus can be found under **Device data**:

- **Operating modes**
- **Portion**
- **Date/time**
- **Boxes**
- **Function keys**
- **Animal list**
- **Data backup**
- **New installation**

4.5.1 Operating modes

In **Operating modes**, you set the operating modes of the feeder.

4.5.1.1 Rationed mode / ad lib mode

The automatic feeder operates in rationed mode by default, but can also be switched to ad lib mode.

- In **rationed mode**, the feeder uses animal identification, i.e., the animals are individually fed rationed amounts. Rationed mode is the default setting.
- The feeder does not use animal identification in **ad lib mode**. The **automatic reading** of transmitter numbers is therefore **not** possible in this operating mode. During feeder operation, a portion is always prepared as soon as the bar electrode in the feeding box is free (mixer empty). The feeding box valves are constantly open.

⚠ WARNING Risk of burns on feeding box valves. During prolonged ad lib mode, feeding box valves become hot. You, or the end user, can burn your fingers or hand when touching

these valves. For this reason, push on the suction hose directly onto the feeding box spout and pull the device plug out of the feeding box valve.

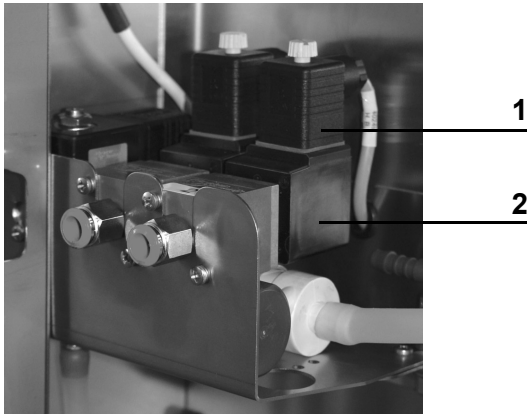

1	Female power connector
2	Box valve

ATTENTION Cleaning agent that enters the feed can be hazardous to the health of calves. Therefore, always disable all time-controlled cleaning menus during ad lib mode.

You set the operating mode as follows:

1. Choose  > **Device data** > **Operating modes** to go to the **Ad lib** submenu.
2. Select the option **yes** in the selection box to activate the ad lib mode. Choose **no** to select rationed mode.
3. In the subsequent lines, if necessary, adjust the values for the **feed concentration** and the **additive dosage**.

Note: These settings are taken into account during the preparation of all feed portions.

4.5.2 Checking and setting the time/date

During the initial startup process, you have to check and, if necessary, correct the time and the date. Time and date are shown in automatic mode.

Set the time of day, date and date format as follows:

1. Choose  > **Device data** to go to the **Time/date** submenu.
2. In **Time**, you enter the current time of day.
3. In **Date**, you enter the current date.

4. In **Format**, you choose the desired date format.

Note: In order to force an immediate daily offset after changing the date, you have to switch the feeder off and then on again.

4.5.3 Setting the portion

The automatic feeder and preparation of the feed are designed so that even a milk substitute with a higher fat melting point can be easily processed.

If animals are fed only whole milk or cold-soluble milk substitute, a lower temperature in the feeding box (e.g., 38°C) can be sufficient.

ATTENTION Feed temperatures that are too low can cause digestion problems in calves and feed temperatures that are too high can cause gastritis in the abomasum. The temperature of the feed in the feeding box must correspond to the mixing temperature specified by the MP manufacturer. Adhere to the feed temperatures recommended in this operating manual.

In this menu, you make the following settings for the feed portion:

- Set the set temperature of the feed in the feeding box.
- Set the minimum temperature of the water in the boiler.
- Set the parameters for outlet, for draining and for the mixer's OFF delay.

4.5.3.1 Setting the set and minimum temperature

Note: The first portion of feed, depending on the ambient temperature, is always mixed somewhat warmer.

Set the set temperature and the minimum temperature as follows:

1. Choose  > **Device data** > **Portion** to go to the **Set temp.** or **Min. temp.** submenu.
2. Enter the desired set temperature in **Set temp.** of the feed in the feeding box (= mixing temperature).
3. Enter the desired minimum temperature in **Min. temp.** for the water in the boiler.
Enter 0°C in **Min. temp.** in order to disable the minimum temperature parameter.
4. After entering the temperature, check whether the portion is being prepared with the set temperature.

	Set temperature	Minimum temperature
Default value:	42°C	39°C
Permitted range of values:	10°C to 44°C	0°C to set temperature minus 0.5°C

Note: The values that you have entered for set and minimum temperature are recalculated for the set and minimum temperature of the boiler water. If the temperature of the boiler water falls below the minimum temperature, the feed preparation will be interrupted until the minimum temperature has been reached again.

4.5.3.2 Mixer draining

Leftover feed in the mixer must be evacuated. This is done via the teat. Alternatively, you can choose not to evacuate residual amounts at all.

Leftover feed in the mixer can lead to an increased risk of infection when outdoor temperatures are high (summer). When outdoor temperatures are low (winter), leftover feed in the mixer becomes so cold that calves will no longer drink it. This can lead to malnutrition. Malnutrition can cause impaired growth and development, increased susceptibility to illness or even the death of your calves.

Leftover milk in the mixer provides a perfect breeding ground for germs. You specify the amount of time after which this leftover milk is discarded in order to ensure optimal feed hygiene. Mixer draining may also be followed by a drainage procedure (see section **Operation > Cleaning** in the operator's manual for the automatic feeder).

4.5.3.2.1 Mixer draining via mixer drain valve

The best and simplest solution is to evacuate the contents of the mixer via the mixer drain valve. You specify whether a mixer drain valve is present during setup (see **4.6.5.3 Mixer drain valve** on page **64**).

This function is only available if you have specified [yes] for the mixer drain.

Proceed as follows to specify the amount of time after which a remaining portion in the mixer will be evacuated:

1. Choose  > **Device data > Portion** to go to the **Draining** submenu.

2. In **Draining**, enter the desired period in minutes.

Default value:	15 min
Permitted range of values:	0 min (= draining deactivated), 5 to 120 min

4.5.3.2.1 Mixer draining via teat

If the automatic feeder does not have a mixer drain valve, the leftover food can be evacuated by using the **feeding pump** via the **teat**. Alternatively, you can choose not to evacuate residual amounts at all.

You set mixer drainage via the teat as follows:

1. Choose  > **Device data** > **Portion** to go to the **Drain via teat** submenu.
2. In the **Drain via teat** menu item, specify whether the mixer is to be drained.

4.5.3.2.1 Mixer OFF delay

You can change the runtime of the mixer in the **OFF delay** menu item. Whether and how long the mixer should have an OFF delay depends on the solubility of the milk substitute.

1. Choose  > **Device data** > **Portion** to go to the **Mixer OFF delay** submenu.
2. In **Mixer OFF delay**, enter the desired value.

Default value:	3 sec
Permitted range of values:	0 to 12 sec

4.5.4 Draining time box parameters



In the **Feed** menu, you can define the draining time for each feeding box. The draining time starts when the bar electrode becomes free for the last portion and ends when the respective feeding box valve closes.

If calves do not finish drinking the contents the feeding box within the standard setting for draining time, the draining time can be extended.

You can extend the draining time as follows:







1. Choose  > **Device data** > **Boxes** > **Feed** to go to the **Draining time** submenu.
2. In **Draining time**, you enter the desired time. You can enter values between 10 and 60 seconds. The default value is 16 seconds.

4.5.5 Function keys



The hand terminal has two freely programmable function keys  and . You define which functionality or which menu will be called up when the respective function key is pressed.

Note: This option is not available for automatic feeders with a 12-key hand terminal.

You define the function keys as follows:

1. Choose  > **Device data** to go to the **Function keys** submenu.
2. Choose  or  to go to the desired function, for example **Start mixer**.
3. Choose  to confirm.
4. Choose  or  to select the symbol of the function key to which the assignment is to be made.
 - The list symbol stands for the  key.

Note: This key is assigned the animal list by default.



- The hash symbol stands for the  key.
- The list symbol stands for the  key.

Note: This key is assigned the animal list by default.

- The hyphen [-] in the selection box is used for removing an assignment.

4.5.6 Animal list

Here you define which parameters are displayed in the two columns of the animal list.

1. Choose  > **Device data** to go to the **Animal list** submenu.
2. In **Column 1** or **Column 2**, choose  or  to select the parameter to be displayed in the respective column. You can choose between **Feed consumption**, **Drinking speed**, **Animal visits**, **Break-offs** and **Consumption**.

4.5.7 Backing up and restoring data

Every day at midnight, a backup of **animal data** and **device data** is performed automatically so that a current backup of data is available in case of data loss.

ATTENTION Data may be lost when the program version of the automatic feeder is updated or when the battery of the computer card is changed. You must also save the data of the automatic feeder manually, for example to an SD card. Otherwise, calves may suffer from malnutrition if incorrect feed portions are dispensed. Malnutrition can cause impaired growth and development, increased susceptibility to illness or even the death of your calves.

4.5.7.1 Internal data backup (automatic feeder)

4.5.7.1.1 Saving data

You save data as follows:

1. Choose  > **Device data** > **Data backup** to go to the **Internal (feeder)** submenu.
2. Confirm **save?** by choosing .

A progress bar informs you about the current status of the data backup being carried out.

4.5.7.1.1 Restoring data

You restore data as follows:

1. Choose  > **Device data** > **Data backup** to go to the **Internal (feeder)** submenu.
2. Confirm **restore?** .
3. Confirm the security prompt **restore last backup?** by choosing .

A progress bar informs you about the current status of the data backup being carried out.

4.5.7.1.1 Checking the current data backup

Check the data backup as follows:

1. Choose  > **Device data** > **Data backup** to go to the **Internal (feeder)** submenu.
2. In **last backup**, you can view the version, time and date of the last backup performed.

4.5.7.2 External data backup using an SD card

During each backup, a folder with the date of the backup is created on the SD card. In the case of a **recovery**, a date stored on the SD card can be entered and selected using the number field. The date of the last backup is always shown on the display.

Note: This option is not available for automatic feeders with a 12-key hand terminal.



SD card and hand terminal

Proceed as follows to perform a data backup using an SD card:

1. Open the rubber cover on the right side of your hand terminal
2. Insert the SD card.
3. Choose  > **Device data** > **Data backup** to go to the **SD card** menu.
4. Confirm **save?** by choosing .
5. Confirm **restore?** by choosing in order to perform a backup.

A progress bar informs you about the current status of the data backup being carried out.

This is how to perform a recovery:

1. If necessary, enter the date from which you want to recover the data and confirm your entry by choosing .
2. Confirm **restore?** by choosing in order to perform a backup.
3. In **Date**, you can see when the last data backup was performed.
4. Remove the SD card.
5. Close the rubber cover.

4.5.8 New installation

The program (software) must be completely reinstalled (reset) during the initial startup and restart process for the automatic feeder. This will remove superfluous data as well as no longer current or incorrect settings from the memory.

Note: New installation results in the deletion of the **animal data**. The **transmitter numbers** is set to zero and the **Device data** is overwritten with default values.

Animal data is, for example, group membership, barn transfer date, feeding days, consumption sums.

Device data includes portion settings, for example.

4.5.8.1 Only reinstalling device data, plans, animal data or transmitter numbers

Proceed as follows to reinstall device data, plans, animal data and transmitter numbers:

1. Choose  > **Device data** to go to the **New installation** submenu.
2. Confirm **Device data** by choosing .
3. Confirm **Reinstall device data?** by choosing .
4. Confirm the security prompt **Do you really want to restore the data to factory settings?** by choosing .

The message **New installation completed!** appears.

5. Confirm **New installation completed!** by choosing .
- You are back in the **New installation** menu.
6. Perform steps 2 to 5 in the same manner for **plans, animal data** or **transmitters**.

4.5.8.2 Reinstalling everything

You can also reinstall all menus instead of individual menus.

Reinstall all menus as follows:

1. Choose  > **Device data** to go to the **New installation** submenu.
2. Confirm **Everything** by choosing .
3. Confirm **Reinstall everything?** by choosing .
4. Confirm the security prompt **Do you really want to restore the data to factory settings?** by choosing .

The message **New installation completed!** appears.

5. Confirm **New installation completed!** by choosing .





All data has been reset to factory settings.

Note: The settings in the feeder setup are not changed by **new installation** .

4.6 Setup

The program menus in the setup menu contain basic settings, e.g. for the equipment of the automatic feeder. Check to ensure that the settings are correct.

You open the setup menu as follows:

1. Press  and keep this key pressed when you switch on the feeder.
After a short time, the setup menu will appear in the display.
2. If you want to change settings, go to the relevant menu item and make the changes.
3. Confirm your changes by choosing .
4. To exit the setup, press  until the message **setup terminate?** appears. Choose  to confirm.

4.6.1 Overview of setup menus

Language		German
Time/date		Date/time
Machine	Type	Powder
	Number	1-99 (= machine number, decimal)
	Address	2-FC (= CAN address, hexadecimal)
	System	Interval (IV)
	Operating mode	SA / SM
	Base size	250 ml
	Heater	mechanical / none
	Boiler valve	Basic
Equipment	⊕ Mixer drain	present yes / no?
	⊕ Additional dispenser 1	present yes / no?
	⊕ Detergent pump	present yes / no?
	Temperature sensor, mixer	present yes / no?
Identification	Type	Multi / Tiris / Nedap
	Squelch	0 to 255
ID chip	activated	no
⊕ Calibration scale	activated (yes / no)	
	adjust?	
	Cal. factor	
	Cal. date	
Boxes	Feed	<internal 1>, <internal 2>
		<IFS feed 1 .. 8>
	⊕ Concentrate	<IFS-C 1 .. 8>
		Allocation: [Concentrate box 1 .. 8]
		Address: 51-60
		Type: Standard
	⊕ Animal scales	Activate
		Adjust
Terminal	Address	1-FC (= CAN address, hexadecimal)
	Contrast	70 %

Communication	Institut	yes/no
	⊕ Printer	no / serial / CAN
	⊕ Gateway	MAC:
		IP: 0-255 . 0-255 . 0-255 . 0-255 SN: 0-255 . 0-255 . 0-255 . 0-255 IP assignment: manual / autom. Factory settings?
CAN analyzer	CAN devices	
	CAN errors	
	CAN load	
SD card	Read feeding plans	active / changed
	Read licenses	Request license/ Read data/ Active licenses
Service	Enter Servicetype[RS1/RS2/RS3]	last service / next service accept?

4.6.2 Language

You select the language for the user interface of the feeder as follows:

1. In the setup menu, choose the **Language** menu item.
2. Select the desired language for the user interface.
3. Confirm your entry by choosing .

4.6.3 Time/date

You set the time / date as follows:

1. In the setup menu, choose the **Time / date** menu item.
2. Enter the current time of day and the current date.
3. Confirm your entries by choosing .

4.6.4 Machine

4.6.4.1 Feeder type

There are three different automatic feeder types:

- **Powder:** feeds MP water mixtures.
- **Combi:** feeds fresh milk as well as MP water mixtures.
- **Milk:** feeds fresh milk only.

You select the feeder type as follows:

1. Leave the factory default value as it is.

4.6.4.2 Feeder number

In order for the KalbManagerWIN program (optional additional equipment) can access the software of the automatic feeder, the automatic feeder needs a number. Number 1 is set by default.

Note: When connecting more than one automatic feeder, be sure that each number is only assigned once.

You select the feeder number as follows:

1. In the setup menu, choose the **Machine** menu item.
2. In **Number**, you select a number.
3. Confirm your entry by choosing .

4.6.4.3 Feeder address

For clear identification, every participant of the CAN bus system needs an address.

Address ranges for CAN participants	
1-10	=> hand terminal
11-20	=> automatic feeder
41-50	=> IFS feed single
51-60	=> IFS-C
61-70	=> IFS feed quadruple

You select the feeder address as follows:

1. In the setup menu, choose the **Machine** menu item.
2. In **Address**, you select an address.
3. Confirm your entry by choosing .

Note: If you select an address that has already been assigned, the message **Address already assigned!** appears in the display.

4.6.4.4 Feeder operating mode

The automatic feeder can be operated in **Stand Alone (SA)** mode or **System machine** mode. Please leave the factory set value **SA** (= Stand Alone) as it is.

4.6.4.5 Animal number

An automatic feeder can manage a maximum of 50 calves.

You select the number of animals as follows:

1. In the setup menu, choose the **Machine** menu item.
2. In **Animal number**, select 50.
3. Confirm your entry by choosing .

4.6.4.6 Base size

The defined value determines:

- The set quantity for calibrating **water Boiler**.
- The standard portion size.

You define the size as follows:

1. In the setup menu, choose the **Machine** menu item.
2. In **Base size** enter 250.
3. Confirm your entry by choosing .

4.6.4.7 Heater

Here you specify whether the feeder has a heater and, if so, what type of **heating relay** it has.

You set the heating type as follows:

1. In the setup menu, choose the **Machine** menu item.
2. In **Heating**, select **mechanical**.
3. Confirm your entry by choosing .

4.6.4.8 Water valve Boiler

Please do not change the factory settings.

4.6.5 Equipment

Here you specify whether the automatic feeder is equipped with certain components or options.

4.6.5.1 Feeding pump

The feeding pump is included by default. It helps the animals become used to the automatic feeder. The feeding pump can also be used to drain the feeding box.

You set the feeding pump as follows:

- In the setup menu, open the **Equipment** menu item.
- In **Feeding pump**, choose **yes** if a feeding pump is present, otherwise choose **no**.
- Confirm your entry by choosing .

4.6.5.2 Temperature sensor, mixer

The temperature sensor in the mixer continually records the temperature of the feed in the feeding box. If the temperature deviates from the set value, the boiler heater is readjusted. The feed always has the desired temperature, regardless of the season.

You set the mixer temperature sensor as follows:

1. In the setup menu, open the **Equipment** menu item.
2. In **Mix. sensor T**, choose **yes** if a temperature sensor is present, otherwise choose **no**.
3. Confirm your entry by choosing .

4.6.5.3 Mixer drain valve

The contents of the mixer can be drained completely automatically via the mixer drain valve.

You set the mixer drain valve as follows:

1. In the setup menu, open the **Equipment** menu item.
2. In **Mixer drain valve**, choose **yes** if a mixer drain valve is present, otherwise choose **no**.
3. Confirm your entry by choosing .

4.6.6 Identification

Type and squelch

Here you set the identification system, depending on the identification system of the distribution partner. The input or reading sensitivity of the identification system is set via the squelch value. The larger the entered value, the lower the range of the identification.

You set the identification system as follows:

1. In the setup menu, open the **Identification** menu item.
2. In **Type**, select the identification system.
3. In **Squelch**, select the squelch value.
4. Confirm your entry by choosing .

4.6.7 Terminal

4.6.7.1 Address

The hand terminal is integrated into the CAN bus system of the automatic feeder. That is why it needs its own address. **Address 1** is set by default.

Note: In a CAN bus system, an address may only be assigned once.

You set the address as follows:

1. In the setup menu, choose the **Terminal** menu item.
2. In **Address**, select **[1]**.
3. Confirm your entry by choosing .

4.6.7.2 Contrast

You set the contrast as follows:

1. In the setup menu, choose the **Terminal** menu item.
2. In **Contrast**, enter the desired value. The default value is 60%.
3. Confirm your entry by choosing .

4.7 Transmitter and animal management

All menus for management of the list of all transmitters and the calves registered at the feeder can be found via  > **Animal management**.

4.7.1 Managing transmitters

4.7.1.1 Basics

4.7.1.1.1 Identification process at the box

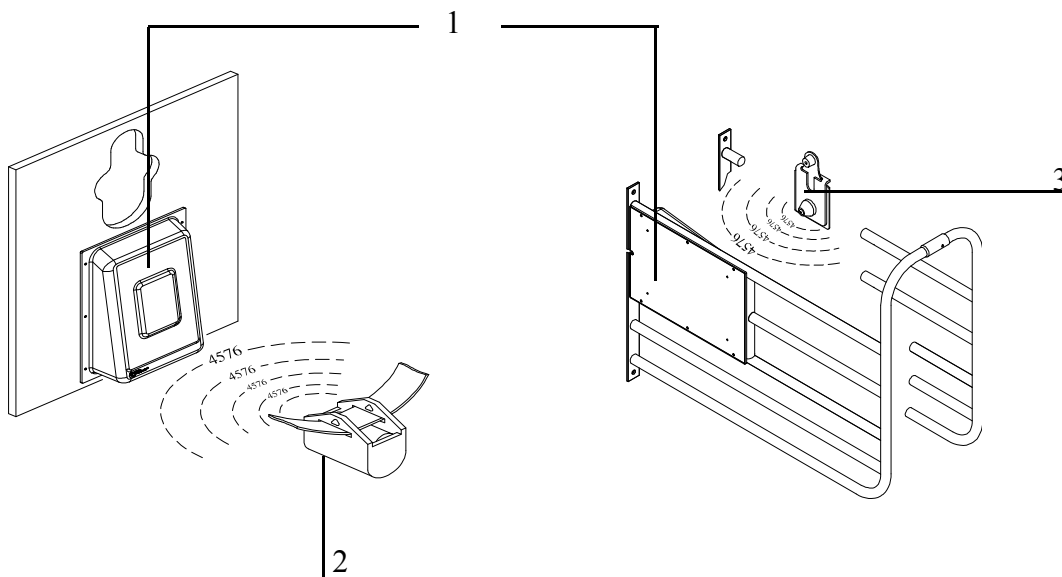

1	Aerial
2	Collar transmitter
3	Earmark transmitter

For identification purposes, each calf wears a collar with a transmitter or an earmark with a transmitter. The transmitter has a multi-digit number, which is also usually stamped into the transmitter housing. This **transmitter number** is sent from the transmitter to the aerial, which is part of the feeding box.

4.7.1.1.1 Connection of transmitters and animal numbers

The multi-digit transmitter number is not well suited for the quick location of individual calves. For that reason, a calf is issued an animal number along with the transmitter number. The animal wears this animal number on an easily readable collar, or the animal number is put on the earmark where it can be easily read. Up to 50 different animal numbers of up to six digits can be assigned to the calves.

4.7.1.2 Creating transmitter numbers

During the initial startup of process for the feeder, existing transmitters have to be created once in the system. When this is done, each transmitter number is assigned one animal number of no more than six digits. These animal numbers are then available and can be used to register the calves.

4.7.1.2.1 Reading transmitter numbers

When creating new transmitter numbers, it is a good idea to have these read by the feeder. This saves you from typing in the numbers and eliminates the possibility of typing errors.

To set up the reading of transmitter numbers by the feeder, proceed as follows:

1. Choose  > **Animal management > Transmitters** to go to the **New** submenu.
2. Hold a transmitter next to the identification unit of a feeding box.
The number of the transmitter is read and displayed in the line behind **No..** At the same time, the animal number which is to be newly assigned is suggested in the **Animal No.** line.
Note: You can influence the suggested animal number by selecting an assignment scheme for the animal numbers in the **No.** line.
3. Check whether the suggested **animal number** is correct and, in the line **accept?**, press .
4. In order to allocate the newly read transmitter number to the displayed animal number, confirm the security prompt **Create new no. xxx for animal xx?** by choosing .

4.7.1.2.1 Manually entering transmitter numbers

Instead of reading the transmitters, you can also manually type in the transmitter numbers, if necessary

You manually enter transmitter numbers as follows:

1. Choose  > **Animal management > Transmitters** to go to the **New** submenu.
2. Enter the transmitter number in **No..**
3. In **Animal No.**, check the suggested animal number and confirm it by choosing .
4. Confirm **accept?** by choosing .
5. In order to allocate the entered transmitter number to the displayed animal number, confirm the security query **no. xxx for animal xx create new?** by choosing .

4.7.1.3 Assigning animal numbers

If the transmitter numbers are automatically read when new numbers are created, an animal number is automatically suggested. When doing this, there are two schemes to choose from for number assignment.

4.7.1.3.1 Consecutive assignment of animal numbers

There is a counter which counts up for each new transmitter number as it is read. In this way, all of the transmitter numbers which are recorded by the identification are linked to consecutive animal numbers; e.g., from 1 to 50.

You set up consecutive assignment of animal numbers as follows:

1. Choose  > **Animal management > Transmitters** to go to the **New** submenu.
2. Select the **consecutive** option in **No.**.
3. If necessary, in **next**, specify the animal number at which you want automatic reading of transmitters to start.

Note: If you use collars, it makes sense to start with 1 and read the transmitters in order.

4.7.1.3.1 Assignment of animal numbers based on transmitter numbers

More and more often, calves are already equipped with an electronic earmark transmitter when they are born and keep this earmark their whole lives. The automatic feeder program has been adapted for this type of transmitter so that the registration process of the transmitters and calves can take place completely automatically.

You set up automatic assignment of animal numbers as follows:

1. Choose  > **Animal management > Transmitters** to go to the **New** submenu.
2. Select the **automatic** option in **No.**.
3. In **Range**, define the numeral range of the transmitter number that you want to use as the animal number. The animal number can have a maximum of six digits.

Example: 5-2 means that – counting from the right – the second to the fifth numeral of the transmitter number is accepted as the animal number. **6-1** means that – counting from the right – the first to the sixth numeral of the transmitter number is accepted as the animal number.

4.7.1.4 Editing transmitters or animal numbers

In necessary, (e.g., if a transmitter is lost), a transmitter number can be subsequently changed or deleted.

4.7.1.4.1 Changing the transmitter number

Manually changing the transmitter number

You manually change a transmitter number as follows:

1. Choose  > **Animal management > Transmitters** to go to the **Edit** submenu.
2. Select the transmitter number to be changed.
3. Change the transmitter number in **No.** and confirm by choosing .

Reading the new transmitter number for the change

You read a new transmitter number as follows:

1. Choose  > **Animal management > Transmitters** to go to the **Edit** submenu.
 2. Select the transmitter number to be changed.
 3. Confirm **read?** by choosing .
- A new menu is displayed, and the transmitter number flashes in the first line.
4. Hold the transmitter that you want to read next to the identification unit.
The number is automatically accepted in the first line.
 5. Confirm **accept?** by choosing .

4.7.1.4.1 Changing the animal number

Like the transmitter number, the animal number can also be changed.

1. Choose  > **Animal management > Transmitters** to go to the **Edit** submenu.
2. Select the animal number you want to change.
3. In **Animal No.**, change the animal number that is currently allocated to the transmitter and confirm by choosing .

4.7.1.4.1 Deleting transmitter numbers

You delete transmitter numbers as follows:

1. Choose  > **Animal management > Transmitters** to go to the **Edit** submenu.

2. Select the transmitter number to be deleted and confirm **delete** by choosing .

Note: You can only delete transmitter numbers from calves that are not registered (= status: available).

4.7.1.5 Deleting the transmitter number when cancelling an animal

Generally, the collars (or earmarks) with the respective transmitters remain at the organization and are reused after the calf is taken out of the pen and cancelled. For this reason, the default setting when cancelling of a calf is to not delete its transmitter number. If the transmitter of a calf is, however, **not** reused but rather stays with the calf, (lifelong earmark), make the following setting in the feeder:

1. Choose  > **Animal management** > **Cancel** to go to the **Settings** submenu.
2. Select the **yes** option in **Delete no..** When a calf is canceled, the transmitter number is also deleted along with the animal number. This prevents an accumulation of unused transmitter numbers, which would use up the available storage space.

4.7.1.6 Calling up the transmitter statistics

You call up a transmitter statistic as follows:

1. Choose  > **Animal management** > **Transmitters** to go to the **Information** submenu.
2. An overview of the transmitters created in the system is displayed. The following is listed in the displayed list:
 - In **Registered**, you check the number of registered transmitters or calves.
 - In **Available** you check the number of available transmitters.
 - In **Free**, you check how many transmitters you can still create.

4.7.2 Registering animals

Calves are only fed at the feeder if they are also registered there. You can either manually register each calf or instruct the feeder to automatically register the calves. In the latter case, the calf is registered as soon as it enters the feeding box for the first time. This means that the manual registering of the calves is not needed.

During registration, the calf is allocated to one of four groups, A to D. The calf will then be fed in accordance with the feed and concentration plans of this group.

The group to which you allocate the calves depends solely on the feed quantity, concentration that the end user wants to feed the calves. In this case, it does not matter which box the calves consume their feed in or which bay the calves have been housed in.

4.7.2.1 Registering animals manually

You register animals manually as follows:

1. Choose  > **Animal management > Register** to go to the **Animal** submenu.
2. Select one of the available (not yet registered) animal numbers.
3. In **Group**, select the group to which the calf is to be allocated.
4. If you want to reduce the total feeding duration for the calf, you can set this up under **Correction days** (see **Operation > Feeding > Total feeding duration** in the operator's manual).
5. Confirm **register?** by choosing .
6. Confirm the prompt **Animal xx in group X register?** by choosing .

Note: On its registration day, the animal receives the exact amount of feed, spread over the course of the day, as is intended for it by the feeding plan for the first day. If you have entered correction days, then the animal will receive the feed that is intended for the respective day.

4.7.2.2 Registering animals automatically

If an animal that is not yet registered enters the feeding box for the first time, it can then be automatically registered. With regard to automatic registration, three different modes can be set which are described in detail in the following three subchapters. The following table presents an overview of this.

Overview of the three modes for automatic registration

Automatic registration mode	Transmitter number in identification	
	available	unknown
deactivated	Unknown transmitters warning	Unknown transmitters warning
available transmitters	Animal is registered	Unknown transmitters warning
all transmitters	Animal is registered	Transmitter is created, new animal number is assigned, animal is registered

4.7.2.2.1 Deactivating automatic registration

Automatic registration is deactivated by default. You can restore this setting at any time:

You deactivate automatic registration as follows:

1. Choose  > **Animal management** > **Register** to go to the **Automatic** submenu.
2. Select **Mode no** and confirm by choosing . Automatic registration is then deactivated.

Note: When the registration function is deactivated, the **unknown transmitters warning** is triggered if an unregistered calf enters a box.

4.7.2.2.1 Only automatically register available transmitters

Automatic registration shortens the registration process for the calves. When doing this, you can specify that only calves can be registered whose transmitter numbers are already in the system. If an available transmitter number is registered in the identification unit, the respective calf will be automatically registered. Calves or transmitter numbers that have not yet been created in the system trigger the **Unknown transmitter numbers** warning.

Proceed as follows to set up automatic registration of available transmitters:

1. Choose  > **Animal management** > **Register** to go to the **Automatic** submenu.
2. Select the **available** option in **Mode**.
3. In **Group**, choose the group in which you want to automatically register the calves.

Note: Those calves that are to be removed should only be deregistered after they have left the bay, since they will otherwise be automatically reregistered when they enter the box and will then be returned to the start of the feeding plan.

4.7.2.2.1 Creating transmitter numbers and automatically registering calves

In order to shorten the registration process even more, you can specify that calves can also be registered if their transmitter numbers are not known in the system. This eliminates the need for reading or manual entry of transmitter numbers. In this case, if an unknown transmitter number is registered in the identification unit, this transmitter number is automatically created in the system and a new animal number is issued and registered at the same time.

Note: When creating new transmitters and animal numbers, the animal number is assigned consecutively or as a part of the transmitter number (see **Animal number assignment**). Clarify whether this kind of number assignment is actually what the end users wants.

Proceed as follows to create transmitter numbers and automatically register calves:

1. Choose  > **Animal management** > **Register** to go to the **Automatic** submenu.
2. Select the **All** option in **Mode**.
3. In **Group**, choose the group in which you want to automatically register the calves.

Note: Calves **without collars** may never be in the bay. They could push other animals out of the way and steal remaining amounts.

4.7.3 Canceling animals or animal groups

Individual calves or a group of calves that are no longer being fed according to the plan must be removed from the pen compartment and canceled. The same applies to calves whose feeding plan has expired.

4.7.3.1 Cancelling individual animals

You cancel an individual animal as follows:

1. Choose  > **Animal management** > **Cancel** to go to the **Animal** submenu.
2. Select the desired animal number.
3. In **End of plan**, you check how much longer the calf is to be fed according to the plan.
4. In **MP**, you can check how much milk powder the calf has consumed from registration to cancellation.

5. Confirm **cancel?** by choosing in order cancel a calf.

ATTENTION Risk of malnutrition if calves do not receive any feed. Malnutrition can cause impaired growth and development, increased susceptibility to illness or even the death of your calves. Tell the end user that he/she must provide the canceled calves with feed using an alternative method.

Note: If you have chosen the value **All** or **Available** for the **automatic registration mode**, you should remove unregistered calves from the bay, since otherwise they will be automatically registered again.

4.7.3.2 Registering a group

You cancel a group as follows:

1. Choose  > **Animal management** > **Cancel** to go to the **Group** submenu.
2. Select the desired group.
3. In **Registered**, you can see how many calves are being fed according to a certain plan.
4. In **Weaned** you can see how many calves have finished the feeding plan and are therefore no longer receiving any feed.
5. Confirm **Cancel** by choosing if all calves in the group are to be cancelled regardless of whether they are registered or weaned calves.
6. Confirm the security prompt **Cancel animals in group?** by choosing .

4.7.3.3 Canceling weaned animals

You cancel weaned calves as follows:

1. Choose  > **Animal management** > **Cancel** to go to the **Weaned animals** submenu.
2. Confirm **cancel?** by choosing if weaned calves are to be canceled.
3. Confirm the security prompt **Cancel animals?** by choosing .

4.7.4 Changing the registration of animals

You can change calves registered at an automatic feeder to another group at any time:

To change registered calf to another group, proceed as follows:

1. Choose  > **Animal management** to go to the **Change registration** submenu.
2. Select the desired calf.

3. Select the desired feeding group in **Group**.
4. Confirm the prompt **Animal xx in group X change registration?** by choosing .

Note: When registration is changed, the feeding day is retained; the calf is **not** reset to the start of the feeding plan (= to plan day 1).

5 Failures and warnings

5.1 Failures and warnings



The automatic feeder shows failure messages or warning messages in the display to indicate failures during feeder operation.

In the event of a **failure**, automatic mode is interrupted and no feed is prepared.

ATTENTION An interruption in feeder operation means that your calves will not receive any feed. This can lead to malnutrition. Malnutrition can cause impaired growth and development, increased susceptibility to illness or even the death of your calves. Tell the end user that he/she must provide the calves with feed using an alternative method if feed operation is interrupted.

In the case of a **warning**, automatic mode is not interrupted, and feeder operation continues.

Once you have eliminated the failure, delete the failure and warning messages.

- Some failure and warning messages are deleted automatically.
- Some failure and warning messages can be deleted by pressing .
- Some failure and warning messages are deleted by confirming **Delete failure?** or **Delete warning?** by choosing .

5.1.1 Failures



5.1.1.1 CRC error

Failure, CRC error is shown in the display if data records in the memory of the control unit have been destroyed. The following variations can be displayed:

- Check animal.
- Check device data.
- Check plans.
- Check prescriptions.

Feeder operation is interrupted. Make sure that the end user provides the calves with feed using an alternative method as long as feed operation is interrupted.

Reinstall the program as follows:

- To reinstall the program, choose  > **Device data** > **New installation** to go to the **Everything** submenu.
- Confirm **new installation?** by choosing .

Note: The personal settings of the end user are deleted and replaced by predefined default values.

5.1.1.2 Heating

failure heating xx.x °C is shown in the display when the temperature of the boiler water is too low. Feeder operation is interrupted until the set minimum temperature has been reached. Make sure that the end user provides the calves with feed using an alternative method as long as feed operation is interrupted.

You eliminate the failure as follows:



If heating up the boiler water does not solve the problem:

1. Choose  > **Device data** > **Portion** to go to the **Set temp.** or **Min. temp.** submenu and check the temperature settings.
2. Check the heater for proper functioning.

5.1.1.3 Temperature too high

Failure, temperature too high appears in the display when the water temperature in the boiler is too high. Feeder operation is interrupted until the water in the boiler has cooled to the set maximum temperature. Make sure that the end user provides the calves with feed using an alternative method as long as feed operation is interrupted.

You eliminate the failure as follows:

1. Confirm **Failure, temperature too high** by choosing .
2. In **HE water start?** hold down .
3. Release water from the heat exchanger's boiler into the mixer until the failure message in the display goes out.
4. Confirm **Mixer: drain?** by choosing .

Check the temperature of the supplied water if the heat exchanger is charged with preheated water.

5.1.1.4 Boiler not filled

When the automatic feeder turns on, the control unit checks whether the **Boiler** is filled with water. If it is not filled, feeder operation is interrupted and **Failure, boiler not filled** appears in the display.

Feeder operation is interrupted. Make sure that the end user provides the calves with feed using an alternative method as long as feed operation is interrupted.

You eliminate the failure as follows:

1. Check the water supply
2. In **Boiler: fill?**, press .
3. Check whether the water jet strikes the bar electrode and the display shows **covered**.
4. In **Boiler water start?**, press .
5. Check whether the shutoff valves and the drain valve are not leaking.

Note: If liquid flows into the mixer through these valves, the bar electrode cannot be grounded.

5.1.1.5 Water shortage

If the bar electrode is not grounded in the feeding box when water is being added, a water test is started. If the water test is not successful, then feed preparation and animal identification are switched off. **Failure, water shortage** appears in the display.

Feeder operation is interrupted. Make sure that the end user provides the calves with feed using an alternative method as long as feed operation is interrupted.

You eliminate the failure as follows:

1. Confirm **Boiler water start?** by choosing .
2. Check whether the water jet strikes the bar electrode.
3. Check the water supply to the automatic feeder.
4. Check whether deposits such as calcium have formed on the electrode.
5. Confirm **Delete failure?** by choosing .

⚠ DANGER Lethal electric shock. The electrical components of the automatic feeder are live. Always turn off the automatic feeder using the control switch and disconnect the mains plug before you change the response sensitivity of the electrode.

Check and change the response sensitivity of the electrode.

1. Choose  > **Diagnosis > Sensors** to go to the **EI. bar** submenu.
2. In the right-hand column, check the status (**free** or **covered**).
3. Confirm **EI. bar** by choosing .

 - In **Status**, check the status (**free** or **covered**).

4. Confirm **Boiler water: start?** by choosing .

The electrode is triggered if **water** is dispensed into the feeding box.

- Confirm **Mixer: drain?** by choosing in order to evacuate the liquid.
5. Visually inspect the electrode.
 - If the electrode reports that it is **covered** although it is actually free, the response sensitivity of the electrode is too high.
 - Reduce the response sensitivity of the electrode by rotating the potentiometer (see machine circuit diagram in the appendix) counterclockwise on the main board.
 - If the electrode reports that it is **free** although it is actually covered, the response sensitivity of the electrode is too low.
 - Increase the response sensitivity of the electrode by rotating the potentiometer (see machine circuit diagram in the appendix) clockwise on the main board.

5.1.1.6 Mixer emptying

Failure, mixer emptying appears if the mixer cannot be drained.

Feeder operation is interrupted. Make sure that the end user provides the calves with feed using an alternative method as long as feed operation is interrupted.

You eliminate the failure as follows:

⚠ DANGER Lethal electric shock. The electrical components of the automatic feeder are live. Always turn off the automatic feeder using the control switch and disconnect the mains plug before you perform work on the feeder's components.

1. Turn off the automatic feeder using the control switch and disconnect the mains plug.
2. Check all feed-conducting components from the mixer up to the teat for clogs and remove them.

ATTENTION The hose from the mixer drain valve to the drain shaft may not be lengthened.

Check the feeding pump:

1. Confirm **Feeding pump start?** by choosing .
2. Check the bar electrode:
3. Confirm **Bo. water start?** by choosing to fill the mixer with water.
4. In **Mixer emptying?**, confirm by choosing .
5. Confirm **Delete failure?** by choosing if you have eliminated the failure.
6. Remove detergent remnants from feed-conducting components by rinsing them with water.

ATTENTION Detergent remnants that enter the feed can be hazardous to the health of calves. Remove detergent remnants before restarting the automatic feeder.

7. Insert the mains plug again and turn on the automatic feeder using the control switch.
8. Return to automatic mode.

5.1.1.7 Heater

Failure, heating is shown in the display if the heater is defective.

Feeder operation is interrupted. Make sure that the end user provides the calves with feed using an alternative method as long as feed operation is interrupted.

You eliminate the failure as follows:

⚠ DANGER Lethal electric shock. The electrical components of the automatic feeder are live. Always turn off the automatic feeder using the control switch and disconnect the mains plug before you perform work on the feeder's components.

1. Check the heating rod for continuity.
If the heating rod is defective, replace it.
2. Check the temperature sensor.
If the temperature sensor is defective, replace it.
3. Check whether voltage is applied to the heater. Check the customer's fuses.
4. Check whether safety temperature limiter has been triggered.

⚠ DANGER Lethal electric shock. The electrical components of the automatic feeder are live. Always turn off the automatic feeder using the control switch and disconnect the mains plug before you reactivate the safety temperature limiter.

You reactivate the safety temperature limiter as follows:

1. Confirm **Delete failure** by choosing .
2. Turn off the automatic feeder using the control switch and disconnect the mains plug.
3. Open the right side door of the automatic feeder.
4. Remove the metal cover under which the safety temperature limiter is located.
5. Press the red reset button in order to reset the safety temperature limiter.
6. Reattach the metal cover.
7. Close the side door.
8. Reinsert the mains plug and turn on the automatic feeder again using the control switch.

5.1.1.8 Boiler temperature sensor

Failure, Temp. sensor, boiler is shown in the display if the temperature sensor of the boiler is defective.

Feeder operation is interrupted. Make sure that the end user provides the calves with feed using an alternative method as long as feed operation is interrupted.

You eliminate the failure as follows:

⚠ DANGER Lethal electric shock. The electrical components of the automatic feeder are live. Always turn off the automatic feeder using the control switch and disconnect the mains plug before you work on the main board.

1. Turn off the automatic feeder using the control switch and disconnect the mains plug.
2. Remove the metal cover on the back of the automatic feeder.
3. Measure the resistance of the temperature sensor on the main board.
4. Compare the measured value with the value in the table. The table can be found in the machine circuit diagram in the appendix.
5. If the measured value differs from the value in the table, you must replace the sensor. (see machine circuit diagram in the appendix).
6. Reattach the metal cover.
7. Reinsert the mains plug and turn on the automatic feeder again using the control switch.

5.1.1.9 Calibration

Failure, calibration is shown in the display if the liquid or powder feed components and the detergent are not calibrated.

Feeder operation is interrupted. Make sure that the end user provides the calves with feed using an alternative method as long as feed operation is interrupted.

You eliminate the failure as follows:

1. Calibrate all components shown in the display. (see section **Operation > Manual recalibration** in the operator's manual).
2. Confirm **Delete failure?** by choosing if you have eliminated the failure.

5.1.1.10 Box/drain valve

Failure, Box/drain valve is shown in the display if a feeding box valve is leaking. The automatic feeder loses water during cleaning.

Feeder operation is interrupted. Make sure that the end user provides the calves with feed using an alternative method as long as feed operation is interrupted.

You eliminate the failure as follows:

1. Check all feeding box valves for leaks.
 - Clean leaky valves in order to remove any foreign objects that might have entered the system.

- Repair leaky valves or replace them.
2. Check the bar electrode.
 - Choose  > **Diagnosis > Sensors** to go to the **EI. bar** submenu.
 - In the right-hand column, check the status (**free** or **covered**).
 - Confirm **EI. bar** by choosing .
 - In **Status**, check the status (**free** or **covered**).
 3. Confirm **Boiler water: start?** by choosing .
 - The electrode must report that it is **covered** if **water** is dispensed into the feeding box.
 - If the bar electrode reports that it is **free**, you must readjust the sensitivity of the bar electrode (see **5.1.1.5 Water shortage** on page **79**).
 - If the failure persists, you must replace the bar electrode.
 4. Confirm **Delete failure** by choosing once you have eliminated the failure.

5.1.1.11 Uncontrolled output

The automatic feeder monitors all outputs during current operation which are responsible for the dispensing of water, milk, milk powder, additives and detergent. If the corresponding relays are actuated for more than 60 seconds, the failure **Uncontrol. output** will appear in the display. Depending on the type of defect, one of the following failure codes will be displayed:

- **Circulation valve**, if the circulation valve is defective.
- **Bo. water**, if the boiler water valve is defective.
- **Mixer drain**, if the mixer drain valve is defective.
- **Powder**, if the motor of the milk powder conveyor is defective.
- **Additive dispenser**, if the additive dispenser is defective.

Feeder operation is interrupted. Make sure that the end user provides the calves with feed using an alternative method as long as feed operation is interrupted.

You eliminate the failure as follows:

- Check the water valve of the boiler.
 - 1 Choose  > **Diagnosis** to go to the **Valves** submenu.
 - 2 Confirm **Bo. water open?** by choosing to open the water valve. The valve remains open as long as you hold down .
 - 3 Check whether the valve opens. The valve opens when the water is dispensed.
 - 4 Repair the valve or replace it.

- Check the circulation valve.
 - 1 Choose  > **Diagnosis** to go to the **Valves** submenu.
 - 2 Confirm **Circulation valve open?** by choosing to open the circulation valve.
 - 3 Listen to check whether the valve opens.
 - 4 If a valve is defective, repair or replace it.

- Check the mixer drain valve.
 - 1 Choose  > **Diagnosis** to go to the **Valves** submenu.
 - 2 Confirm **Mixer drain open?** by choosing to open the mixer drain valve. The valve remains open as long as you hold down .
 - 3 Check whether the valve opens. The valve opens when the water drains.
 - 4 Repair the valve or replace it.

- Check the motor of the milk powder conveyor.
 - 1 Choose  > **Diagnosis** to go to the **Motors** submenu.
 - 2 Confirm **Powder start?** by choosing in order to start the motor of the powder conveyor.
 - 3 If the motor does not start, check the plug on the powder conveyor or check the power supply.

- Check the additive dispenser.
 - 1 Choose  > **Diagnosis** > **Motors** to go to the **Additive** submenu.
 - 2 Confirm **Start?** by choosing in order to start the motor of the milk powder conveyor.
 - 3 If the motor does not start, check the plug or the power supply.

5.1.2 Warnings

5.1.2.1 Mixer emptying

Mixer emptying warning appears if the mixer cannot be drained. For example, this can be because the drain is clogged or the feeding pump is no longer running.

This warning message is always hidden when the bar electrode becomes free.

⚠ DANGER Lethal electric shock. The electrical components of the automatic feeder are live. Always turn off the automatic feeder using the control switch and disconnect the mains plug before you perform work on the feeder's components.

You eliminate the failure as follows:

1. Check all feed-conducting components from the mixer up to the teat for clogs and remove them.
 2. Check the feeding pump.
 - 2.1 Confirm **Mixer emptying warning** by choosing .
 - 2.2 Confirm **Feeding pump: start?** by choosing .
 - 2.3 The mixer is evacuated.
 3. Check the bar electrode.
 - 3.1 Visually check the bar electrode for deposits.
 - 3.2 Check the bar electrode for proper functioning (see **5.3.3** Checking sensors on page **96**).
 4. Fill and drain the mixer.
 - 4.1 Confirm the **Mixer emptying warning** by choosing .
 5. Confirm **Water bo. start?** by choosing .
- The mixer fills up with water.
6. Confirm **Mixer: drain?** by choosing .
- The mixer is drained.

Once the failure is eliminated, the message **Delete failure?** appears in the display. Confirm **Delete failure?** by choosing .

5.1.2.2 Temperature sensor, mixer

The **Temp. sensor, mixer warning** is shown in the display if the temperature sensor in the feeding box is defective or the temperature of the mixed feed in the feeding box drops below 0 °C.

You eliminate the failure as follows:

Use an ohmmeter to measure the voltage at the input of the temperature sensor on the board. Compare the measured value with the value in the circuit diagram provided, and if it is different, replace the temperature sensor.

5.1.2.3 Identification

Warning, identification appears in the display if animal identification is not working.

You eliminate the failure as follows:

Check the cables leading to the aerial. Repair any damage or replace the cables or aerials.

5.1.2.4 Incorrect ID

All CAN participants have a unique ID which cannot be changed. The ID is used to automatically check whether the right participant reports on the CAN address. If this is not the case, it is possible for the feeder and the participant to communicate, but there will be no proper data exchange. **Warning, Incorrect ID** appears in the display.

You eliminate the failure as follows:

Check all CAN addresses.

1. Switch on the feeder and hold down the  button until the setup menu appears in the display.
2. Choose **Stations > Feed > IFS-F singel** to go to the **CAN address** and check all CAN participants.
3. To exit the setup, press until the message **setup terminate?** appears. Confirm this by choosing .

If IDs have changed, e.g., for reasons of compatibility, you must perform an update for all CAN participants. To do this, use FlashManagerPlus.

5.1.2.5 Double address

If two or more participants are linked together in a bus system, it can occur that one CAN address is issued twice. **Warning, double address** appears in the display.

You eliminate the failure as follows:

1. Confirm **Warning, Address used twice** by choosing .
The CAN participant with the double address is displayed.
 2. Choose **> Setup > Stations > Feed > IFS-F single** to go to the **CAN address** submenu.
 3. Assign another, still available address to the CAN participant with the duplicate address.
For more information on assigning CAN addresses, see section **Setup > Address** (see **4.6.4.3 Feeder address** on page **62**).
- Note:** If possible, use an address from the standard range of numbers of the respective CAN participant.
4. Confirm your changes by choosing .
 5. To exit the setup, press until the message **setup terminate?** appears. Confirm this by choosing .
 6. Delete the warning on all feeders.

5.1.2.6 Unknown transmitters

The **Unknown transmitters warning** appears in your display:

- If a transmitter is detected by the identification unit for which no animal number has been assigned.
- If a transmitter number has been allocated to an animal number, but has still not been registered.

You eliminate the failure as follows:

1. Confirm **Unknown transmitters warning** by choosing .
2. In **No.**, you check the unknown transmitter number.
3. In **Number**, you check how many times the unknown transmitter number was identified.
4. In **Time**, you check when the transmitter was last recorded by the identification system.
5. Confirm **delete?** by choosing if you want to delete the transmitter number.

6. Confirm **Register** by choosing if you want to allocate the unknown transmitter number to an animal number.

5.1.2.7 Calibration

The **calibration warning** appears in your display if the last calibration was 120 days ago. You can see which components you have to calibrate.

You eliminate the failure as follows:

1. Calibrate all components shown in the display. (see section **Operation > Manual recalibration** in the operator's manual).
2. Confirm **delete warning** by choosing .

Note: If you delete the warning without calibrating, the message will appear again the next day.

5.1.2.8 Calibration scale

The **calibration scale warning** appears in your display if your calibration scale is not working.

ATTENTION Risk of malnutrition caused by incorrectly dispensed feed portions. Malnutrition can cause impaired growth and development, increased susceptibility to illness or even the death of your calves. You must ensure that the end user provides his/her calves with feed using an alternative method as long as the calibration scale is not working.

You eliminate the failure as follows:

1. Check whether the circuit board for the mixer scale is correctly plugged onto the main board of the feeder.
2. Check the cables which go to the calibration board as well as to the load rod for visible damage (for example, animal bites).
3. Check the load rod and the calibration unit of the mixer scale itself.

Note: The warning is automatically deleted once the failure has been rectified.

5.1.2.9 Double animal number

Warning, Double animal no. appears in your display if the same number was assigned twice during the fully automated registration process.

You change the double animal number as follows:

1. Confirm **Double animal no. warning** by choosing

The **Double** menu in animal control appears (see section **Operation > Animal control > Double** in the operator's manual).
2. In **No.**, the full transmitter number of the animal appears.
3. In **Animal no.**, change the automatically assigned number.
4. In **Time** and **Date**, check when the double animal number appeared.
5. Once you have changed the animal number, confirm **confirm?** by choosing .

Note: Your confirmation is not effective and the warning is not deleted until you have deleted the animal number.

5.1.2.10 Machine capacity

Warning, Machine capacity appears when there is no more storage space available for transmitter numbers.

Confirm **Machine capacity** by choosing in order to view detailed information.

- **50 animals only** means: No more free animal numbers are available.
- **Full transmitter memory** means: No more storage space available for further transmitter numbers.

You eliminate the failure as follows "50 animals only.":

1. Cancel one or more animals in the **Animal** menu.
2. Confirm Delete warning? by choosing .

You rectify the failure "transmitter storage full" as follows:

1. Choose  > **Animal management > Transmitters** to go to the **Edit** submenu.
2. Select the transmitter number to be deleted and confirm **delete** by choosing .

Note: You can only delete transmitter numbers from calves that are not registered (= status: available).

3. Confirm **delete warning?** by choosing .

5.1.2.11 Database

The **Database warning** appears in your display if there are errors in your database.

5.1.2.12 Checking the SD card (15-key hand terminal)

The **Check SD card** warning appears in your display:

- If data is to be saved manually, but no SD card is present.
- If data is to be saved manually, but the SD card is currently write-protected.
- If data is to be saved automatically but the SD card is full.
- If data is to be saved automatically but the SD card is currently write-protected.

5.1.3 Other failures and messages

5.1.3.1 Automatic feeder

5.1.3.1.1 Starting program

The message **High Vxx.xx starting program** appears when the control program of the automatic feeder starts.

Wait until the automatic feeder is ready to operate.

5.1.3.1.1 Initialization of the feeder

The message **first startup Press enter to start installation** appears in the display in the following cases:

- When the automatic feeder starts for the first time.
- If the computer card must be replaced due to a hardware defect.
- If the battery on the computer card is depleted.

Follow the instructions on the screen. The following steps can be performed in the course of the initialization:

- > Restoration of the last backup (if present).
- > Entry of the language for the user interface.
- > Entry of the current date and time.

5.1.3.1.1 NXP bootloader

The message **NXP Bootloader waiting for update** appears if the control program has started the NXP bootloader while updating the feeder version.

You eliminate the failure as follows:

Update the internal bootloader using FlashManagerPlus. Always wait until the internal bootloader has been updated before performing further steps.

5.1.3.1.1 Bootloader version obsolete

Bootloader version obsolete is shown if the automatic feeder's control program has an obsolete version of the internal bootloader. In this case, the application cannot be started.

You eliminate the failure as follows:

Confirm the message by choosing and update the internal bootloader using FlashManagerPlus.

5.1.3.2 Hand terminal

5.1.3.2.1 CAN bus off

If a short circuit or electromagnetic discharges negatively affect the CAN cable, the message **terminal Vxx.xx CAN bus off** appears in the display.

You eliminate the failure as follows:

Check the CAN bus for short circuits and other failures and correct them.

5.1.3.2.1 CAN bus heavy

The following failures trigger the message **terminal Vxx.xx CAN bus heavy** :

- Short circuit.
- Terminating resistor not set.
- Interruption of the data line.
- CAN cable incorrectly clamped on.
- No connection for automatic feeder control unit.

You eliminate the failure as follows:

- Check the CAN bus for short circuit.
- Check whether the terminating resistor has been properly set.

- Check whether the data line has been interrupted.
- Check whether the CAN cables are correctly connected.
- Check whether the data line is correctly wired and that the feeder control is working.



5.1.3.2.1 Waiting

The following failures prevent the hand terminal from initializing:

- The CAN bus address of the terminal is not the same as the one defined in setup of the of the automatic feeder.
- The feeder control is not active.

The message **terminal Vxx.xx waiting** appears.

You eliminate the failures as follows:

1. Start search mode: Press   when you switch on the feeder and keep this key pressed.
2. When the display reappears, you have to check whether the feeder control is working.

5.1.3.2.1 Searching

When the hand terminal is in search mode, the message **terminal Vxx.xx searching** appears.

You eliminate the failure as follows:

- Check whether the feeder is working.
- If the message is not automatically hidden in about ten seconds, you must check the feeder control.

5.1.3.3 Bootloader

5.1.3.3.1 Waiting for update



The following failures trigger the message **bootloader Vxx.xx waiting for update**:

- The automatic feeder's control program is not able to run.

Update the program using FlashManagerPlus.

Note: With bootloader version 02.04 and higher, you can also update the program using an SD card.

- The bootloader was (accidentally) activated during switching on.

If the bootloader was accidentally started during the start of the automatic feeder by pressing and holding  , you have to restart the automatic feeder.

5.1.3.3.1 Flash programming

The message **bootloader Vxx.xx flash programming** appears when the program is updated.

Wait until the update has been completed.

5.1.3.3.1 Starting program

The message **bootloader Vxx.xx starting program** appears when the bootloader of the automatic feeder starts.

Wait until the program has started.

5.2 Service messages

A service message appears in the automatic feeder display every 4 months. This message indicates the maintenance (rule service) that must be performed. Compliance with these maintenance intervals is the only way to ensure the long life and reliability of the automatic feeder.

Go to **Setup > Service > Last service** > and check when the last rule service was performed or go to **Setup > Service > Next service** > to determine when the next rule service is due.

The following rule services (RS) have been defined:

- RS1 must be performed every 4 months.
- RS2 must be performed every 12 months.
- RS3 must be performed every 36 months.

5.3 Diagnosis

The **Diagnosis** menu helps you to find failures in the event of technical problems. You can reach this menu via . A diagnosis can be performed for the following parts of the automatic feeder:

- Valves
- Motors
- Heater
- Sensors

- Control
- Version
- Setup
- Software

5.3.1 Checking valves/motors

In this menu, you check actuators (valves and motors) and their actuation.

5.3.1.1 Valves

Check the valves as follows:

1. Choose  > **Diagnosis** to go to the **Valves** submenu.
2. Confirm **Bo. water open?** by choosing in order to open the water valve. The valve remains open as long as you hold down .
3. Check whether the valve opens.

5.3.1.2 Motors

Check the motors as follows:

1. Choose  > **Diagnosis** to go to the **Motors** submenu.
2. Confirm **Mixer start?** by choosing in order to start the mixer.
3. Confirm **Powder start?** by choosing in order to start the powder mixer.
4. Confirm **Feeding pump start?** by choosing in order to start the feeding pump.

5.3.2 Checking heater

In this menu, you check the boiler heater.

Check the boiler heater as follows:

1. Choose  > **Diagnosis** to go to the **Heating** submenu.
2. Confirm **switch on?** by choosing .
3. In **Boiler**, you check the temperature.
4. If you hold down in **switch on?**, the boiler is heated up. If the temperature rises, the heater is working.

5.3.3 Checking sensors

In this menu, you check the sensors of the following components:

- Bar electrode.
- Button for the manual feeding pump (active/inactive).
- Mixer and boiler (temperatures of the liquids in the boiler and in the feeding box).

5.3.3.1 Bar electrode

Check the electrodes as follows:

1. Choose  > **Diagnosis > Sensors** to go to the **EI. bar** submenu.
2. In the right-hand column, check the status (**free** or **covered**).
3. Confirm **EI. bar** by choosing .
- 3.1 In **Status**, check the status (**free** or **covered**).
- 3.2 Confirm **Boiler water: start?** by choosing .

The electrode is triggered if **water** is dispensed into the feeding box.

- 3.3 Confirm **Mixer: drain?** by choosing in order to evacuate the liquid.

5.3.3.2 Button for the manual feeding pump

Check the button as follows:

1. Choose  > **Diagnosis > Sensors** to go to the **MP button** submenu.
2. In the right-hand column, check the status (**active** or **inactive**).

5.3.3.3 Temperature in the mixer and boiler

Check the temperature of the liquid in the mixer or boiler as follows:

1. Choose  > **Diagnosis > Sensors** to go to the **Boiler** or **Mixer** submenu.
2. Check the temperature in the right-hand column.

5.3.4 Checking boxes

In this menu, you check the feeding box(es).

- > You check whether the identification of the feeding box works.

- > You can open the feeding box valve.
- > In the display, you can view the control unit assigned to the feeding box.



You check the identification of a feeding box as follows:

1. Choose  > **Diagnosis > Station > Feed** to go to the **Feed-station 1** or **Feed-station 2** submenu.
2. To check the identification (aerial test), hold a transmitter near the aerial.
3. In **No. ƒ**, you check the number of transmitter number.

If the transmitter number is not recognized, proceed as follows:

- > Check in the setup whether the correct identification system is configured.
- > Check the data lines between aerial and automatic feeder for damage.
- > Check the setup for the allocation of the box that is causing identification problems.

You check the feeding box valve as follows:

1. Choose  > **Diagnosis** to go to the **Valve** submenu.
2. Confirm **open?** for the respective valve by choosing .
3. Check whether the valve opens.

5.3.5 Control

In this menu, you check the following failures:

- How often the automatic feeder was without power (**power failures**).
Note: Switching on and off are also considered to be power failures.
- How often the feeder control unit had to be restarted after a program error (**Reset**).
- How often the connection to the **terminal** was faulty.
- How often an error occurred in connection with the **database**.
- How often the automatic feeder received no response from the **identification** system.
- How often the minimum temperature in the boiler was not met (**heating**).
- How often the water test was negative (**water shortage**).
- How often the **heating** function was faulty.

- How often failures occurred during automatic cleaning of the mixer (**cleaning**).
- How often implausible values were reported by the **temperature sensors** in **Boiler** and **Mixer**.
- How often the **temperature** of the boiler water was **too high**. e.g., if the automatic feeder was with charged with hot water.
- How often a feeding program not permitted for the device was installed (**incorrect ID**).
- How often the automatic feeder could not switch to automatic mode because, for example, the liquid and powder feed components were not calibrated (**calibration**).
- How often the same address has been assigned in the CAN bus to devices (**double address**).
- How often **Unknown transmitters** have been detected by the identification system.
- How often it has been indicated that an animal number has already been assigned (**double animal no.**).
- How often the test of the **circulation pump** was negative.

You check the failures as follows:

1. Choose  > **Diagnosis** to go to the **Control** submenu.
2. Select the failure that has occurred.
 - In **Number**, you check how many times the failure occurred.
 - In **since**, you check when the entries were deleted the last time.
 - In **last on** or **last at** you can determine the day on which or the time at which a certain event last occurred.
3. Confirm **delete?** by choosing in order to delete the failure message.

5.3.6 Version

In the **Version** menu, you can check version numbers. The following units have a version number:

- Feeder
- Processor

- Terminal
- Identifications at existing feeding boxes.

Check the version as follows:

1. Choose  > **Diagnosis** to go to the **Version** submenu.
2. Go to the desired submenu and read the version number.

5.3.7 Setup

You can only view the settings in this menu. To make changes, you must open the setup menu (see 4.6 Setup on page 59 and following pages).

You check the setup settings as follows:

1. Choose  > **Diagnosis** to go to the **Setup** submenu.
2. Go to the desired submenu and check the settings.

5.3.8 Software

This menu is only intended for the manufacturer's development department.

6 Appendix

Note: The following checklists and overviews also include additional equipment. If this equipment is not present in your specific case, skip the irrelevant items on the list.

6.1 Checklist for initial startup and restart

Note: Before each initial startup or restart of the automatic feeder, you must carefully read and observe the operating manual, particularly the safety information.

Initial startup and restart		OK?
1.	Inform the end user that the automatic feeder must be installed in a frost-protected place or fitted with frost protection equipment.	<input type="checkbox"/>
2.	Tell end users that the automatic feeder must be protected from rain and moisture.	<input type="checkbox"/>
3.	Tell the end user that the water should be of drinking water quality. Excessive scales and/or iron and/or manganese concentrations may cause premature wear.	<input type="checkbox"/>
4.	Tell end users that the feeder and cables are to be protected against exposure to sunlight.	<input type="checkbox"/>
5.	Set up the automatic feeder on an even surface.	<input type="checkbox"/>
6.	Ground the automatic feeder.	<input type="checkbox"/>
7.	Connect water supply.	<input type="checkbox"/>
8.	Install feeding box and feeding station.	<input type="checkbox"/>
9.	Connect aerials.	<input type="checkbox"/>
10.	⊕ Install concentrate station (including aerials) and fill concentrate container.	<input type="checkbox"/>
11.	Install suction hoses.	<input type="checkbox"/>
12.	Install protective grid for the powder hopper attachment.	<input type="checkbox"/>
13.	Fill up MP container.	<input type="checkbox"/>
14.	Check switch setting for heating cable, vapor barrier and feeding box heating (0 in summer).	<input type="checkbox"/>
15.	Connect power supply.	<input type="checkbox"/>
16.	Switch on automatic feeder.	<input type="checkbox"/>
17.	Fill boiler with water.	<input type="checkbox"/>
18.	Set the set and minimum temperature of the heating (in menu, device data > portion).	<input type="checkbox"/>
19.	Check the operating mode.	<input type="checkbox"/>
20.	Check time/date.	<input type="checkbox"/>
21.	Define box parameters.	<input type="checkbox"/>

22.	⊕ Assign function keys	<input type="checkbox"/>
23.	Specify animal list.	<input type="checkbox"/>
24.	⊕ Check calibration scale.	<input type="checkbox"/>
25.	Calibrate feed components and ⊕detergent.	<input type="checkbox"/>
26.	Check or set cleaning settings.	<input type="checkbox"/>
27.	Perform cleaning.	<input type="checkbox"/>
28.	Read and create transmitters	<input type="checkbox"/>
29.	Register animals.	<input type="checkbox"/>
30.	Enter correction days.	<input type="checkbox"/>
Setup		OK?
1.	Switch off automatic feeder using the control switch and switch it on again; while doing this press and hold  .	<input type="checkbox"/>
2.	Check the following settings:	
2.1	Language	<input type="checkbox"/>
2.2	Check time/date, set if necessary	<input type="checkbox"/>
2.3	Machine	
2.3.1	Assign number and address.	<input type="checkbox"/>
2.3.2	Determine base size.	<input type="checkbox"/>
2.3.3	Activate heating yes/no – mechanical relay.	<input type="checkbox"/>
2.4	Equipment	
2.4.1	⊕Mixer drain present yes/no.	<input type="checkbox"/>
2.4.2	⊕ Additional dispenser 1 powder or liquid present yes/no.	<input type="checkbox"/>
2.4.3	⊕ Detergent pump present yes/no.	<input type="checkbox"/>
2.4.4	Temperature sensor, mixer present yes/no.	<input type="checkbox"/>
2.4.5	⊕ Calibration scale present yes/no.	<input type="checkbox"/>
2.5	Identification	
2.5.1	Set type.	<input type="checkbox"/>
2.5.2	Set squelch value.	<input type="checkbox"/>
2.6	Boxes:	
2.6.1	Activate internal feeding box(es), controlled by feeder.	<input type="checkbox"/>

2.6.2	⊕ Configure IFS concentrate station 1(...). Select concentrate type and automatic concentrate feeder type. Assign CAN bus address: put IFS (concentrate station) into search mode for this and then via search ? Allocate address.	<input type="checkbox"/>
2.7	Terminal:	
2.8	Communication:	
2.8.1	Institut yes/no	<input type="checkbox"/>
2.8.2	Configure gateway, parameters.	<input type="checkbox"/>
Device data		OK?
1.	New installation.	<input type="checkbox"/>
2.	Operating modes:	
2.1	Set rationed or ad lib mode.	<input type="checkbox"/>
3.	Feeding box:	
3.1	Drink-out time and pause time.	<input type="checkbox"/>
Calibration		OK?
1.	MP	<input type="checkbox"/>
2.	Boiler water	<input type="checkbox"/>
3.	⊕ Additive 1	<input type="checkbox"/>
4.	⊕ Detergent	<input type="checkbox"/>
5.	⊕ Concentrate stations.	<input type="checkbox"/>
6.	⊕ Settings for automatic calibration of MP/water.	<input type="checkbox"/>
Register		OK?
1.	Aerial test	<input type="checkbox"/>
2.	Set the scheme for the transmitter number assignment: consecutive, automatic.	<input type="checkbox"/>
3.	Read transmitter numbers.	<input type="checkbox"/>
4.	Set registration mode: no, automatic, available transmitter numbers.	<input type="checkbox"/>
5.	Register animals.	<input type="checkbox"/>

Plans		OK?
Feed		
1.	Feeding plans	<input type="checkbox"/>
2.	Concentrate plans	<input type="checkbox"/>
3.	Quantity limitation: check minimum saved amount/maximum saved amount.	<input type="checkbox"/>
4.	+ Weaning	<input type="checkbox"/>
+ Concentrate		
1.	Concentrate plan	<input type="checkbox"/>
2.	Portion size	<input type="checkbox"/>
3.	Quantity limitation: check minimum saved amount/maximum saved amount.	<input type="checkbox"/>
4.	Activate accustoming quantity yes/no.	<input type="checkbox"/>
4.1	Check amount/threshold and, if necessary, set.	<input type="checkbox"/>
Change date of individual animals		OK?
1.	Group	<input type="checkbox"/>
2.	Feed	<input type="checkbox"/>
3.	Concentration	<input type="checkbox"/>
4.	+ Concentrate	<input type="checkbox"/>
5.	+ Additive 1	<input type="checkbox"/>
6.	Weight	<input type="checkbox"/>
7.	Plan day (correction days)	<input type="checkbox"/>
Cleaning		OK?
1.	Settings:	
1.1	Temperature, cleaning water	<input type="checkbox"/>
1.2	Detergent amount	<input type="checkbox"/>
1.3	Clean teat	<input type="checkbox"/>
2.	Mixer:	<input type="checkbox"/>
3.	Cleaning circuit	<input type="checkbox"/>
4.	Suction hose	<input type="checkbox"/>

6.2 Automatic feeder material list

The materials used in the automatic feeder include:

- Brass, Enzidor®
- Silicon carbide
- Carbon
- V2A, V4A
- Plastics: PET, TPE, silicon, PVC, NBR, ABS, PUR
- Viton
- Vulcanized fiber, graphitized
- Rubber
- Bronze

6.3 Automatic feeder shutdown checklist

	ok?
Empty and clean the milk powder hopper.	<input type="checkbox"/>
Close the cable inlets of the antennas by means of blind plugs. Moisture may penetrate into the control unit if the inlets are not closed.	<input type="checkbox"/>
Run cleaning cycle	<input type="checkbox"/>
Drain water from boiler. Disconnect the water connection and turn the valve off. Remove the water hose between the water solenoid valve and the boiler and open the vent screw on the cover of the boiler to allow the water to flow out. Once the boiler is completely drained, connect the water hose and tighten the vent screw.	<input type="checkbox"/>
Disconnect the milk hose and close the milk connection	<input type="checkbox"/>
Drain the water from the solenoid valves and the volume regulator. (In case of frost risk!)	<input type="checkbox"/>
Pull the mains plug.	<input type="checkbox"/>
Basic cleaning of the powder container and dosing unit	<input type="checkbox"/>
Store the device in a dry and, if possible, frost-protected place	<input type="checkbox"/>

6.4 CAN bus addresses

Standard addresses

The following chart shows an example of address assignment based on default values. On the following page, you can assign completely customized addresses. Copy the template if needed.

Note: You can assign a number only once.

Note: If possible, do not change the standard addresses.

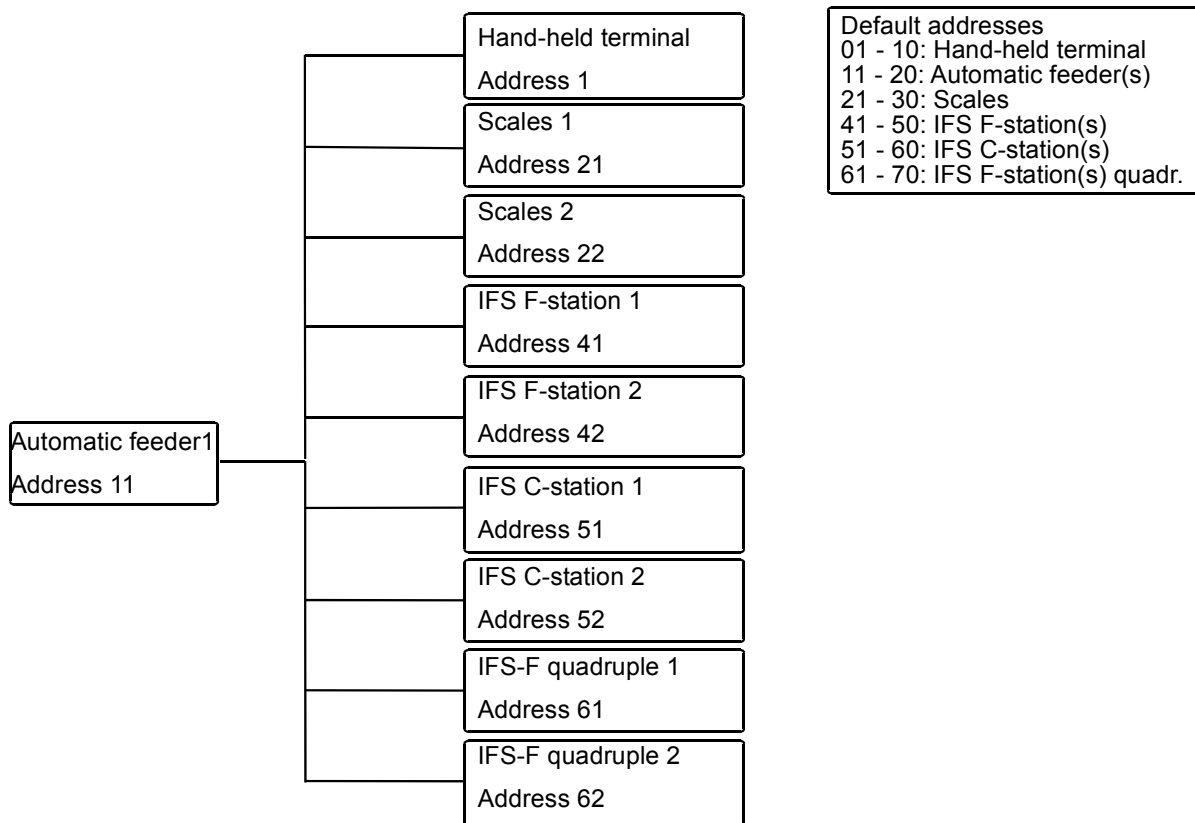

Template for individual address assignment

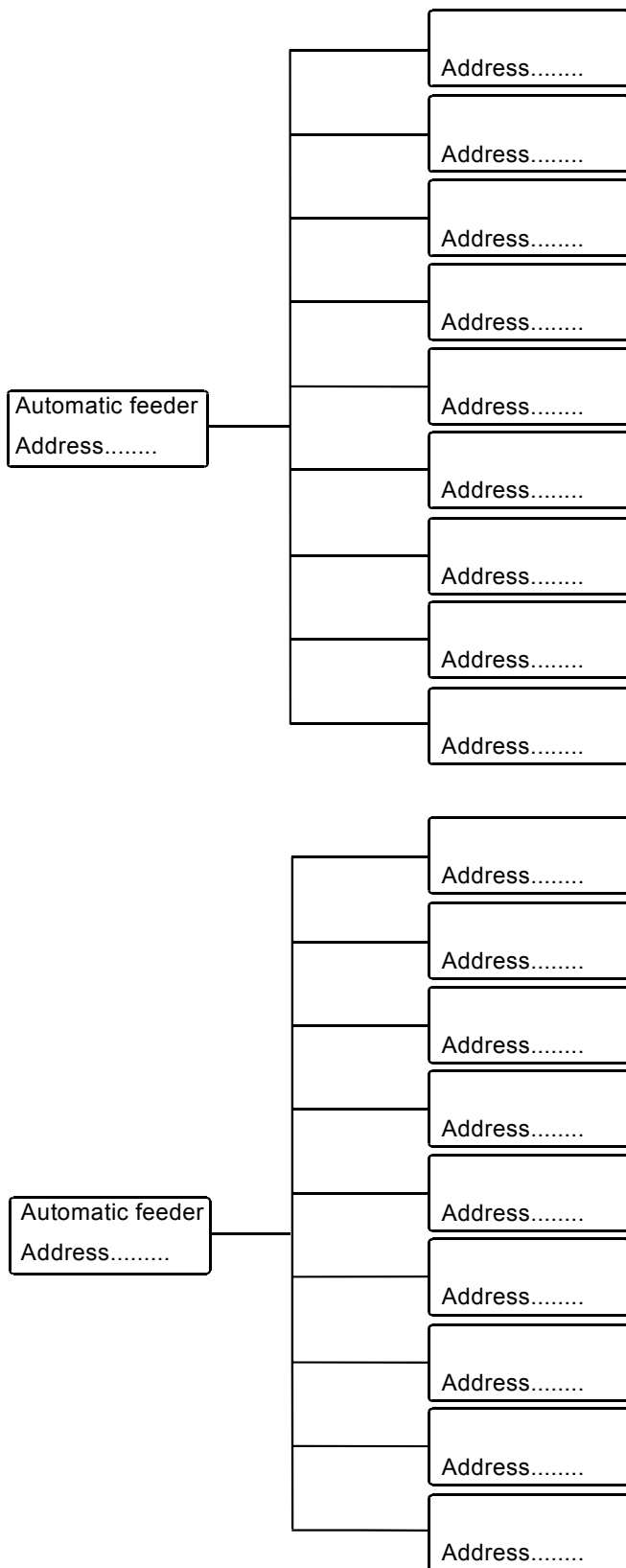

Default addresses
01 - 10: Hand-held terminal
11 - 20: Automatic feeder(s)
21 - 30: Scales
41 - 50: IFS F-station(s)
51 - 60: IFS C-station(s)
61 - 70: IFS-F quadruple

6.5 Test components must undergo metrological testing in accordance with national regulations

All electrical components must be checked regularly for electrical safety in accordance with the intervals and test methods defined in the national regulations.

If any failures or damage are detected during the inspection, the faulty components have to be replaced before the automatic feeder can be used again.