

Original Service Manual

Automatic calf feeder
Type COMPACT smart Powder
Program version 1.01 and higher

TAP5-CS1-25



Table of contents

1	Introduction	7
1.1	Automatic feeder versions	7
1.2	Automatic feeder overview	8
1.2.1	Front and right side view of the automatic feeder	8
1.2.2	Left side view of the automatic feeder	10
1.2.3	Rear view of the automatic feeder	11
1.2.4	Boiler with heating circuit	12
1.3	Technical data	12
1.3.1	Electrical connection	12
1.3.2	Dimensions of the automatic feeder	13
1.3.3	Weight	13
1.3.4	Water connection	13
1.3.5	Milk powder container	13
1.3.6	Number of feeding stations and animals	14
1.4	Disposal	14
1.5	Symbols and abbreviations	14
1.5.1	Symbols	14
1.5.2	Abbreviations	15
2	Important safety information	17
2.1	Intended use	17
2.2	Necessary qualifications	17
2.3	Residual risk which can arise from the automatic feeder	17
2.3.1	Hazards to health caused by the automatic feeder	17
2.3.2	Material damage caused by the automatic feeder	19
2.4	What hazard warnings are provided?	19
2.4.1	Components of a hazard description	19
2.4.2	Hazards causing death or injury	20
2.4.3	Material damage	20
2.5	Safety labels on the automatic feeder	21
2.5.1	Warning signs on the machine	21
2.6	Safety equipment on the automatic feeder	23
3	Commissioning	27
3.1	Setting up the automatic feeder	27
3.2	Electrical connection provided by the customer	28
3.3	Water connection	28
3.4	Installing feeding stations	29
3.4.1	Installing feeding station	29
3.4.2	Installing stand partition	30
3.5	Connecting antennas	30
3.5.1	Installation of antennas	30
3.5.2	Squelch values and identification ranges	31
3.5.3	Connecting antenna cables	32
3.5.4	Connecting Ethernet cables	33
3.6	Installing the safety grid for the powder hopper attachment	35
3.7	Switching on the condensation prevention heating for powder discharge and frost protection equipment	35
3.8	Filling the powder container	36
3.9	Installing the external detergent supply line (option)	36
3.10	Switching on the automatic feeder	37

3.11	Filling the boiler	37
3.12	Reconfiguring everything	37
3.13	Setting offline mode	38
3.14	Setting the portion	38
3.15	Setting operating modes	39
3.16	Checking and setting the time/date	39
3.17	Drain time station parameters.	39
3.18	Function keys	40
3.19	Animal list	40
3.20	Checking the components	40
3.21	Calibrating feed components	40
	3.21.1 Manually calibrating liquid and powder components.	40
	3.21.2 Automatic calibration	45
3.22	Checking or setting cleaning settings	45
3.23	Cleaning the automatic feeder	46
3.24	Reading in and creating transmitters	46
3.25	Registering animals	46
3.26	Entering correction days.	46
4	Programming and control	47
4.1	Hand terminal	48
	4.1.1 The 15-key hand terminal	48
	4.1.2 Auto LED	50
4.2	Offline mode	50
4.3	Automatic mode	51
4.4	Menu structure	51
	4.4.1 Symbols.	52
	4.4.2 Navigation	53
	4.4.3 Menus	54
4.5	Device data.	56
	4.5.1 Operating modes.	57
	4.5.2 Checking and setting the time/date	58
	4.5.3 Setting the portion	58
	4.5.4 Drain time station parameters	61
	4.5.5 Function keys	61
	4.5.6 Animal list	62
	4.5.7 Backing up and restoring data.	65
	4.5.8 New installation	67
	4.5.9 CalfCloud.	68
4.6	Software update	69
5	Setup	71
5.1	Overview of the Setup menus.	72
5.2	Language	73
5.3	Time/date	73
5.4	Machine	74
	5.4.1 Feeder type	74
	5.4.2 Feeder number	74
	5.4.3 Feeder address	75
	5.4.4 Feeder operating mode	75
	5.4.5 Base size	75
	5.4.6 Heating	76
	5.4.7 Boiler valve	76
5.5	Equipment.	76
	5.5.1 Mixer drain.	76

5.5.2	Additive dispenser	76
5.5.3	Detergent pump	76
5.5.4	Circulation valve	77
5.5.5	Mixer temperature sensor	77
5.6	Identification	77
5.7	Calibration scale	78
5.8	Stations	78
5.8.1	Feed	78
5.9	Terminal	79
5.9.1	Address	79
5.9.2	Contrast	79
5.9.3	Sleep mode	79
5.10	Communication	80
5.10.1	Printer	80
5.10.2	Gateway	80
5.10.3	MultiReader	80
5.10.4	CAN analyzer	81
5.10.5	Network configuration	81
5.10.6	Cloud	81
5.10.7	Restart	82
6	Transmitter and animal management	83
6.1	Managing transmitters	83
6.1.1	Basics	83
6.1.2	Creating transmitter numbers	84
6.1.3	Assigning animal numbers	85
6.1.4	Editing transmitter or animal numbers	86
6.1.5	Changing the animal number	86
6.1.6	Deleting the transmitter number when canceling an animal's registration	87
6.1.7	Retrieving transmitter statistics	87
6.2	Registering animals	88
6.2.1	Registering animals manually	88
6.2.2	Registering animals automatically	88
6.3	Canceling animals or animal groups	90
6.3.1	Canceling an individual animal's registration	90
6.3.2	Canceling a group registration	91
6.3.3	Canceling the registration of weaned animals	91
6.4	Transferring animal registrations	91
7	Shutting down and recommissioning the automatic feeder	93
7.1	Shutdown	93
7.1.1	Temporary shutdown	93
7.1.2	Permanent shutdown	96
7.2	Recommissioning	96
7.2.1	Recommissioning after temporary shutdown without change of location	96
7.2.2	Recommissioning after long-term shutdown or change of location	98
7.2.3	Recommissioning after processor card replacement	98
8	Faults and warnings	101
8.1	Faults	101
8.1.1	Calibration scale	101
8.1.2	Heating	102
8.1.3	Temperature too high	102
8.1.4	Boiler not filled	103
8.1.5	Water shortage	103

8.1.6	Mixer emptying	104
8.1.7	Heating	105
8.1.8	Boiler temperature sensor	106
8.1.9	Calibration	107
8.1.10	Box/drain valve	107
8.1.11	Uncontrolled output	108
8.2	Warnings	109
8.2.1	Mixer emptying	109
8.2.2	Mixer temperature sensor	110
8.2.3	Identification	111
8.2.4	Incorrect ID	111
8.2.5	Address used twice	111
8.2.6	Unknown transmitters	112
8.2.7	Calibration	112
8.2.8	Calibration scale	113
8.2.9	Double animal number	113
8.2.10	Machine capacity	114
8.2.11	Check SD card	115
8.3	Other faults and messages	115
8.3.1	Automatic feeder	115
8.3.2	Hand terminal	115
8.3.3	Bootloader	117
8.4	Service messages	117
8.4.1	Service work	118
8.5	Diagnosis	119
8.5.1	Checking valves/motors	119
8.5.2	Checking the heating	120
8.5.3	Checking sensors	120
8.5.4	Checking stations	121
8.5.5	Control	122
8.5.6	Version	123
8.5.7	Setup	123
8.5.8	Software	124
8.5.9	Remote maintenance	124
9	Appendix	125
9.1	Checklist for commissioning and recommissioning	125
9.2	Automatic feeder material list	130
9.3	Automatic feeder shutdown checklist	131
9.4	Standard feeding plans	132
9.5	CAN bus addresses	134
9.6	Measuring the components using test equipment in accordance with national regulations	136

1 Introduction

This operating manual enables you to operate this automatic feeder machine safely as intended.

- > Have the end user provide you with the operating manual for the automatic feeder, the operating manuals of all additional equipment to be connected and the safety data sheets for cleaning agents.
- > Carefully read all operating manuals and safety data sheets before starting up the automatic feeder for the first time or restarting it.
- > Observe all of the warnings and safety instructions in these operating manuals and safety data sheets at all times.

1.1 Automatic feeder versions

The following automatic feeder versions are available:

- **Powder** - for the use of milk substitute (MP).
- **Combi** - for the use of milk substitute and fresh milk.
- **Fresh milk** - for the use of fresh milk.

All automatic feeder versions can be equipped with a variety of pieces of peripheral equipment and options.

1.2 Automatic feeder overview

1.2.1 Front and right side view of the automatic feeder

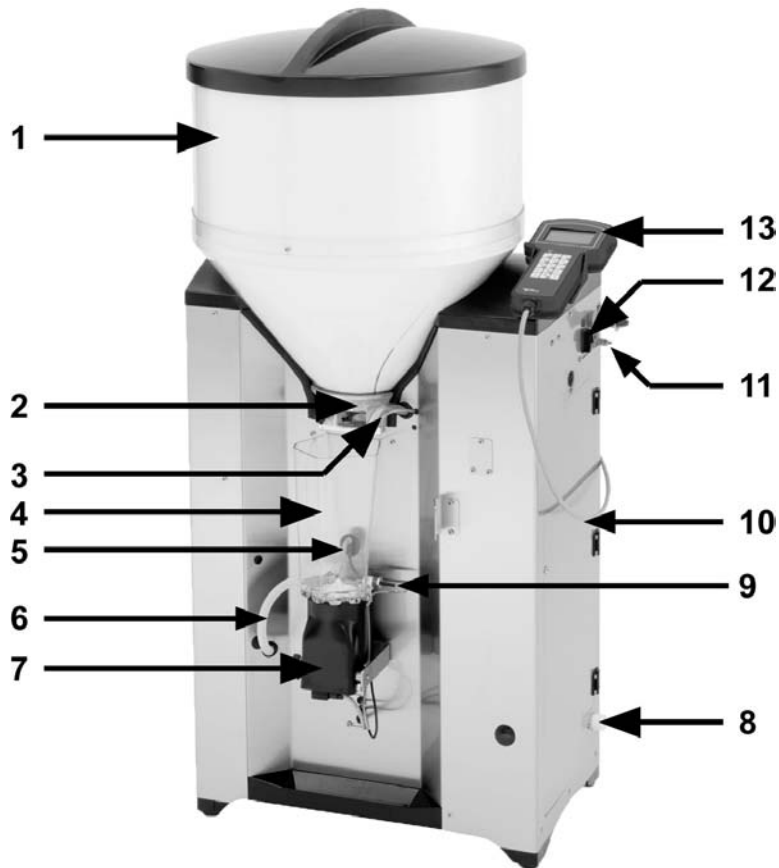

- | | |
|---|----------------------------|
| 1 Milk powder container | 8 Water connection |
| 2 Milk powder discharge | 9 Temperature sensor |
| 3 Water supply | 10 Right door |
| 4 Mixer jar | 11 Ground connection screw |
| 5 Rod electrode | 12 Control switch |
| 6 Hose connection from mixer to station valve | 13 Hand terminal |
| 7 Mixer motor | |

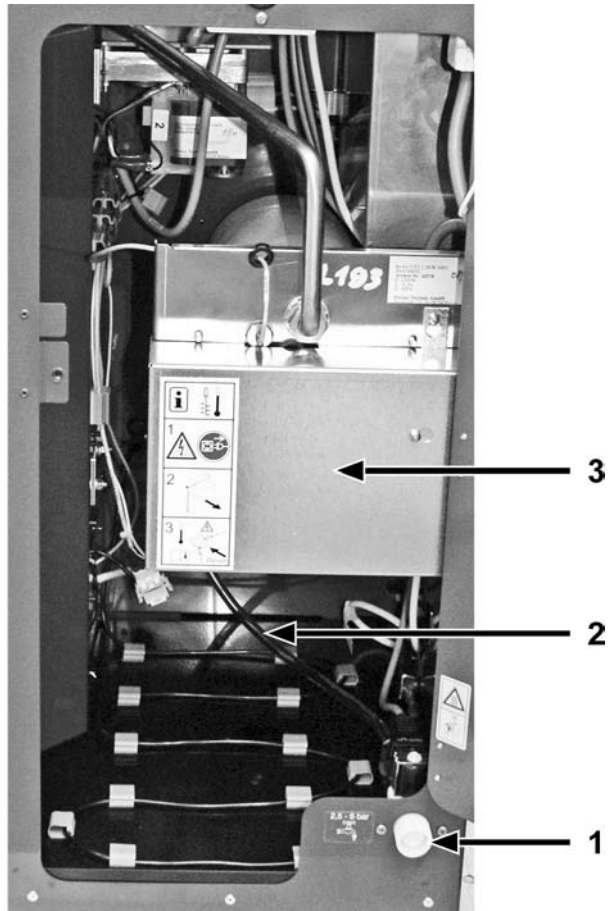
Behind right side door

- 1 Water supply
- 2 Water supply line to boiler container
- 3 Boiler container

1.2.2 Left side view of the automatic feeder

The name plate is located above the left side door on the outside of the automatic feeder. It contains information about the manufacturer, type and number of the automatic feeder, information about connecting the feeder to the power supply as well as its certification. An example of a name plate is shown below.

Name plate



- 1 Name and address of the manufacturer
- 2 Type and number of the automatic feeder
- 3 Information on the connection to the power supply
- 4 The automatic feeder's certifications

Behind the left side door

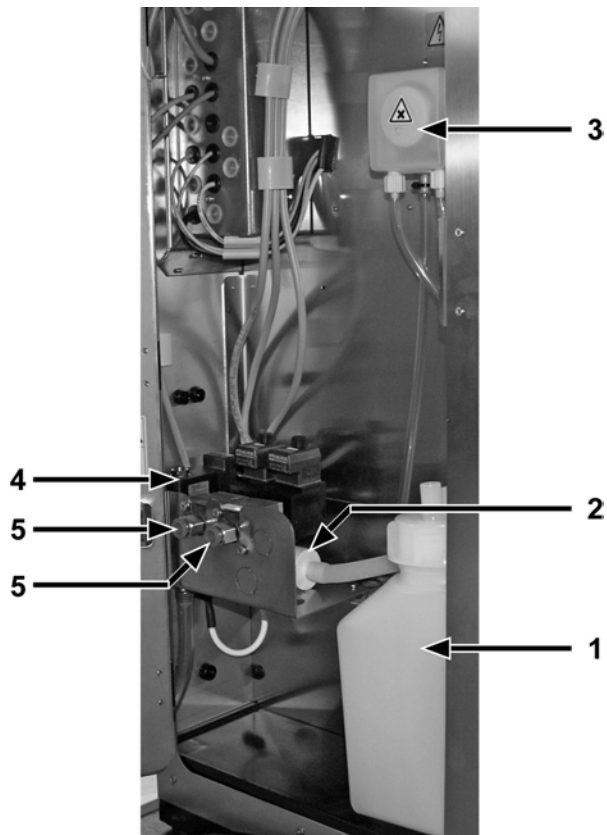

- 1 Storage container for detergent (optional)
- 2 Feeding pump
- 3 Detergent dosing pump (optional)
- 4 Mixer drain valve
- 5 Feeding box valve(s)

1.2.3 Rear view of the automatic feeder

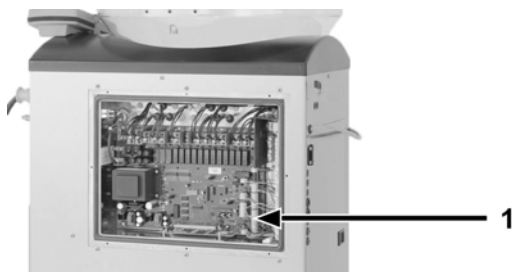

- 1 Processor and power circuit board

1.2.4 Boiler with heating circuit

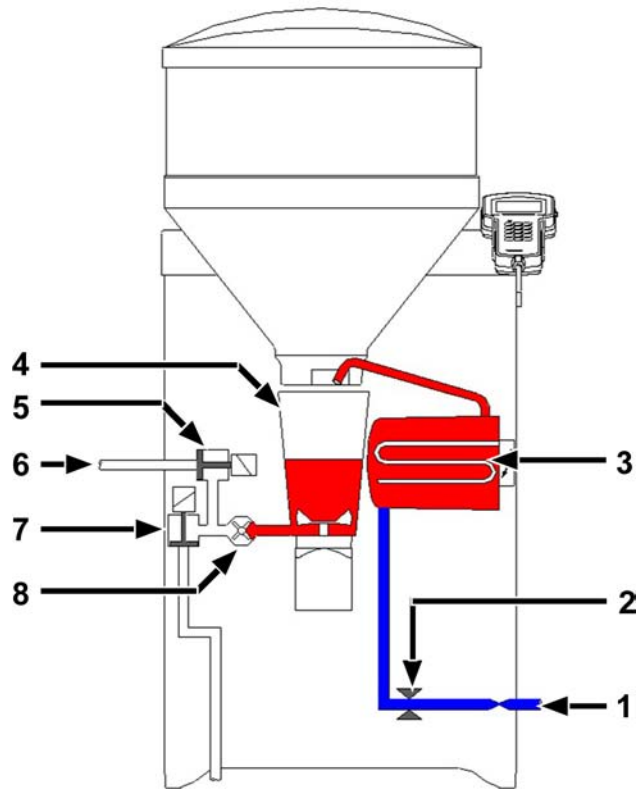

- | | | | |
|---|--------------------------------|---|--|
| 1 | Hose connection for water pipe | 5 | Feeding box valve |
| 2 | Boiler water valve | 6 | Hose connection between feeding box valve and teat |
| 3 | Boiler | 7 | Mixer drain valve |
| 4 | Mixer | 8 | Feeding pump |

1.3 Technical data

1.3.1 Electrical connection

Note: The specifications for the electrical connection to your automatic feeder are on its name plate above the left side door on the outside (see **1.2.2** Left side view of the automatic feeder, page **10**).

1.3.2 Dimensions of the automatic feeder

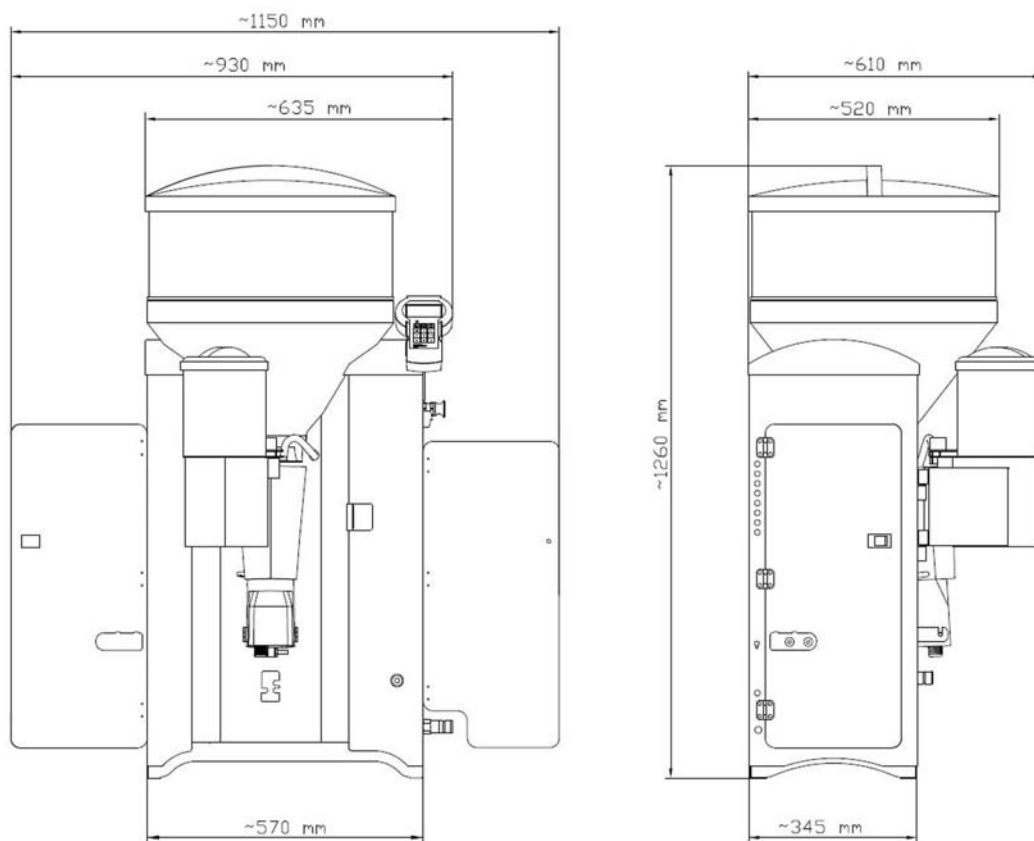

Depth when the fly screen door is opened ~ 690 mm

1.3.3 Weight

Approx. 80 kg.

1.3.4 Water connection

Water is connected via a 3/4 inch hose and with a 3/4 inch screwed connection.

ATTENTION The water should be of drinking water quality. Please bear in mind that high calcium, iron and manganese concentrations cause premature wear. In these cases it makes sense to install appropriate filtration systems.

1.3.5 Milk powder container

The milk powder container with attachment holds approximately 35 kg of milk substitute.

1.3.6 Number of feeding stations and animals

Feeding stations	Calves per feeding station	Calves per device
Max. 2	Max. 25	Max. 50

1.4 Disposal

All components, liquids and solids must be disposed of in compliance with the official local regulations for waste prevention and appropriate waste recycling or disposal which apply in your country. Also observe the relevant safety data sheets.

1.5 Symbols and abbreviations

1.5.1 Symbols



Optional: A white plus sign on a black background indicates that optional functions or equipment are being described.

1.5.2 Abbreviations

Abbreviation	Meaning
abs.	Absolute
add. disp.	Additive dispenser
Ad lib	Ad lib
bo	Boiler
C	Concentrate
Clean teat	Clean teat
clo.?	Close?
conc./concentr.	Concentration
det. pump	Detergent pump
dos.	Dosage
dra.v. teat	Drain via teat
Drnk spd.	Drinking speed
dr. time	Drain time
EI	Electrode
electrol.	Electrolyte
f	40FIT period
F	40FIT feeding principle
fd.sensor	Feeding sensor
feed.pump	Feeding pump
gradient	Gradient control
gr. A (B)	Group A (B)
ho.	Hose
IFS KF	Intelligent feeding station concentrate
IFS TR	Intelligent feeding station feed
Incr./Red.	Increase/reduction
IV	Interval feeding program
MAP	Manual feeding pump
max	Maximum
Min. temp.	Minimum temperature
mixer cl.	Cleaning the mixer
mixer dr.valve	Mixer drain valve
mix. full	Mixer full
MP	Milk substitute
n.	Not
No.	Number
out. pause	Dispensing pause
P 1-5	Periods 1 - 5
R	rationed feeding principle
rel.	Relative
save amt.	Amount saved up
servo	Servo control
sw.off del.	Switch-off delay
sw. on del.	Switch-on delay
Temp.	Temperature
TR	Feeding box
w/add. or w/addiv.	With additive
w/o add. or w/o add.	Without additive

w/o entitlement	Without entitlement
water bo.	Boiler water
w. entitle.	With entitlement

2 Important safety information

This chapter outlines:

- The hazards caused by your automatic feeder and how to avoid them.
- The safety labels attached to the automatic feeder and what they mean.
- How to safely install the automatic feeder.

The automatic feeder is state of the art and is produced in compliance with recognized safety regulations. However, hazards and adverse effects may arise when using it. Both warning signs directly on the automatic feeder and warning notices in this manual provide warning of these hazards.

2.1 Intended use

The automatic feeder may only be used to prepare, heat, and dispense liquid feeds, for example milk, for calves.

2.2 Necessary qualifications

Only trained service technicians are authorized to install the automatic feeder, put it into service and perform maintenance and repairs on it.

Service technicians are specialists with the appropriate qualifications. They are able to assess the work assigned to them and detect potential risks on the basis of their technical training as well as their knowledge of the relevant standards. They are familiar with the relevant accident prevention regulations, generally accepted safety regulations and country-specific standards and provisions.

2.3 Residual risk which can arise from the automatic feeder

2.3.1 Hazards to health caused by the automatic feeder:

⚠ WARNING The automatic feeder is electrically powered. You must observe the general precautions for handling electrical equipment:

- Read the operating manual before operating the automatic feeder.
- Keep children away from the automatic feeder.
- Do not touch any moving parts of the automatic feeder, for example the mixer blades.

- Only use genuine spare parts from the manufacturer.
- Turn off the automatic feeder and disconnect the power plug before carrying out any maintenance or cleaning work on the automatic feeder.
- If the end user intends to operate the automatic feeder outside of closed spaces, inform the user that he/she must protect the automatic feeder from rain and moisture, for example with a roof.
- The following specific hazards are associated with the automatic feeder's electrical system:
 - **Electrical breakdown.** If there is an electrical or voltage breakdown, electric current flows through parts of the automatic feeder that are normally insulated. Touching the unit can cause a fatal electric shock. The automatic feeder must be checked regularly for electrical safety in compliance with national regulations (repeated inspection). Make sure that a 30 mA residual current device (RCD) is installed.
 - **Short circuit, indirect contact.** If there is a short circuit, current at many times the level of the operating current can flow. Touching the unit can cause a fatal electric shock. Make sure you install a fuse (provided by the customer) corresponding to the rating on the name plate and a 30 mA residual current device (RCD) in compliance with local regulations.
- The solenoid valves and the pipes to the valves can reach temperatures of up to 70°C. Touching them can cause burns. Do not touch the solenoid valves and pipes during operation.
- Liquid at temperatures of up to 70°C can spray out of the pipes to the valves. This can cause scalding. Do not touch the pipes during operation. Carry out the recommended maintenance on the hoses.
- The mixer and powder supply may start up unexpectedly if a calf which is entitled to feed approaches the unit. This can crush or chop off fingers or hands. Never reach into the area of the mixer or powder supply while the automatic feeder is in operation. Only use the scraper supplied to clean the powder discharge opening.
- **Poisoning.** Additives that are fed to the calves may contain substances that are hazardous to human health. Avoid direct contact and always wear protective gloves and goggles when handling these substances.

- **Chemical burns.** The cleaning agent used to clean the automatic feeder contains caustic substances. These can cause severe injuries to the hands or eyes. Avoid direct contact and always wear chemical-proof protective gloves and goggles when handling the cleaning agent.
- **Excessive strain.** The automatic feeder weighs 80 kg. Never attempt to carry it by yourself as this can cause excessive physical strain.

2.3.2 Material damage caused by the automatic feeder

The automatic feeder can cause the following types of material damage:

- **Infection.** Improper cleaning or incorrect operation can result in calves becoming infected by pathogens from the automatic feeder. This can lead to medical costs or to the death of the calves.
- **Corrosion.** Improper cleaning or maintenance can result in the automatic feeder ceasing to function correctly.
- **Loss of stability.** The automatic feeder must be set up on a level surface. Otherwise, the automatic feeder can tip over and suffer damage.

2.4 What hazard warnings are provided?

Hazards are indicated directly on the automatic feeder by safety labels (warning signs, instruction and prohibition notices), and in the operating manual by specially marked hazard descriptions.

The warnings for hazards that can cause death or injury to people are emphasized more than those for material damage, for example through the colors, hazard words or symbols used.

Safety labels are an important element of the overall automatic feeder safety concept. They provide warnings about hazards and explain how to avoid them.

Make sure that all the specified safety labels are fitted to your automatic feeder and that they are in a legible condition. If the safety labels are difficult to read, replace them immediately. New safety labels are available from Förster-Technik GmbH.



2.4.1 Components of a hazard description

A hazard description is always made up of the following elements:

- The hazard word (Danger, Warning, Caution, Attention).
- The nature of the hazard (what could happen?).
- The location of the hazard (where can it occur?).
- The actions to take to prevent the hazard (what do I need to do?).

2.4.2 Hazards causing death or injury

Depending on their severity and the probability of them occurring, hazards that can cause death or injury to people are indicated by a hazard symbol  (warning triangle with exclamation mark) and the following hazard words:

- The word **DANGER** indicates an imminent hazard that will lead to death or serious injury.
 - Warning signs on automatic feeder: **DANGER** (white text on red background).
 - Operating manual:  **DANGER** (white text on black background).
- The word **WARNING** indicates a potentially hazardous situation that could lead to death or serious injury.
 - Warning signs on automatic feeder: **WARNING** (black text on orange background).
 - Operating manual:  **WARNING** (white text on black background).
- The word **CAUTION** indicates a potentially hazardous situation that could lead to minor injury.
 - Warning signs on automatic feeder: **CAUTION** (black text on yellow background).
 - Operating manual:  **CAUTION** (white text on black background).

2.4.3 Material damage

The word **Attention** indicates possible material damage. The automatic feeder or an object in its vicinity may be damaged, for example a calf.

- Prohibition notice on the automatic feeder: a pictogram crossed out in red in a white circle with a red border indicates something you are not allowed to do.
- Operating manual: **ATTENTION** (white text on black background).

2.5 Safety labels on the automatic feeder

Different safety labels are attached at the hazardous points on the automatic feeder. Warning signs, prohibition and instruction notices.

What are warning signs?

Warning signs consist of:

- A pictogram in a yellow triangle illustrating the potential hazard.

What are prohibition notices?



Prohibition notices show a pictogram of the prohibited action in a red crossed out circle. See adjacent example. They illustrate what you are not allowed to do. In the example, the crossed out hose means that you are not allowed to use high pressure cleaners.

What are instruction notices?



Instruction notices show a pictogram of what you are being instructed to do in a blue circle. They illustrate what you have to do. In the example, the pictogram means that you must always disconnect the plug first.

Other labels



Grounding label You will see this label at the points where you have to ground the equipment.

2.5.1 Warning signs on the machine

Danger of death by electric shock

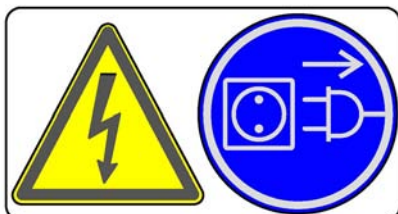

Burns / scalding



Health hazards due to additives



Chemical burns caused by cleaning agents



Automatic startup



Do not spray the equipment down



Grounding label



2.6 Safety equipment on the automatic feeder

The automatic feeder may only be operated if the safety equipment is complete and intact. The automatic feeder has the following safety equipment:

- Safety signs (warning signs, instruction and prohibition signs).
- The heater's safety temperature limiter. This shuts down the heater in the event of overheating (temperature rises above 70°C). The heater may only be reactivated by a service engineer.
- Safety grid for the powder hopper attachment. The safety grid prevents people from being injured by the rotating tools in the hopper, for example when adding milk powder. It must always be installed when the unit is operating.
- The scraper next to milk powder discharge. The powder discharge opening may only be cleaned with the scraper. This prevents finger and hand injuries caused by the powder conveyor starting up automatically.

The safety devices at the machine are an important part of the safety concept and help prevent accidents.

- Do not remove or change the safety devices without observing the corresponding safety instructions.
- Put the machine into service only after all safety devices have been attached and are in protection position.

Safety temperature limiter

The automatic feeder's heater is equipped with a safety temperature limiter which will be triggered in the event of overheating (70°C) and which will then shut down the heater.

The safety temperature limiter is triggered if the water gets too hot or if the heater is running dry. It can be found behind the cover illustrated below.

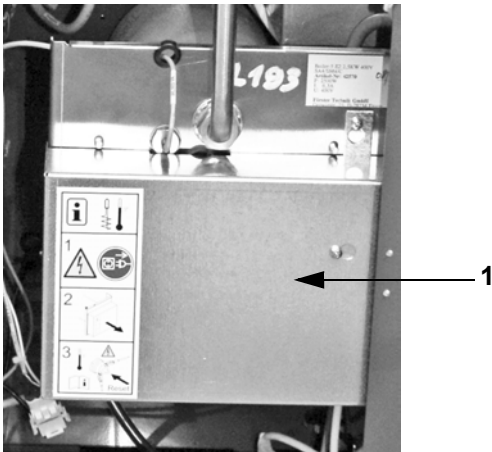

- 1 Cover of the safety temperature limiter

Safety grid for powder hopper attachment

The protective grid for the powder hopper attachment prevents you from being injured by the rotating tools in the powder hopper, for example, when filling in milk powder.



- 1 Protective grid

⚠ WARNING There is a risk of injury due to rotating tools. The safety grid must always be installed when the unit is operating.

Scraper next to milk powder discharge

The powder discharge opening may only be cleaned with the scraper. This prevents finger and hand injuries caused by the mixer starting up automatically.

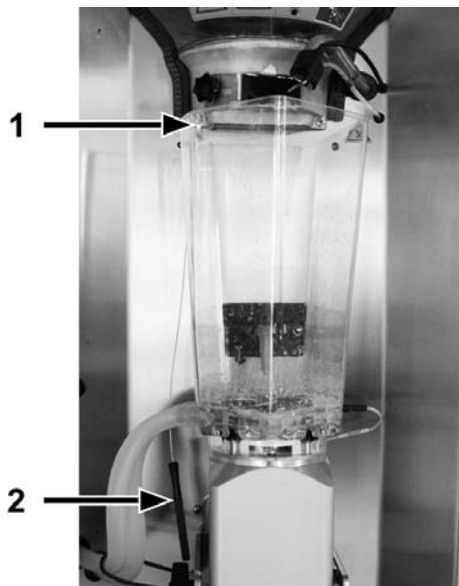

- 1 Mount for scraper
- 2 Scraper

⚠ WARNING There is a risk of injury due to automatic start-up. Do not reach into the hazardous area of the mixer. The mixer can start up automatically at any time, crushing or cutting off your fingers. Always turn off the automatic feeder using the control switch and disconnect the power plug. Only use the scraper supplied to clean the powder discharge opening.

3 Commissioning

Have the end user provide you with the operating manual of the automatic feeder, the separate operating manuals of additional equipment to be connected as well as the safety data sheets for the cleaning agents.

The appendix contains a check list of all instructions that you must observe during the initial startup or restart process. (see **9.1 Checklist for commissioning and recommissioning**, page **125**).

3.1 Setting up the automatic feeder

- > When setting up the automatic feeder, observe the occupational safety measures.

▲ CAUTION Beware of the health hazards caused by lifting heavy loads Never carry the automatic feeder by yourself.

- > Always set up the automatic feeder on an even surface.

Note: Using its adjustable feet, if necessary, you can level the automatic feeder.

- > Set up the automatic feeder in a frost-free location. If this is not possible, inform the end user that he/she must protect the automatic feeder from frost using additional equipment such as the additional frost protection equipment or suction hose heating made by Förster-Technik.
- > If the end user intends to operate the automatic feeder outside of closed spaces, inform the user that he/she must protect the automatic feeder from rain and moisture, for example with a roof.
- > Make sure that there is a drain where the automatic feeder is set up, for the cleaning water.
- > Adjust the length of the drain hose. He must be kept as short as possible.
ATTENTION Make sure that the drain hose is not bent or laid in loops to avoid that it is damaged.
- > Observe the manufacturer's instructions and national regulations for use, storage and installation site of the cleaning agent used (option).
- > Inform the user that the automatic feeder and its cables must be protected from exposure to sunlight.

3.2 Electrical connection provided by the customer

The automatic feeder needs its own power supply.

- The power supply must meet the voltage and frequency specifications. The mains supply must correspond to the supply voltage stated on the left side of the automatic feeder.
- A residual current device (30 mA) in the power supply provided by the customer is compulsory for the operation of the automatic feeder.
- Since it is not technically possible to protect the automatic feeder separately against lightning, you must inform the end user that he/she must provide the appropriate lightning protection (e.g. lightning protection system for the entire building).
- Comply with the local regulations and safety measures.

Grounding

To protect the animals and prevent electrical faults, all metallic objects, such as water pipes, feeding station, stand partition and automatic feeder must be grounded. These locations are indicated by the grounding label (see **2.5 Safety labels on the automatic feeder, page 21**). The connecting screw to ground the automatic feeder is on the right-hand side of the machine housing, directly next to the electrical connection cable. Connect this screw to the local ground via a short, flexible copper cable (minimum cross-section of 4 mm²).

3.3 Water connection

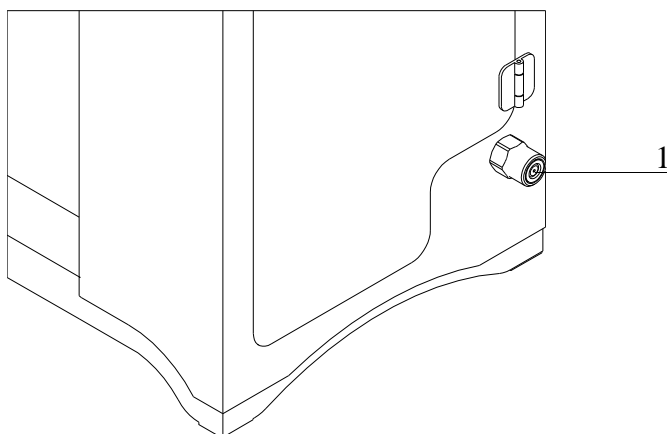

1 Water connection

- > When connecting the automatic feeders, observe the national regulations about protection of drinking water.
- > Inform the end user that the supplied water must be of drinking water quality.
 - ATTENTION** The water should be of drinking water quality. Please bear in mind that high calcium, iron and manganese concentrations cause premature wear. In these cases it makes sense to install appropriate filtration systems.
- > Use a separate water shutoff valve to supply water to the automatic feeder.
- > Make sure the water pressure is constant. The water pressure must be at least 2.5 bar. The maximum pressure must not exceed 6 bar. If the water pressure drops below 2.5 bar for a longer period or permanently, then you will have to install a water tank.
- > Make sure that the water pipe has a sufficiently large cross section. Determine the number of points where water is simultaneously being extracted and adjust the cross section of the water pipe accordingly.

3.4 Installing feeding stations

3.4.1 Installing feeding station

Install the teat at its intended location on the front plate, 10 to 15 cm above the suction hose connection of the mixer and the resulting 50 to 80 cm above the calf's floor level. The corresponding suction bracket with splash guard must point downwards.

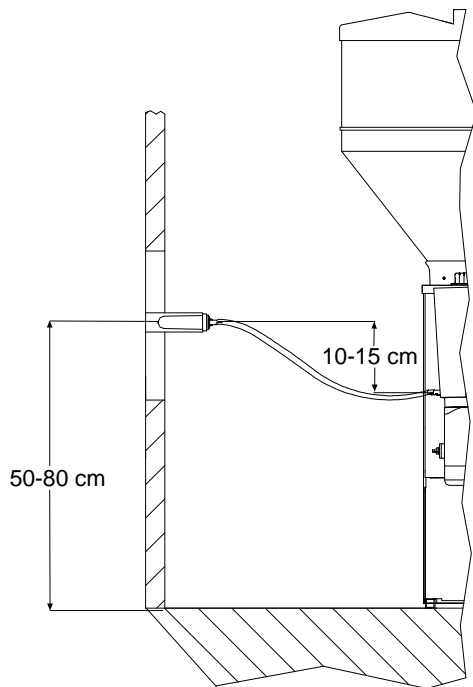

ATTENTION The suction hose may not be longer than two meters. Otherwise, the calves will have problems sucking in the feed. This can lead to malnutrition. Malnutrition can cause impaired growth and development, increased susceptibility to illness or even the death of your calves.

ATTENTION There is a risk of infection due to feed building up in the hose. The hose between the teat and the mixer jar valve (rationed mode) or mixer jar (ad lib mode) must not sag and must be installed at a gradient to the automatic feeder (see the illustration).

3.4.2 Installing stand partition

Install the stand partition in accordance with the manufacturer's instructions.

3.5 Connecting antennas

3.5.1 Installation of antennas

ATTENTION There is a risk of the antenna cables being damaged. Install the antenna cables so that they cannot be damaged by the animals. Observe the separate operating manual for the antennas.

Install the antennas as follows:

- > Keep the distance between the antenna and transmitter as small as possible, no more than 15 - 25 cm. The range of the antenna is, depending on the version, 15 - 25 cm.
- > If necessary, block the area next to the feeding box. This is the only way to prevent a situation in which feed for a calf outside of the feeding box is prepared but the calf does not receive it.

ATTENTION There is a risk of malnutrition if calves do not receive any feed. Malnutrition can cause impaired growth and development, increased susceptibility to illness or even the death of your calves.

- > Check the range of the aerials using the aerial test (see **8.2.3 Identification**, page **111**).
Note: If two calves are identified simultaneously by one aerial, animal identification is interrupted for both calves.
- > The distance between 2 antennas should be approx. 100 cm to avoid any range overlapping.
- > In case double or misidentification occurs, shield the antennas using grounded metal plates.

Note: In order to use winter feed plans, a MultiReader detector with a temperature sensor must be installed at feeding box 1. From January 1, 2013 every MultiReader detector is equipped with this sensor by default. You can check whether your MultiReader detector is equipped with a temperature sensor under **Feeding > Plans > Winter feeding plans** (see the chapter "Feeding > Winter feeding plans" in the automatic feeder's operating instructions).

3.5.2 Squelch values and identification ranges

The approximate range of the antennas is 15 - 25 cm.

The version of the antenna is crucial for the identification range. With Nedap micro-identification, you can set the range via the squelch value.

The squelch values and the identification ranges for the various identification systems are listed in the following table. These squelch values are based on experience and are set at the factory.

If the actual values differ, the settings can be changed in the setup (see **5 Setup**, page **71**).

System	Squelch (default values)	Identification range
Collar (X-responder)	0	15 - 20 cm
Collar (PM-responder)	180	15 - 20 cm
Earmark (also in the collar) (Nedap system)	0	15 - 20 cm
Earmark (also in the collar) (Tiris system)	Inactive	15 - 20 cm

3.5.3 Connecting antenna cables

⚠ DANGER Danger of death by electric shock. The electrical components of the automatic feeder are live. Turning off using the control switch does not disconnect the voltage to the unit. Always turn off the automatic feeder using the control switch and disconnect the power plug before you connect the antenna cables.

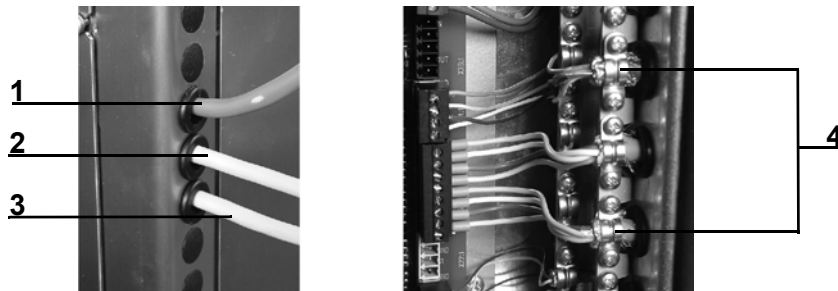

1 Cable of the hand-held terminal	3 Antenna cable of feeding station 2
2 Antenna cable of feeding station 1	4 Cable clamps

Connect the antenna cable as follows:

1. Turn off the automatic feeder using the control switch and disconnect the power plug.
2. Connect the antenna cables to the connections provided.

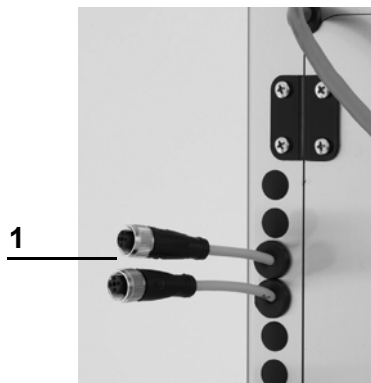

1 Antenna connections

3.5.4 Connecting Ethernet cables

⚠ DANGER Danger of death by electric shock. The electrical components of the automatic feeder are live. Turning off the unit using the control switch does not disconnect the voltage to the unit. Always turn off the automatic feeder using the control switch and disconnect the power plug before you connect the Ethernet cable.

Connect the Ethernet cable as follows:

1. Remove the dummy plug on the feeder housing.

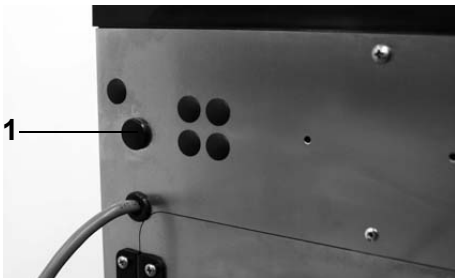

1 Dummy plug

2. Open the left side door of the automatic feeder.
3. Remove the cylinder with the Ethernet connection from the bracket on the feeder housing.



1 Cylinder with Ethernet connection

4. Remove the plugs from the seal and open the screw connection of the cylinder.



1 Seal in cylinder

5. Remove the cable sleeve from the cylinder and attach it at the location of the dummy plug in the feeder housing.
6. Guide the end of the unattached Ethernet cable through the cable sleeve.
7. Screw on the other end of the cylinder and pull out the socket and the Ethernet cable of the automatic feeder.

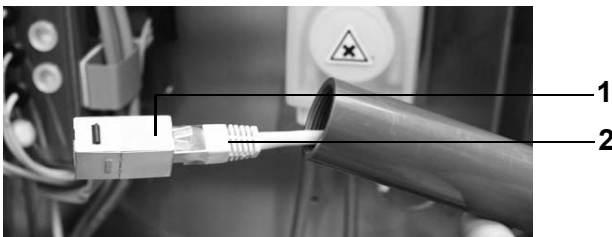

1 Socket

2 Ethernet cable of automatic feeder

8. Place the unattached seal and the screw connection around the unattached Ethernet cable and connect the end to the socket.

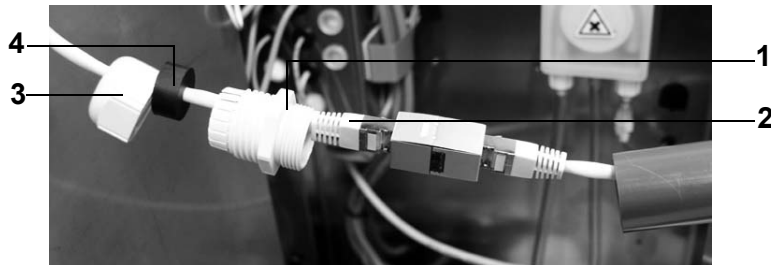

1 Screw connection	3 Screw connection
2 Ethernet cable	4 Seal

9. Insert the cable connector into the cylinder and tighten the cylinder and seals.
10. Push the cylinder into the bracket into the housing of the automatic feeder.

3.6 Installing the safety grid for the powder hopper attachment

Install the safety grid as follows:

1. Turn off the automatic feeder using the control switch and disconnect the power plug.
2. Remove the bag with the small parts and hoses as well as the operating manual from the powder hopper.
3. Insert the safety grid for the powder hopper attachment.
4. Screw in the three self-tapping screws into the holes provided.

3.7 Switching on the condensation prevention heating for powder discharge and frost protection equipment

⚠ DANGER Danger of death by electric shock. The electrical components of the automatic feeder are live. Turning off the unit using the control switch does not disconnect the voltage to the unit. Always turn off the automatic feeder using the control switch and disconnect the power plug before you switch on the vapor barrier.

If the automatic feeder is equipped with a vapor barrier for the powder discharge and/or frost protection equipment, you must check whether the respective switches on the processor board

are switched on. If not, you must turn on the switches. You can set the vapor barrier switch to 0 during summer.

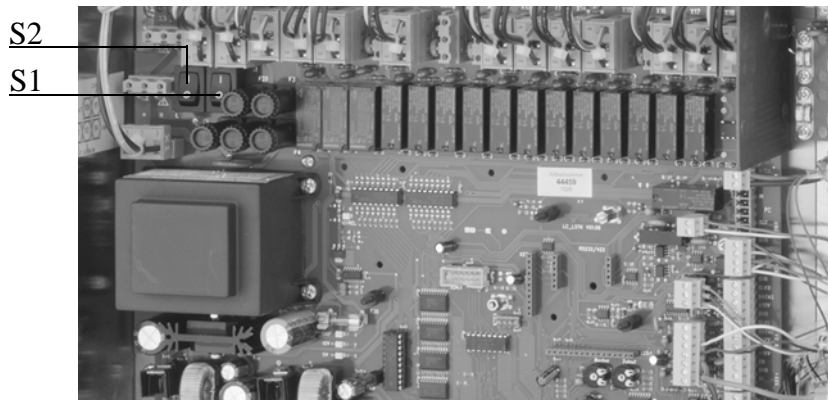

S2 = switch for frost protection equipment
--

S1 = switch for vapor barrier for powder discharge
--

3.8 Filling the powder container

1. When filling the milk powder hopper observe all labor safety precautions.

⚠ CAUTION Beware of the health hazards caused by lifting heavy loads. Make sure that you do not overload when filling the milk powder hopper. Corresponding auxiliaries may be necessary.

2. Fill the powder container with milk powder (MP).

⚠ ATTENTION There is a risk of malnutrition if calves powder container are empty. Malnutrition can cause impaired growth and development, increased susceptibility to illness or even death of the calves. Inform the user that he/she must immediately refill an empty powder container or milk tank or he/she must provide the calves with feed using an alternative method.

3.9 Installing the external detergent supply line (option)

Depending on the model, the automatic feeder is equipped with an external detergent supply line.

Observe the manufacturer's instructions and national regulations for use, storage and installation site of the cleaning agent used.

⚠ WARNING **Chemical burns** due to the cleaning agents used. The cleaning agent can cause chemical burns to your eyes or hands. Always wear safety glasses and safety gloves when

working with cleaning agents. Observe all safety instructions listed in the safety data sheet of the cleaning agent and wear the safety equipment required there.

ATTENTION The detergent container must be placed so that it cannot tip over and calves, unauthorized persons and children do not have access to it.

The detergent dispenser can be freely selected. Proceed with the installation as follows:

1. Drill a hole for the detergent lance into the lid of your detergent container.
2. Fix the detergent lance through the lid in your detergent container.

Note: Small vent holes in the lid prevent the contraction of the detergent container. Please refer to the manufacturer's instructions and national regulations.

3. Place the detergent container in the place provided for it.

3.10 Switching on the automatic feeder

Connect the power plug and turn on the automatic feeder again using the control switch. Use the hand terminal to control the automatic feeder.

Note: After the hand terminal has been switched on, the version of the hand terminal's program first briefly appears in the display, before the automatic feeder carries out a test routine. Do not press any buttons on the control panel during these initial routines.

3.11 Filling the boiler





1. In the display, you can see the fault message **Boiler not filled**. Press .
2. Confirm **Fill boiler?** by choosing .
3. The boiler will be filled with water.

3.12 Reconfiguring everything

During the initial startup and restart process for the automatic feeder, the program (software) must be completely reconfigured (reset). This will remove superfluous data as well as outdated or incorrect settings from the memory.

Note: Choosing **New installation** deletes the **animal data** (group membership, barn transfer date, feeding days, consumption sums), the **transmitter numbers** are set to zero and the **device data** and the **feeding plans** are overwritten with default values.

Reconfigure all menus as follows:

1. Choose  > **Device data** to go to the **New installation** submenu.
2. Confirm **Everything** by choosing .
3. Confirm **Reinstall everything?** by choosing .
4. Confirm the security prompt **Do you really want to restore the data to factory settings?** by choosing .

The message **New installation completed!** will appear.

5. Confirm **New installation completed!** by choosing .



All data has been reset to factory settings.

Note: The settings in the feeder setup are not changed by **new installation** .

3.13 Setting offline mode

You define a period in the **Autostart** menu option on the offline screen. The default setting is 20 minutes.

You set the autostart as follows:

1. Go to offline mode by pressing .
2. The following appears in the display:
 - Start automatic?
 - Time
 - Date
 - Autostart
3. In the Autostart menu, press .
4. Choose the **maximum duration** of offline mode during an extended period of inactivity of the automatic feeder.

Note: The automatic feeder will automatically return to automatic mode.

3.14 Setting the portion

ATTENTION Feed temperatures that are too low can cause digestion problems in calves and feed temperatures that are too high can cause gastritis in the abomasum. The temperature of

the feed in the mixer jar must correspond to the mixing temperature specified by the MP manufacturer. Keep to the feed temperatures recommended in this operating manual.

In the device data menu (see **4.5 Device data**, page **56**) you can make the following settings for the feed portion:

- Adjust the set temperature of the feed in the mixer jar (see **4.5.3.1 Setting the set and minimum temperature**, page **59** and following pages).
- Set the minimum temperature of the water in the boiler (see **4.5.3.1 Setting the set and minimum temperature**, page **59** and following pages).
- Set a pause between the dispensing of two portions (see **4.5.3.2 Dispensing pause**, page **59**).

3.15 Setting operating modes

You set the **operating modes** for the automatic feeder in the **Device data** menu (see **4.5.1 Operating modes**, page **57** and onwards).

The automatic feeder operates in rationed mode by default, but can also be switched to ad lib mode.

3.16 Checking and setting the time/date

During the initial startup process, you must check and, if necessary, correct the time and the date. Time and date are shown in automatic mode (see **4.5.2 Checking and setting the time/date**, page **58**).



Note: In order to force an immediate daily offset after changing the date, you have to switch the feeder off and then on again.

3.17 Drain time station parameters

In the **Feed** menu, you can define the drain time for each feeding box. The drain time starts when the rod electrode becomes free for the last portion and ends when the feeding box valve concerned closes (see **4.5.4 Drain time station parameters**, page **61**).

If calves do not finish drinking the contents of the mixer jar within the standard setting for drain time, the drain time can be extended.



3.18 Function keys

The hand terminal has two freely programmable function keys  and . You define which functionality or which menu will be opened when the respective function key is pressed (see **4.5.5 Function keys**, page **61**).

3.19 Animal list

The animal list is assigned to the  key by default (see **4.5.6 Animal list**, page **62**).

Here is how you define which parameters are displayed in the two columns of the animal list:

1. Choose  > **Device data** to go to the **Animal list** submenu.
2. In **Column 1** or **Column 2**, select the parameter by choosing  or . You can choose between **Feed consumption in %**, **Feed consumption in liters**, **drinking speed in %**, **Animal visits** and **Break offs**.

3.20 Checking the components

In the **Diagnosis** menu you can check alle the components that ahve to be calibrated. This check is necessary to carry out calibration.

3.21 Calibrating feed components

You must calibrate the feed components first so that they are mixed in the right proportion (see **8.5 Diagnosis** on page **119**).

3.21.1 Manually calibrating liquid and powder components

If your automatic feeder does not have an **automatic calibration scale**, you must provide the following items for the calibration:

- 1 graduated cylinder with gradations in ml (approximately 1 liter capacity).
- 1 scale (weighing accuracy of 1 g).
- 1 container to collect milk substitute.

3.21.1.1 Calibrating without a calibration scale

You determine the actual value using a scale and a graduated cylinder and the program will prompt you to enter this value using the number keys.

Proceed as follows to calibrate powder components without a calibration scale:

1. Choose  > **Calibration** to go to the **Components** submenu.
2. In the **MP** menu, you calibrate the milk substitute.
 - Confirm **MP** by choosing .
 - **Set quantity** shows the amount of milk substitute (MP) to be dispensed by the automatic feeder.
 - **Runtime** shows the time in which the automatic feeder should dispense the MP.
 - **Date** shows when MP was last calibrated.
 - Tilt the empty mixer forward.
 - Hold the container for the MP under the powder discharge.
 - Confirm **Start?** by choosing .
 - Confirm **Exit automatic mode?** by choosing . This message will only be displayed if your automatic feeder is still in automatic mode.

Powder will be dispensed.
 - Place the container with the collected MP on the scale.
 - In the **Actual** menu, enter the weight displayed on the scale.
 - Confirm **Confirm value....** by choosing .
 - **Date** now shows the current date.
 - Repeat the calibration to check your results.
 - Calibrate other **powder components** using the same method.

Proceed as follows to calibrate liquid components without a calibration scale:

1. Choose  > **Calibration** to go to the **Components** submenu.
2. In the **Water** menu, you calibrate water.
 - Confirm **Water** by choosing .
 - **Set quantity** shows the amount of water that the automatic feeder should dispense.

- **Runtime** shows the time in which the automatic feeder should dispense the water.
- **Date** shows when the water was last calibrated.
- Confirm **Start?** by choosing .
- Confirm **Exit automatic mode?** by choosing . This message will only be displayed if your automatic feeder is still in automatic mode.

Water will be dispensed into the mixer.

- Tilt the mixer so that the water flows into the graduated cylinder. Measure the collected water in milliliters.
- In the **Actual** menu, enter this measured quantity using the number keys.
- Confirm **Confirm value....** by choosing .
- **Date** now shows the current date.
- Repeat the calibration to check your results.
- Calibrate other **liquid components** using the same method.

3.21.1.2 Calibrating using the calibration scale

The automatic feeder determines the actual value using the built-in automatic calibration scale (additional equipment). To calibrate the components with the scale, the automatic feeder must first be calibrated itself in the setup menu (see **5.7 Calibration scale**, page **78**).

Proceed as follows to calibrate liquid components using the calibration scale:

1. Choose  > **Calibration** to go to the **Components** submenu
2. In the **Water** menu, you calibrate water.
 - **Set quantity** shows the amount of water that the automatic feeder should dispense.
 - **Runtime** shows the time in which the automatic feeder should dispense water.
 - **Date** shows when the water was last calibrated.
 - Confirm **Start?** by choosing . The calibration procedure will start. The set value of 250 ml will be shown first in the display.

- Confirm **Exit automatic mode?** by choosing . This message will only be displayed if your automatic feeder is still in automatic mode.

The device now performs two check weighings without the user having to do anything and shows the result.
 - Then the average value of these two control weighings is shown flashing in the **displayed** line. Confirm the **Confirm value....** prompt by choosing . You then return to the calibration menu.
 - **Date** now shows the current date.
 - Repeat the calibration to check your results.
3. Calibrate other **liquid components** using the same method.

Proceed as follows to calibrate powder components using the calibration scale:

1. Choose  > **Calibration** to go to the **Components** submenu.
2. In **MP**, you calibrate the milk substitute.
 - Confirm **MP** by choosing .
 - **Set quantity** shows the amount of MP that the automatic feeder should dispense.
 - **Runtime** shows the time in which the automatic feeder should dispense the MP.
 - **Date** shows when MP was last calibrated.
 - Confirm **Start?** by choosing .
 - Confirm **Exit automatic mode?** by choosing . This message will only be displayed if your automatic feeder is still in automatic mode.
 - Place the calibration box into the mixer jar and confirm the prompt **Calibration box used?** by choosing .

The device now performs two check weighings without the user having to do anything and shows the result.

 - Then the average value of these two control weighings is shown flashing in the **displayed** line. Confirm the **Confirm value....** prompt by choosing . You then return to the calibration menu.

- **Date** now shows the current date.
- Remove the calibration beaker from the mixer jar.
- Repeat the calibration to check your results.

3. Calibrate other **powder components** using the same method.

Proceed as follows to calibrate the detergent using the calibration scale:

1. Choose  > **Calibration** to go to the **Components** submenu.
2. In the **Detergent** menu, you calibrate the cleaning agent.
 - Confirm **Detergent** by choosing .
 - **Set quantity** shows the amount of cleaning agent that the automatic feeder should dispense.
 - **Runtime** shows the time in which the automatic feeder should dispense the cleaning agent.
 - **Date** shows when the cleaning agent was last calibrated.
 - Confirm **Start?** by choosing .
 - Confirm **Exit automatic mode?** by choosing . This message will only be displayed if your automatic feeder is still in automatic mode.
 - Place the calibration box into the mixer jar and confirm the prompt **Calibration box used?** by choosing .

Detergent will be dispensed into the calibration beaker.

 - The device now performs two check weighings without the user having to do anything and shows the result.
 - Then the average value of these two control weighings is shown flashing in the **displayed** line. Confirm the **Confirm value....** prompt by choosing . You then return to the calibration menu.
 - **Date** now shows the current date.
 - Remove the calibration beaker from the mixer jar.
 - Repeat the calibration to check your results.

3.21.2 Automatic calibration

If the automatic feeder has a calibration scale, it should be used to perform a daily automatic calibration during normal operation of the feed components to be dispensed. If the calibration value determined during the automatic calibration deviates from the entered tolerance value, then the calibration value already determined remains valid. A **Calibrating warning** will then be issued.

You set the start of calibration as follows:

1. Choose  > **Calibration** > **Settings** to go to the **MP or water** submenu.
2. In the **Calibr./day** menu, enter the required number of calibrations per day (MP) or, in the **Autocalib.** menu, select **yes** (water).
Note: If the value **0** is set in the **Calibr./day** menu, then the automatic calibration is deactivated.
3. Under **Calibration times**, define the times at which the calibration procedures are to take place.
Note: Calibration of MP will take place **from** the set time. First however, a calf must feed starting at the set calibration time so that calibration can be started.
4. Enter the required percentage in the **Tolerance** menu option.

Calibration procedures/day	Water	Milk powder
Default value:	Yes	1
Amount changeable:	no	yes
Range of values:	yes/no	0 to 4

Note: The automatic feeder has a volume control valve that compensates for water pressure fluctuations.

3.22 Checking or setting cleaning settings

Check the settings for temperature of the cleaning water, detergent amount and teat cleaning and, if necessary, set them. (see the **Cleaning > Settings** chapter in the operator's manual for the automatic feeder).

3.23 Cleaning the automatic feeder

For hygienic reasons, you must completely remove any coolant and lubricant remnants from the system before commissioning. To do this, execute the cleaning cycle. (see the **Cleaning > Cleaning cycle** chapter in the operating manual for the automatic feeder).

⚠ WARNING Beware of chemical burns from cleaning agents. The cleaning agent can cause chemical burns to your eyes or hands. Always wear goggles and chemical-proof protective gloves when using cleaning agents. Follow all the safety instructions listed in the safety data sheet for the cleaning agent and wear the specified safety equipment.

3.24 Reading in and creating transmitters

During the initial startup process for the automatic feeder, the transmitters have to be read and created once in the system. When you do this, each transmitter number is assigned one animal number of no more than six digits. These animal numbers are then available and can be used to register the animals (see **6 Transmitter and animal management**, page **83** and the following pages).

3.25 Registering animals

Animals will only be fed at the feeder if they are also registered for that feeder (see **6.2 Registering animals**, page **88** and the following pages).

3.26 Entering correction days

During commissioning, the total feeding duration of an animal can be reduced by “shifting” the animal to the desired plan day. (see the **Operation > Feeding** chapter in the operating manual for the automatic feeder).

4 Programming and control

You control the automatic feeder using the hand terminal. The hand terminal is directly connected to the automatic feeder by a cable. You switch it on and off together with the automatic feeder. It remains in operation as long as the automatic feeder is switched on.

Note: After the hand terminal has been switched on, the version of the hand terminal's program first briefly appears in the display, before the automatic feeder carries out a test routine. Do not press any buttons on the control panel during these initial routines.

- You monitor and control the automatic feeder (the **feeding pump**, for example) directly via the keys of the hand terminal.
- You monitor and change the settings of the automatic feeder and the values of calves via menus. The menus and sub-menus are arranged so that you can find the necessary settings quickly and easily. With a click of a button, you can access the most important menus, such as **Animal control**, **Main menu** and **Manual functions** as well as the **Animal list**.

4.1 Hand terminal

4.1.1 The 15-key hand terminal

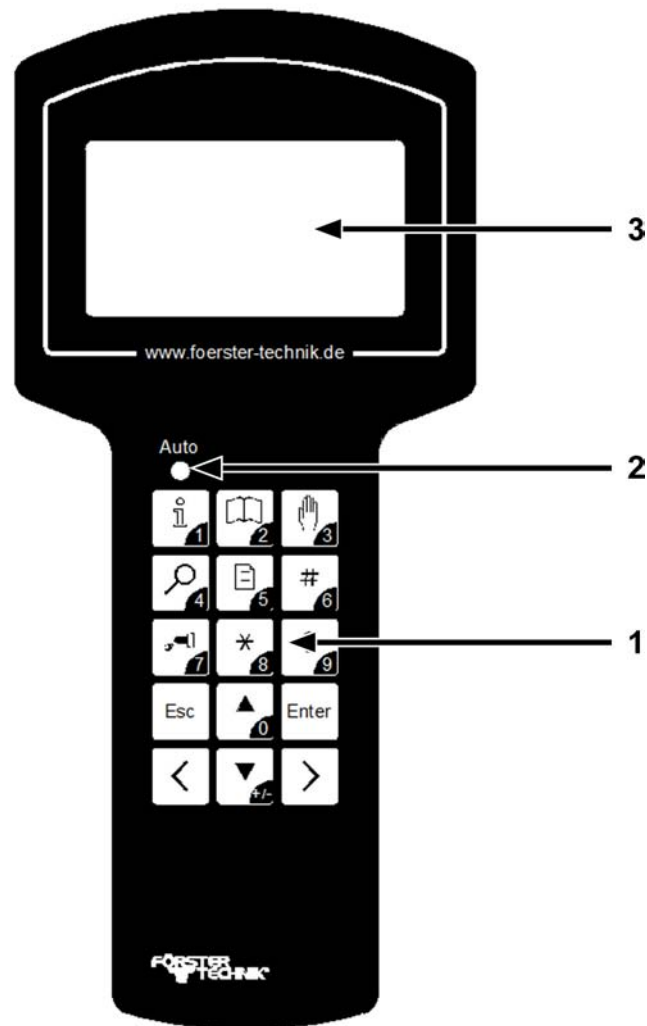

- 1 Keypad
- 2 Auto LED
- 3 Display

Keypad



With this key, you open the **Animal control** menu or enter the number 1.



With this key, you open the **Main menu** or enter the number 2.



With this key, you open the **manual functions** menu and enter the number 3.



With this key, you open the **Search functions** or enter the number 4.



With this key, you open the **animal list** and enter the number 5.

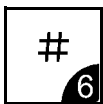

This key is a freely selectable **function key**. With this key, you can also enter the number 6.



With this key, you activate the **feeding pump** or enter the number 7.



This key is assigned 2 functions:

- You press this key to select a calf in submenus in which an animal number is displayed. An asterisk (*) is displayed in front of the animal number of a selected calf. You deselect the calf by pressing this key again.
- In the overview menu in automatic mode, you use this key to toggle between the four-line (large font) and the eight-line (small font) display.

With this key, you can also enter the number 8.



This key is assigned 2 functions depending on the menu you are currently in:

- You use this key to delete warnings and alarms.
- In the overview menu of automatic mode, you use this key to bring warnings to the foreground.

With this key, you can enter the number 9.

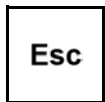

You use this key to go backward within the menu structure. You return to the starting menu by pressing this key multiple times.

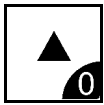

You use this key to move the cursor upward and choose items from a list, for example [yes] or [no]. With this key, you can enter the number 0.



With this key you move the cursor downward and select items from a list. You use this key to change the sign of a number, for example from +1 to -1. This is how you enter negative numbers.



You use this key to confirm your selection and open a menu or an input field. An [input field] is indicated by square brackets.



You use this key to scroll between pages on the screen or list items to the left and jump to the start of a list.



You use this key to scroll between pages on the screen to the right and jump to the end of a list.

4.1.2 Auto LED

The Auto LED (light-emitting diode) of the hand terminal displays important information about the status of the automatic feeder.

- In automatic mode, the LED lights up green.
- In offline mode, the LED is not lit up.
- If a malfunction occurs, the LED flashes.

You can run the automatic feeder in offline mode or in automatic mode.

4.2 Offline mode

In offline mode, you perform actions that you cannot do while the unit is in operation, such as the recalibration of feed components. When the automatic feeder switches from automatic to offline mode, the Auto LED goes out.

You switch to offline mode when you open a menu that requires offline mode, such as the calibration menu.

You switch from automatic mode to offline mode as follows:

1. In the corresponding menu, press .

2. Confirm the message **Exit automatic mode?** by choosing .

The Auto LED on your hand terminal goes out.

3. Perform the desired action.

4.3 Automatic mode

You perform most routine tasks, such as feeding, in automatic mode. In automatic mode, the Auto LED lights up green.

After a prolonged period of inactivity, the automatic feeder automatically returns to automatic mode. This time period is defined during commissioning (see **3.13** Setting offline mode, page **38**). The default setting is 20 minutes.



You switch from offline mode to automatic mode as follows:

1. Press  until the message **Start automatic mode?** appears in your display.
2. Press .

You are now in automatic mode again. The Auto LED lights up green.

4.4 Menu structure

The automatic feeder is controlled using menus, submenus and lists. You control the automatic feeder by switching to lists via menus and submenus. In these lists, you can view and change values. The menu structure makes it easier to find a list quickly.

The menus that you require most frequently, such as **Animal control** , **Main menu**  and **Manual functions**  can be directly accessed with the press of button.

The **animal list** is the list that end users require most often. The animal list can be directly accessed by pressing the  key. You can change this default setting during commissioning to meet the needs of the end user. The user will then access the animal list via the **Animal control** menu.

During commissioning of the automatic feeder, you can assign the  key in accordance with the needs of the end user (see **4.5.5** Function keys, page **61**).

If you do not see all the menus or submenus presented here, this is either because the automatic feeder is not equipped with the component in question, or the component was not activated during setup.

Note: If you know that the automatic feeder has a component that is not being displayed, check the setup (see **5 Setup**, page **71**).

4.4.1 Symbols

Symbols are displayed in front of and in several menus, submenus and lists.

4.4.1.1 Arrows



In automatic mode, arrow heads are shown in front of menus:

- ► A solid arrow head indicates that the menu contains submenus.
- ▷ An empty arrow head means that you can change settings here or start actions.

4.4.1.2 Angle brackets

< > If angle brackets are displayed around a menu or list, it means that you can scroll left to right in order to select menu options or list items. For example, you can select the appropriate calf from a list of animal numbers using the calf's animal number.

4.4.1.3 Square brackets

[] Values or terms are in square brackets. When you press  the value / list item begins to flash in the input field. You can now use the number keys to enter values or use   to select values from a list, such as [yes] or [no].

Note: If you enter a value in an input field and the value is too high or too low, this value will automatically be set to the highest (too high) or lowest (too low) possible value after you press .

4.4.1.4 Rod electrode free/covered

In automatic mode, these symbols are displayed at the top right of the display.



This symbol indicates that the mixer jar is full. The tip of the rod electrode is in the liquid.



This symbol indicates that the mixer jar is empty. The rod electrode is free of the liquid.

4.4.1.5 Animal identification and feed consumption



The antenna symbol after a station number, such as TR 1 for feeding box 1, indicates that a calf has been identified at this station.

✓ A check mark after the antenna symbol means that calf identified at this station may consume feed here.

🔒 A lock symbol after the antenna symbol means that calf identified at this station may not consume feed here. For example, this could be because the concentration of feed in the mixer jar does not match the feed settings for the identified calf.

- A hyphen after the station number indicates that no calf was identified at this station.

4.4.1.6 Plan tendency

The arrow to the right next to the animal number indicates the feeding phase the selected calf is now in.

↗ The feed quantity increases continuously, for example at the beginning of the feeding plan.

→ The feed quantity remains constant, for example in the middle of the feeding plan.

↘ The feed quantity is continuously reduced, for example at the end of the feeding plan.

f The calf is in the 40FIT period.

4.4.1.7 Marking

* Marked calves are indicated by an asterisk to the left of the animal number.

4.4.1.8 Alarms

! An exclamation mark to the left of the animal number indicates that a calf has triggered an alarm.

4.4.1.9 CalfCloud

C This symbol is displayed in the first line of automatic mode if a connection to the CalfCloud exists.

4.4.1.10 Sleep mode

The Förster-Technik logo shows you that no key has been pressed on the hand terminal for an extended period of time. The hand terminal is in sleep mode.

4.4.2 Navigation

You use the hand terminal's keys to navigate through menus, submenus and lists.

By choosing  , you can:

- Move between the different submenus of a menu.
- Navigate between the items of a list, for example between [yes] and [no].

By choosing  , you can:

- Scroll through a list, for example through animal numbers. At the end of the list, the message "end of the list" will appear in the display.
- When you enter numbers, switch between whole numbers, for example from 1 to 2 to 3.
- Jump to the last menu item.

With  you can:

- Confirm an entry.
- Acknowledge a prompt or message shown on the display.
- Confirm a selection.
- Open menus and submenus.
- Open input fields, which are indicated by square brackets.
- Switch from the number before the decimal place to the number after the decimal place in input fields.

With  you can:

- Go back one menu, each time you press the key. You return to the starting menu by pressing this key multiple times.
- Exit the input field or return, without saving, to the number before the decimal place in an input field.

4.4.3 Menus

4.4.3.1 Animal control

You can choose  to open the **Animal control** menu. This menu contains all submenus that the end user requires for daily calf monitoring. The numbers next to the submenus indicate the number of calves recorded in the submenu concerned.

- **Animal list.** You will see a table that shows the calves, sorted by different parameters, such as visits to the feeding box.
- **Entitlement.** A list of calves is displayed, sorted by feed entitlement.
- **Alarm.** You will see a list of the calves that have triggered an alarm.
- **Plan over date.** You will see a list of the calves that have a "plan over" date.
- **Additive** (optional) You will see a list of the calves which receive an additive.
- **40FIT.** You will see a list of the calves which are currently in the 40FIT period.
- **Marked.** You will see a list of calves that have been marked.
- **New.** Here you can view animals that were newly registered in the last 2 days.
- **Double.** Here you assign a new animal number to calves that have been assigned a double animal number.
- **Unknown.** Here you check whether and when the automatic feeder recorded unknown animal numbers. Here you can correctly register calves that have been recorded in this way.
- **All.** You will see a list of all calves.
- **Total consumption.** Several lists are displayed with the consumption amounts of all calves, individual calves and individual groups.
- **Print.** Here you can print out the alarm list and the feed list.

4.4.3.2 Main menu



You can choose  to open the main menu. This menu contains all submenus that the end user requires for daily operation of the automatic feeder.

- **Animal management**
- **Feeding**
- **Calibration**
- **Device data**
- **Cleaning**
- **Diagnosis**

4.4.3.3 Manual functions

You can choose  to open manual functions. Here you can start certain functions of the automatic feeder manually. For example, you can manually empty the mixer or dispense extra portions.

If you press , the automatic feeder switches from automatic to manual mode. The LED extinguishes and the automatic feeder is in offline mode.

You can actively switch the automatic feeder back to automatic mode. Press  until the message **Start automatic mode?** appears in the display. Confirm the message by choosing . The automatic feeder will return to automatic mode. The Auto LED lights up green.

You can control the following functions manually:

- **Extra portion.** Here you can dispense extra portions with or without additives.
- **Mixer: empty?.** The mixer is drained via the mixer drain valve.
- **Boiler water: start?.** Here you add water from the boiler to the mixer.
- **Powder: start?** You start dispensing powder here.
- **Additive 1 start?** (optional). This is where you start dispensing.
- **Mixer: start?.** You start the mixer here.
- **Feeding box.** You open the feeding box valve(s) here.
- **Boiler: fill?.** You automatically fill the boiler with water here.
- **Hoses: open?.** Here you can open several valves simultaneously in order to completely drain all the lines of the automatic feeder of water.

4.5 Device data

The following submenus can be found under **Device data**:

- **Operating modes**
- **Portion**
- **Date/time**
- **Stations**

- **Function keys**
- **Animal list**
- **Data backup**
- **New installation**
- **Cloud**

4.5.1 Operating modes

In the **Operating modes** menu, you set the operating modes of the feeder.

4.5.1.1 Rationed mode / ad lib mode

The automatic feeder operates in rationed mode by default, but can also be switched to ad lib mode.

- In **rationed mode**, the feeder uses animal identification, i.e., the animals are individually fed rationed amounts. Rationed mode is the default setting.
- The feeder does not use animal identification in **ad lib mode**. The **automatic reading in** of transmitter numbers is therefore **not** possible in this operating mode. During feeder operation, a portion is always prepared as soon as the rod electrode in the mixer jar is free (mixer empty). The feeding box valves are constantly open.

⚠ WARNING Beware of the risk of burns on feeding box valves. During prolonged ad lib mode, feeding box valves become hot. You, or the end user, can burn your fingers or hand when touching these valves. For this reason, push the suction hose directly onto the mixer jar spout and disconnect the connector from the feeding box valve.

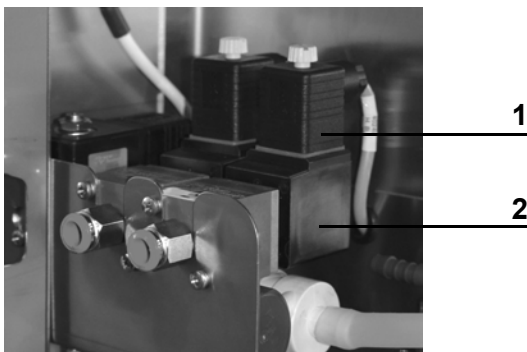

- | | |
|---|------------------------|
| 1 | Female power connector |
| 2 | Box valve |

ATTENTION Cleaning agent that enters the feed can be hazardous to the health of calves. Therefore, always disable all time-controlled cleaning menus and calibrations during ad lib mode.

You set the operating mode as follows:

1. Choose  > **Device data** > **Operating modes** to go to the **Ad lib** submenu.
2. Select the option **yes** in the selection box to activate the ad lib mode. Choose **no** to select rationed mode.
3. In the subsequent lines, if necessary, adjust the values for the **feed concentration** and the **additive dosage**.

Note: These settings are used during the preparation of all feed portions.

4.5.2 Checking and setting the time/date

During commissioning, you have to check and, if necessary, correct the time and the date. Time and date are shown in automatic mode.

Set the time of day, date and date format as follows:

1. Choose  > **Device data** to go to the **Time/date** submenu.
2. In **Time**, you enter the current time of day.
3. In **Date**, you enter the current date.
4. In **Format**, you choose the desired date format.

Note: In order to force an immediate daily offset after changing the date, you have to switch the feeder off and then on again.

4.5.3 Setting the portion

The automatic feeder and preparation of the feed are designed so that even a milk substitute with a higher fat melting point can be easily processed.

ATTENTION Feed temperatures that are too low can cause digestion problems in calves and feed temperatures that are too high can cause gastritis in the abomasum. The temperature of the feed in the mixer jar must correspond to the mixing temperature specified by the MP manufacturer. Keep to the feed temperatures recommended in this operating manual.

In this menu, you make the following settings for the feed portion:

- Set the set temperature of the feed in the mixer jar.
- Set the minimum temperature of the water in the boiler.
- Set a pause between the dispensing of two portions.

4.5.3.1 Setting the set and minimum temperature

Note: The first portion of feed, depending on the ambient temperature, is always mixed somewhat warmer.

Set the set temperature and the minimum temperature as follows:

1. Choose  > **Device data** > **Portion** to go to the **Set temp.** or **Min. temp.** submenu.
2. Enter the desired set temperature in **Set temp.** of the feed in the mixer jar (= mixing temperature).
3. Enter the desired minimum temperature in **Min. temp.** for the water in the boiler.
Enter 0°C in **Min. temp.** in order to disable the minimum temperature parameter.
4. After entering the temperature, check whether the portion is being prepared with the set temperature.

	Set temperature	Minimum temperature
Default value:	42 °C	39 °C
Permitted range of values:	10 °C to 44 °C	0 °C to set temperature minus 0.5 °C

Note: The values that you have entered for set and minimum temperature will be converted to the set and minimum temperature of the boiler water. If the temperature of the boiler water falls below the minimum temperature, the feed preparation will be interrupted until the minimum temperature has been reached again.

4.5.3.2 Dispensing pause

To lengthen the time to prepare the feed, a dispensing pause can be set. As the preparation of a portion starts, the feed station valves will close and stay closed until the dispensing pause is over.

We recommend entering a dispensing pause for:

- milk substitutes with poor solubility,
- very high concentrations (> 200 g/l),

- extreme calf drinking speeds (> 2 l/min).

You set the dispensing pause as follows:

1. Via  > **Device data** > **Portion** go to the **Dispensing pause** submenu.
2. In **Dispensing pause** enter the required value in seconds, from 1-16. The default value is 0.

4.5.3.3 Mixer draining

Leftover feed in the mixer must be evacuated. This is done either via the mixer drain valve or the teat. Alternatively, you can choose not to evacuate residual amounts at all.

ATTENTION Leftover feed in the mixer can lead to an increased risk of infection when outdoor temperatures are high (summer). When outdoor temperatures are low (winter), leftover feed in the mixer becomes so cold that calves will no longer drink it. This can lead to malnutrition. Malnutrition can cause impaired growth and development, increased susceptibility to illness or even death of the calves.

Leftover feed in the mixer jar provides a perfect breeding ground for germs. You specify the amount of time after which this leftover feed is discarded in order to ensure optimal feed hygiene. Mixer draining may also be followed by a drainage procedure (see the **Cleaning** chapter in the operator's manual for the automatic feeder).

4.5.3.3.1 Mixer draining via mixer drain valve

The best and simplest solution is to evacuate the contents of the mixer via the mixer drain valve. You specify whether a mixer drain valve is present during setup (see **5.5.1 Mixer drain**, page **76**).

Note: The mixer drain valve is included by default.

Proceed as follows to specify the amount of time after which a remaining portion in the mixer will be evacuated

1. Choose  > **Device data** > **Portion** to go to the **Draining** submenu.
2. In **Draining**, enter the desired period in minutes.

Default value:	15 min
Permitted range of values:	0 min (= draining deactivated), 5 to 120 min

4.5.3.3.2 Mixer draining via teat

Leftover feed can also be evacuated via the **teat** using the **feeding pump**. Alternatively, you can choose not to evacuate residual amounts at all.

Note: This function only appears if the mixer drain valve is deactivated during setup.

You set mixer drainage via the teat as follows:

1. Choose  > **Device data** > **Portion** to go to the **Drain via teat** submenu.
2. In the **Drain via teat** menu option, specify whether the mixer is to be drained.

4.5.3.4 Mixer OFF delay

You can change the runtime of the mixer in the **OFF delay** menu option. Whether and how long the mixer should have an OFF delay depends on the solubility of the milk substitute.

1. Choose  > **Device data** > **Portion** to go to the **Mixer OFF delay** submenu.
2. In **Mixer OFF delay**, enter the desired value.

Default value:	3 sec
Permitted range of values:	0 to 12 sec

4.5.4 Drain time station parameters

In the **Feed** menu, you can define the drain time for each feed station. The drain time starts when the rod electrode becomes free for the last portion and ends when the feed station valve concerned closes.



If calves do not finish drinking the contents the mixer jar within the standard setting for drain time, the drain time can be extended.

You can extend the drain time as follows:









1. Choose  > **Device data** > **Boxes** > **Feed** to go to the **Drink-out time** submenu.
2. In **Drink-out time**, you enter the desired time.

Default value:	16 sec
Permitted range of values:	10 to 60 sec

4.5.5 Function keys

The hand terminal has two freely programmable function keys  and . You define which functionality or which menu will be called up when the respective function key is pressed.

You define the function keys as follows:

1. Choose  > **Device data** to go to the **Animal list** submenu.
2. Choose  or  to go to the desired function, for example **Start mixer**.
3. Choose  to confirm.
4. Choose  or  to select the symbol of the function key to which the assignment is to be made.
 - The list symbol stands for the  key.
Note: This key is assigned the animal list by default.
 - The hash symbol stands for the  key.
 - The hyphen [-] in the selection box is used to remove an assignment.

4.5.6 Animal list



In the animal list menu, you can list the calves in a table sorted by parameters. The table is sorted in ascending order by the first column of the first parameter. Parameters sorted in ascending order. This means that the calf with the greatest need for monitoring is at the very top of the table. The following parameters can be displayed:

- Feed consumption as a percentage
- Feed consumption in liters
- Drinking speed as a percentage
- Animal visits
- Breaks

	column 1	column 2			
1/118	cons.	dr.sp			
▶ 799 ↘A2	29	56	✓	✓+	
744 fA1	29	✓	✓+	✓+	
715 →A1	50	91	91	91	
737 ↗A1	✓	56	✓+	74	
742 fA1	✓	81	✓	✓+	
743 →A1	✓	85	✓+	✓+	
795 →D2	✓	✓	✓	✓	

Note: You can also access the **animal list** directly via the  key.

Here is how you define which parameters are displayed in the two columns of the animal list:

1. Choose  > **Device data** to go to the **Animal list** submenu.
2. In **Column 1** or **Column 2**, choose   to select the parameter to be displayed in the respective column.

You call up an animal list as follows:

1. Choose  to go to the **Animal list** submenu.
2. In the top line, from left to right, you can check the following:

1	2	3	4
1/118	cons.	dr.sp	
▶ 799 ↘A2	29	56	✓ ✓+
...			

- The number of the calf you have selected in the list, counting from the top (1).
 - How many calves are registered (2).
 - The two parameters you have chosen (3 & 4).
3. You can view the following in the subsequent lines, from left to right:

1/118	cons.	dr.sp				
▶ 799 ↘A2	29	56	✓	✓+		
1	2	3	4	5	6	7
2	3	4	5	6	7	8

- The animal number (1).
- The plan tendency (2).
- The group to which the calf concerned has been assigned (3).
- The last feeding box visited (4).
- Parameter 1. The current value (today) is in the column on the left (5). Yesterday's value is in the column on the right (6).

Note: The parameter for feed consumption is simply today's value (consumption until present time) in liters with two decimal places.

- Parameter 2. The current value (today) is in the column on the left (7). Yesterday's value is in the column on the right (8).

Note: If there is a check mark instead of a number, then the value is 100%. A check mark followed by a plus indicates a value greater than 100% (only for drinking speed and visits).

```

1/118 cons. dr.sp
▶ 799 ↘A2 | 29 | 56 | ✓ | ✓+
...

```

Example: The calf shown with the number 799 is in the weaning phase (reduced plan tendency), has been assigned to group A and

has visited feeding box 2. At present, the calf has only called up 29 % of its feed entitlement, yesterday it was only 56 %. The current value for drinking speed is 100% (✓); yesterday it was more than 100% (✓+).

4. By choosing , you can go to the detailed view for the currently marked animal. By choosing you can scroll to the other animals.

```

!< 3469>A1 ↗ 6.0 1
▶ cons. %:      25  100
break off:     1    0
speed. %:     85  100
visit:        3    6
C 1 %:       99  100
weight kg:   117  116
w. gain:    600  400
feed. day:   77

```

Note: In each line, by pressing , detailed information can be called up.

4.5.7 Backing up and restoring data

Every day at midnight, a backup of **animal data** and **device data** is performed automatically so that a current backup of data is available in case of data loss.

ATTENTION Data can be lost when the program version of the automatic feeder is updated. You must also save the data of the automatic feeder manually, for example to an SD card. Otherwise, calves may suffer from malnutrition if incorrect feed portions are dispensed. Malnutrition can cause impaired growth and development, increased susceptibility to illness or even the death of your calves.

4.5.7.1 Internal data backup (automatic feeder)

4.5.7.1.1 Saving data

You save data as follows:

1. Choose  > **Device data** > **Data backup** to go to the **Internal (feeder)** submenu.
2. Confirm **Save?** by choosing .

A progress bar informs you about the current status of the data backup being carried out.

4.5.7.1.2 Restoring data

You restore data as follows:

1. Choose  > **Device data** > **Data backup** to go to the **Internal (feeder)** submenu.
2. Confirm **restore?** .
3. Confirm the security prompt **restore last backup?** by choosing .

A progress bar informs you about the current status of the backup being carried out.

4.5.7.1.3 Checking the current data backup

Check the data backup as follows:

1. Choose  > **Device data** > **Data backup** to go to the **Internal (feeder)** submenu.
2. In the **last backup** menu, you can view the time and date of the last backup performed.

4.5.7.2 External data backup using an SD card

During each backup, a folder with the date of the backup is created on the SD card. In the case of a **recovery**, a date stored on the SD card can be entered and selected using the number field. The date of the last backup is always shown on the display.



SD card and hand terminal

Proceed as follows to perform a data backup using an SD card:

1. Open the rubber cover on the right side of your hand terminal.
2. Insert the SD card into its slot.
3. Choose  > **Device data** > **Data backup** to go to the **SD card** menu.
4. Confirm **save?** with .

A progress bar informs you about the current status of the data backup being carried out.

This is how to perform a backup:

1. Choose  > **Device data** > **Data backup** to go to the **SD card** menu.
2. Confirm **restore?** by choosing in order to perform a backup.
 - 2.1 If required, in the **Date** menu, enter a date, from which you would like to restore the data, and confirm this with .
3. In the **Date** menu, you can see when the last data backup was performed.
4. Remove the SD card.
5. Close the rubber cover.

4.5.7.3 Cloud

In this menu, you can back up data to the cloud.

Perform a backup as follows:

1. Choose  > **Device data** > **Data backup** to go to the **Cloud** menu.

2. Confirm **save?** by choosing .

A progress bar informs you about the current status of the data backup being carried out.

This is how to perform a backup:

1. Choose  > **Device data** > **Data backup** to go to the **Cloud** menu.
2. Confirm **restore?** by choosing in order to perform a backup.
 - 2.1 If required, in the **Date** menu, enter a date, from which you would like to restore the data, and confirm this with .
3. In the **Date** menu, you can see when the last data backup was performed.

4.5.8 New installation

The program (software) must be completely reinstalled (reset) when commissioning or recommissioning the automatic feeder. This will remove superfluous data as well as outdated or incorrect settings from the memory.

Note: **New installation** will result in the deletion of the **animal data**. The **transmitter numbers** will be set to zero and the **Device data** will be overwritten with default values.

Animal data is, for example, group membership, barn transfer date, feeding days, consumption totals.

Device data includes portion settings, for example.

4.5.8.1 Only reinstall device data, plans, animal data or transmitter numbers

Proceed as follows to reinstall device data, plans, animal data and transmitter numbers:

1. Choose  > **Device data** to go to the **New installation** submenu.
2. Confirm **Device data** by choosing .
3. Confirm **Reinstall device data?** by choosing .
4. Confirm the security prompt **Do you really want to restore the data to factory settings?** by choosing .

The message **New installation completed!** will appear.

5. Confirm **New installation completed!** by choosing .

You are back in the **New installation** menu.

6. Perform steps 2 to 5 in the same manner for **plans, animal data** or **transmitters**.

4.5.8.2 Reconfiguring everything

You can also reconfigure all menus instead of individual menus.

Reconfigure all menus as follows:

1. Choose  > **Device data** to go to the **New installation** submenu.
2. Confirm **Everything** by choosing .
3. Confirm **Reinstall everything?** by choosing .
4. Confirm the security prompt **Do you really want to restore the data to factory settings?** by choosing .

The message **New installation completed!** will appear.

5. Confirm **New installation completed!** by choosing .
- All data has been reset to factory settings.

Note: The settings in the feeder setup are not changed by **new installation** .

4.5.9 CalfCloud

In this menu you can find the CalfCloud settings.

1. Move via  > **Device data** to the submenu **Cloud**.
 - In **start?** you can establish the connection between the Cloud and the automatic feeder.
 - Press . The fault menu **last error** will appear. The following error messages can be displayed:
 - **none**. There is no error..
 - **no eth. cable**. No Ethernet cable is connected. If necessary, contact your service technician.
 - **no internet**. There is no Internet connection. If necessary, contact your service technician.
 - **connect.error**. Connection fault to the server. If necessary, contact your service technician.

- In **terminate?** you terminate the connection to the Cloud and thus also the data transmission.
- **Status** shows you the current status of the connection to CalfCloud. **Online**, **offline** or **reconnecting** can be displayed.
- **Auth-Token** shows you the authentication key of the automatic feeder.

Note: With this token you can add the automatic feeder to the Cloud.

4.6 Software update





To update the application program, depending on the device, you have a choice between an SD card or FlashManager.

The options available for your equipment can be seen in the dealer area of Förster-Technik's web site www.foerster-technik.de.

5 Setup

The program menus in the setup menu contain basic settings, e.g. for the equipment of the automatic feeder. Check to ensure that the settings are correct.

You open the setup menu as follows:

1. Press  and keep this key pressed when you switch on the feeder.
After a short time, the setup menu will appear in the display.
2. If you want to change settings, go to the relevant menu option and make the changes.
3. Confirm your changes by choosing .
4. To exit the setup, press  until the message **Exit setup?** appears. Choose  to confirm.

5.1 Overview of the Setup menus

Language		German
Time/date		Time / date
Machine	Type	Powder Milk or combi
	Number	1-99 (= machine number, decimal)
	Address	2-FC (= CAN address, hexadecimal)
	System	Interval (IV)
	Operating mode	SA / SM
	Base size	250 ml
	Heating	mechanical / none
	Boiler valve	Basic
Equipment	Mixer drain	present yes
	⊕ Additive dispenser 1	present yes / no?
	⊕ Detergent pump	present yes / no?
	Detergent sensor	no / rod
	Circulation valve	no
	Circulation pump	present yes / no?
	Mix. sensor T.	present yes / no?
Identification	Type	Multi / Tiris / Ned
	Squelch	0 to 255
ID chip	activated	no
⊕ Calibration scale	activated (yes / no) adjust? Cal. factor Cal. date	
Stations		<internal 1>, <internal 2>
	Feed	<IFS-C 1 .. 8>
	⊕ Concentrate	Allocation: [C-station 1 .. 8]
		Address: 51-60
		Type: Standard
	⊕ Animal scale	Activate
	Adjust	
Terminal	Address	1-FC (= CAN address, hexadecimal)
	Contrast	70%
	Sleep mode	0-999 min.

Communication	Institute	yes / no
	Printer	no / serial / CAN
	Gateway	MAC: IP: 0-255 . 0-255 . 0-255 . 0-255 SN: 0-255 . 0-255 . 0-255 . 0-255 IP assignment: manual / autom. Factory settings?
	MultiReader	No Version update Multireader? Temperature Read transponder -type/-country/-no/ Squelch Resets Restarts
	CAN analyzer	CAN devices
		CAN errors
		CAN load
	Network configuration	M: IP: 0-255 . 0-255 . 0-255 . 0-255 SN: 0-255 . 0-255 . 0-255 . 0-255 GW: 0-255 . 0-255 . 0-255 . 0-255 IP assignment: DHCP / static accept?
	Cloud	
	Restart	Restart?
SD card	Feeding plans	Feeding plans read in / active / changed
	Licenses	Request license/ Read data/ Active licenses
Service	Initial operation: Date last: Date Type: RS1/RS2/RS3 next: Date Type: RS1/RS2/RS3 Service done?	

5.2 Language

You select the language for the user interface of the feeder as follows:

1. In the setup menu, choose the **Language** option.
2. Select the desired language for the user interface.
3. Confirm your entry by choosing .

5.3 Time/date

You set the time / date as follows:

1. In the setup menu, choose the **Time / date** option.

2. Enter the current time of day and the current date.
3. Confirm your entries by choosing .

5.4 Machine

5.4.1 Feeder type

There are three different automatic feeder types:

- **Powder:** feeds MP water mixtures.
- **Combi:** feeds fresh milk as well as MP water mixtures.
- **Milk:** feeds fresh milk only.

You select the feeder type as follows:

1. Leave the factory default value as it is.

5.4.2 Feeder number

For the KalbManagerWIN program (optional additional equipment) to access the automatic feeder's software, the automatic feeder needs a number. Number 1 is set by default.

Note: When connecting more than one automatic feeder, be sure that each number is only assigned once.

You select the feeder number as follows:

1. In the setup menu, choose the **Machine** option.
2. In **Number**, you select a number.
3. Confirm your entry by choosing .

5.4.3 Feeder address

For clear identification, every participant of the CAN bus system needs an address.

Address ranges for members of CAN networks	
1-10	=> hand terminal
11-20	=> automatic feeder
21-30	=> Forefoot weighing machine
41-50	=> IFS feed single
51-60	=> IFS-C
61-70	=> IFS feed quadruple
71-79	=> CalfRail

You select the feeder address as follows:

1. In the setup menu, choose the **Machine** option.
2. In **Address**, you select an address.
3. Confirm your entry by choosing .

Note: If you select an address that has already been assigned, the message **Address already assigned!** will appear in the display.

5.4.4 Feeder operating mode

The automatic feeder can be operated in **Stand Alone (SA)** mode or **System machine (SM)** mode. Please leave the factory set value **SA** (= Stand Alone) as it is.

5.4.5 Base size

The set value determines:

- The set quantity for calibrating **Boiler water**.
- The standard portion size.

You define the size as follows:

1. In the setup menu, choose the **Machine** option.
2. Under **Base size** enter 250.
3. Confirm your entry by choosing .

5.4.6 Heating

Here you specify whether the feeder has a heater and, if so, what type of **heating relay** it has.

You set the heating type as follows:

1. In the setup menu, choose the **Machine** option.
2. In **Heating**, select **mechanical**.
3. Confirm your entry by choosing .

5.4.7 Boiler valve

Please do not change the factory settings.

5.5 Equipment

Here you specify whether the automatic feeder is equipped with certain components or options.

5.5.1 Mixer drain

The contents of the mixer are drained fully automatically via the mixer drain valve. The mixer drain valve is included by default.

You set the mixer drain valve as follows:

1. In the setup menu, open the **Equipment** option.
2. In **Mixer drain**, choose **yes** if a mixer drain valve is present, otherwise choose **no**.
3. Confirm your entry by choosing .

5.5.2 Additive dispenser

You activate the additive dispenser as follows:

1. In the setup menu, open the **Equipment** option.
2. In **Add. disp. 1** select **yes** if there is an additive dispenser, otherwise choose **no**.
3. Confirm your entry by choosing .

5.5.3 Detergent pump

Detergent is fully automatically dispensed via the detergent pump during a cleaning cycle.

You set the detergent pump as follows:

1. In the setup menu, open the **Equipment** option.
2. In the **Detergent pump** menu, choose **yes** if there is a detergent pump, otherwise choose **no**.
3. Confirm your entry by choosing .

5.5.4 Circulation valve

Please do not change the factory setting [**no**].

1. In the setup menu, open the **Equipment** option.
2. In **Circ. valve**, choose **no/HE**.
3. Confirm your entry by choosing .

5.5.5 Mixer temperature sensor

The temperature sensor in the mixer continually records the temperature of the feed in the mixer jar. If the temperature deviates from the set value, the boiler heater will be adjusted to compensate. The feed always has the desired temperature, regardless of the season.

You set the mixer temperature sensor as follows:

1. In the setup menu, open the **Equipment** option.
2. In **Mix. sensor T**, choose **yes** if there is a temperature sensor, otherwise choose **no**.
3. Confirm your entry by choosing .

5.6 Identification

Type and squelch

Here you set the identification system, depending on the identification system of the distribution partner. The input or reading sensitivity of the identification system is set via the squelch value. The larger the entered value, the lower the range of the identification system (see **3.5** Connecting antennas, page **30**).

You set the identification system as follows:

1. In the setup menu, open the **Identification** option.
2. In **Type**, select the identification system.

3. In **Squelch**, select the squelch value.
4. Confirm your entry by choosing .

5.7 Calibration scale

You activate the calibration scale as follows:

1. In the setup menu, open the **Calibration scale** option.
2. In **activated** choose **yes** if a calibration scale has been installed.
3. Confirm your entry by choosing .
4. Press **adjust?** to adjust the calibration scale.
5. The adjustment process begins with the taring of the calibration scale. You will be informed of this in the **calibration scale will be tared** message.
6. A menu appears where you need to enter the reference weight in grams that you require for the adjustment. If need be, adapt the respective value in this menu (default value: 500 g).
Note: A 500 g reference weight is included in the delivery.
7. Place the reference weight with the hole on the screw in the feeding box such that it is fixed in place, and then press in order to start the adjustment process.
8. After completing the adjustment process, a corresponding message about the success or lack of success of the adjustment will be issued. At the same time, the currently determined weight value will be shown. After removing the calibration weight, 0 grams should be shown here.
9. Press . **Date** now shows the current date.

5.8 Stations

Activate the feed or concentrate station and define the additional equipment for these stations or any additional equipment in the **Stations** menu. Automatic feeders are normally equipped with one station valve for one feeding box.

5.8.1 Feed

You set the feeding box as follows:

1. In the setup menu, choose the **Stations > Feed > Internal** option.

2. In **Allocation** select the feeding box to be allocated to the internal control system.
3. Confirm your entry by choosing .

5.9 Terminal

5.9.1 Address

The hand terminal is integrated into the CAN bus system of the automatic feeder. That is why it needs its own address. **Address 1** is set by default.

Note: In a CAN bus system, each address may only be assigned once.

You set the address as follows:

1. In the setup menu, choose the **Terminal** option.
2. In **Address**, select **[1]**.
3. Confirm your entry by choosing .

5.9.2 Contrast

You set the contrast as follows:

1. In the setup menu, choose the **Terminal** option.
2. In **Contrast**, enter the desired value. The default value is 60%.
3. Confirm your entry by choosing .

5.9.3 Sleep mode

If no key has been pressed on the hand terminal for a longer period of time, it will switch to sleep mode. If the hand terminal is in sleep mode, the Förster-Technik logo will appear in the display.

You set sleep mode as follows:

1. In the setup menu, choose the **Terminal** option.
2. In **Sleep mode**, enter the required value. The default value is 10 minutes. To deactivate sleep mode, set [0] minutes.
3. Confirm your entry by choosing .

5.10 Communication

5.10.1 Printer

Current animal lists can be generated via the automatic feeder's printer function.

- **Serial:** Select this option if you have connected a commercially available printer via the serial interface to the automatic feeder.
- **CAN:** Select this option if the printing data is to be sent via the CAN bus. In this case, a PC program will play the counterpart.

5.10.2 Gateway

You can configure all relevant parameters of the  Förster gateway here.

- **MAC address:** You can see the MAC address of your gateway here. Your gateway is uniquely identified via its MAC address. This address cannot be changed.
- **IP address:** You can see the IP address of your gateway here and, if need be, change it. You will need this value to register your feeder at the CalfManagerWIN or in connection with the communication module.
- **Subnet mask:** You can see the subnet mask of your gateway here and, if need be, change it.
- **IP assignment:** If the value here is **automatically** set, then your gateway will try to get its IP address from a DHCP server in your network. If you select **manual** here, then you will have to set the IP address of your gateway yourself.
- **DHCP status** (only in connection with the automatic assignment of IP addresses): This line gives you information about the internal status when getting the automatically assigned IP address. There are five statuses that can occur: **OK**, **waiting**, **off**, **on** and **unknown (=n/a)**.
- **Factory settings:** If you call up this item and confirm the security query which then appears, the values of your gateway for the IP address, the subnet mask and the manual or automatic procurement of the IP address will be reset back to the factory settings.

5.10.3 MultiReader

Here, you can call up information about the connected MultiReader calf identification system.

- **Version** shows the current version of the MultiReader identification system.

- In the **Update** menu, if you press , you can update the MultiReader identification system.

Note: To update the MultiReader identification system, you may have to first update the automatic feeder.

5.10.4 CAN analyzer

Here, you can call up information about the CAN bus. This information can be helpful if a fault occurs in the CAN bus system.

5.10.5 Network configuration

You can configure all parameters of the network here.

- **MAC address:** You can see the MAC address of your network here. Your network is uniquely identified via its MAC address. This address cannot be changed.
- **IP address:** You can see the IP address of your network here and, if need be, change it.
- **Subnet mask:** You can see the subnet mask of your network here and, if need be, change it.
- **Gateway:** You can see the MAC address of your gateway here. Your gateway is uniquely identified via its MAC address. This address cannot be changed.
- **IP assignment:** If you select **DHCP** here, the data will be automatically assigned. If you select **static** here, you will have to set the IP address of your network yourself.
- **Accept?:** Press . The data will be saved.

5.10.6 Cloud

Here you can set up the values for CalfCloud and the internet connection from the automatic feeder to the Cloud.

- In **start?** you can establish the connection between the Cloud and the automatic feeder.
 - Press . The fault menu **last error** will appear. The following error messages can be displayed:
 - **none.** There is no error.
 - **no eth. cable.** No Ethernet cable is connected.

- **no internet.** There is no Internet connection.
- **connect.error.** Connection fault to the server.
- In **terminate?** you interrupt the connection to the Cloud and thus also the data transmission.
- **Status** shows you the current status of the connection to CalfCloud. **Online, offline** or **re-connecting** can be displayed.
- **Auth-Token** shows you the authentication key of the automatic feeder.
Note: With this token you can add the automatic feeder to the Cloud.

5.10.7 Restart

You can restart the automatic feeder here.

6 Transmitter and animal management

All menus for management of the list of all transmitters and the calves registered at the feeder can be found via  > **Animal management**.

6.1 Managing transmitters

6.1.1 Basics

6.1.1.1 Identification process at the station

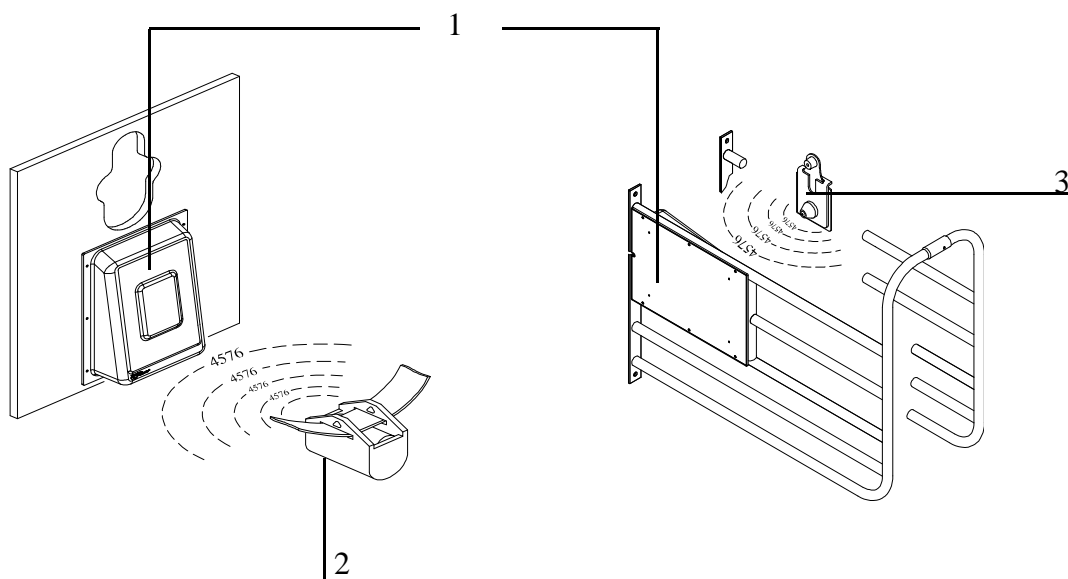

1	Antenna
2	Collar transmitter
3	Earmark transmitter

For identification purposes, each calf wears a collar with a transmitter or an earmark with a transmitter. The transmitter has a multi-digit number, which is also usually stamped into the transmitter housing. This **transmitter number** is sent from the transmitter to the antenna, which is part of the feeding box.

6.1.1.2 Connection of transmitters and animal numbers

The multi-digit transmitter number is not well suited for the rapid location of individual calves. For this reason, a calf is issued an animal number along with the transmitter number. The animal wears this animal number on an easily readable collar, or the animal number is put on the

earmark where it can be easily read. Up to 250 different animal numbers of up to six digits can be assigned to the calves.



6.1.2 Creating transmitter numbers

When the feeder is commissioned, existing transmitters have to be created once in the system. When you do this, each transmitter number is assigned one animal number of no more than six digits. These animal numbers are then available and can be used to register the calves.

6.1.2.1 Reading transmitter numbers

When creating new transmitter numbers, it is a good idea to have these read by the feeder. This saves you from typing in the numbers and eliminates the possibility of typing errors.



To set up the reading of transmitter numbers by the feeder, proceed as follows:

1. Choose  > **Animal management** > **Transmitters** to go to the **New** submenu.
2. Hold a transmitter next to the identification unit of a feeding box.
The number of the transmitter will be read in and displayed in the line after **No. †**. At the same time, the animal number to be newly assigned will be suggested in the **Animal no.** line.
Note: You can affect the suggested animal number by selecting an assignment scheme for the animal numbers in the **No.** line.
3. Check whether the suggested **animal number** is correct and, in the line **accept?**, press .
- Note:** Make sure that the correct feeding box is selected in **Stations**.
4. In order to allocate the newly read transmitter number to the displayed animal number, confirm the security prompt **Create new no. xxx for animal xx?** by choosing .

6.1.2.2 Manually entering transmitter numbers

Instead of reading the transmitters, you can also manually type in the transmitter numbers, if necessary

You manually enter transmitter numbers as follows:

1. Choose  > **Animal management** > **Transmitters** to go to the **New** submenu.
2. Enter the transmitter number in the **No.** menu and confirm it by choosing .

3. In the **Animal No.** menu, check the suggested animal number and confirm it by choosing .
4. Confirm **accept?** by choosing .
5. In order to allocate the newly read transmitter number to the displayed animal number, confirm the security prompt **Create new no. xxx for animal xx?** by choosing .

6.1.3 Assigning animal numbers

If the transmitter numbers are automatically read when new numbers are created, an animal number will be automatically suggested. When doing this, there are two schemes to choose from for the assignment of numbers.

6.1.3.1 Consecutive assignment of animal numbers

There is a counter which counts up for each new transmitter number as it is read. In this way, all of the transmitter numbers that are registered by the identification function are linked to consecutive animal numbers; e.g., from 1 to 50.

You set up consecutive assignment of animal numbers as follows:

1. Choose  > **Animal management > Transmitters** to go to the **New** submenu.
2. Select the **consecutive** option in **No.**
3. If necessary, in **next**, specify the animal number at which you want automatic reading of transmitters to start.

Note: If you use collars, it makes sense to start with 1 and read in the transmitters in order.

6.1.3.2 Assignment of animal numbers based on transmitter numbers

More and more often, calves are already equipped with an electronic earmark transmitter when they are born and keep this earmark their whole lives. The automatic feeder program has been adapted for this type of transmitter so that the registration process of the transmitters and calves can take place completely automatically.

You set up automatic assignment of animal numbers as follows:

1. Choose  > **Animal management > Transmitters** to go to the **New** submenu.
2. Select the **automatic** option in **No.**

3. In the **Range** menu, define the part of the transmitter number that you would like to use as the animal number. The animal number can have a maximum of six digits.

For example: 5-2 means that, counting from the right, the second to the fifth digits of the transmitter number will be used as the animal number. **6-1** means that, counting from the right, the first to the sixth digits of the transmitter number will be used as the animal number.



6.1.4 Editing transmitter or animal numbers

If necessary, (e.g., if a transmitter is lost), a transmitter number can be subsequently changed or deleted.

6.1.4.1 Changing the transmitter number



Manually changing the transmitter number

You manually change a transmitter number as follows:

1. Choose  > **Animal management** > **Transmitters** to go to the **Edit** submenu.
2. Select the transmitter number to be changed.
3. Change the transmitter number in the **No.** menu and confirm by choosing .

Reading the new transmitter number for the change

You read a new transmitter number as follows:

1. Choose  > **Animal management** > **Transmitters** to go to the **Edit** submenu.
2. Select the transmitter number to be changed.
3. Confirm **read?** by choosing .

A new menu is displayed, and the transmitter number flashes in the first line.

4. Hold the transmitter that you want to read next to the identification unit.
The number is automatically accepted in the first line.
5. Confirm **accept?** by choosing .

6.1.5 Changing the animal number

Like the transmitter number, the animal number can also be changed.

1. Choose  > **Animal management** > **Transmitters** to go to the **Edit** submenu.
2. Select the animal number you would like to change.

3. In the **Animal No.** menu, change the animal number that is currently allocated to the transmitter and confirm by choosing .

6.1.5.1 Deleting transmitter numbers

You delete transmitter numbers as follows:

1. Choose  > **Animal management** > **Transmitters** to go to the **Edit** submenu.
2. Select the transmitter number to be deleted and confirm **Delete** by choosing .

Note: You can only delete transmitter numbers of calves that are not registered (= status: available).

6.1.6 Deleting the transmitter number when canceling an animal's registration

Generally, the collars (or earmarks) with the respective transmitters remain at the organization and are reused after the calf is taken out of the pen and its registration is canceled. For this reason, the default setting when canceling the registration of a calf is to not delete its transmitter number. If the calf's transmitter is, however, **not** reused but rather stays with the calf, (life-long earmark), make the following setting in the feeder:

1. Choose  > **Animal management** > **Cancel** to go to the **Settings** submenu.
2. Select the **yes** option in **Delete no.** When a calf's registration is canceled, the transmitter number is also deleted along with the animal number. This prevents an accumulation of unused transmitter numbers, which would use up the available storage space.

6.1.7 Retrieving transmitter statistics

You retrieve a transmitter statistic as follows:

1. Choose  > **Animal management** > **Transmitters** to go to the **Information** submenu.
2. An overview of the transmitters created in the system is displayed. The following is shown in the displayed list:
 - In the **Registered** menu, you check the number of registered transmitters or calves.
 - In the **Available** menu, you check the number of available transmitters.
 - In the **Free** menu, you check how many transmitters you can still create.

6.2 Registering animals

Calves are only fed at the feeder if they are also registered there. You can either manually register each calf or instruct the feeder to automatically register the calves. In the latter case, the calf is registered as soon as it enters the feeding station for the first time. This means that the manual registering of the calves is not needed.

During registration, the calf is allocated to one of four groups, A to D. The calf will then be fed in accordance with the feed and concentration plans of this group.

The group to which you allocate the calves depends solely on the feed quantity, concentration and milk ratio that the end user wants to feed the calves. In this case, it does not matter which station the calves consume their feed in or which bay the calves have been housed in.

6.2.1 Registering animals manually

You register animals manually as follows:

1. Choose  > **Animal management** > **Register** to go to the **Animal** submenu.
2. Select one of the available (not yet registered) animal numbers.
3. In **Group**, select the group to which the calf is to be allocated.
4. If you want to reduce the total feeding duration for the calf, you can set this up under **Correction days** (see **Feeding > Total feeding duration** in the operator's manual).
5. Confirm **Register?** by choosing .
6. Confirm the prompt **Register animal xx in group X?** by choosing .

Note: On its registration day, the animal receives the exact amount of feed, spread over the course of the day, as intended for the first day according to the feeding plan. If you have entered correction days, the animal will receive the feed that is intended for the corresponding day.

Note: For the next manual registration, the values last set will again be shown and can be used or changed for the current animal.

6.2.2 Registering animals automatically

If an animal that is not yet registered enters the feeding station for the first time, it can then be automatically registered. For automatic registration, three different modes can be set which

are described in detail in the following three sub-sections. The following table presents an overview of this.



Overview of the three modes for automatic registration

Automatic registration mode	Transmitter number being identified	
	available	unknown
deactivated	Warning Unknown transmitters	Warning Unknown transmitters
available transmitters	Animal will be registered	Warning Unknown transmitters
all transmitters	Animal will be registered	Transmitter is created, new animal number is assigned, animal is registered

6.2.2.1 Deactivating automatic registration

Automatic registration is deactivated by default. You can restore this setting at any time:

You deactivate automatic registration as follows:

1. Choose  > **Animal management** > **Register** to go to the **Automatic** submenu.
2. Select **Mode no** and confirm by choosing . Automatic registration is then deactivated.

Note: When the registration function is deactivated, the **unknown transmitters warning** will be triggered if an unregistered calf enters a station.

6.2.2.2 Only automatically register available transmitters

Automatic registration shortens the registration process for the calves. When doing this, you can specify that only calves can be registered whose transmitter numbers are already in the system. If an available transmitter number is registered in the identification unit, the corresponding calf will be automatically registered. Calves or transmitter numbers that have not yet been created in the system will trigger the **Unknown transmitter number** warning.

Proceed as follows to set up automatic registration of available transmitters:

1. Choose  > **Animal management** > **Register** to go to the **Automatic** submenu.
2. In **Mode** select the **available** option.
3. In **Group**, choose the group in which you want to automatically register the calves.

Note: The registration of calves that are to be removed should only be canceled after they have left the bay, as they will otherwise automatically be reregistered when they enter the station and will then be returned to the start of the feeding plan.

6.2.2.3 Creating transmitter numbers and automatically registering calves

To shorten the registration process even more, you can specify that calves can also be registered if their transmitter numbers are not known in the system. This eliminates the need for reading or manual entry of transmitter numbers. In this case, if an unknown transmitter number is registered in the identification unit, this transmitter number is automatically created in the system and a new animal number is issued and registered at the same time.

Note: When newly creating transmitters and animal numbers, the animal number will either be produced consecutively or as a part of the transmitter number (see **6.1.3** Assigning animal numbers, page **85**). Clarify whether this kind of number assignment is actually what the end users wants.

Proceed as follows to create transmitter numbers and automatically register calves:

1. Choose  > **Animal management** > **Register** to go to the **Automatic** submenu.
2. In **Mode** select the **All** option.
3. In **Group**, choose the group in which you want to automatically register the calves.

Note: Calves **without collars** should never be in the bay. They could push other animals out of the way and steal remaining amounts of feed.

6.3 Canceling animals or animal groups

Individual calves or a group of calves that are no longer being fed according to the plan must be removed from the pen compartment and their registration canceled. The same applies to calves whose feeding plan has expired.

6.3.1 Canceling an individual animal's registration

You cancel an individual animal's registration as follows:

1. Choose  > **Animal management** > **Cancel** to go to the **Animal** submenu.
2. Select the desired animal number.
3. In the **Plan end** menu, you check how much longer the calf is to be fed according to the plan.

4. In the **MP** menu, you can check how much milk powder the calf has consumed from the start of registration to its cancellation.
5. Confirm **cancel?** by choosing in order cancel a calf.

ATTENTION There is a risk of malnutrition if calves do not receive any feed. Malnutrition can cause impaired growth and development, increased susceptibility to illness or even death of the calves. Inform the end user that he/she must provide the canceled calves with feed using an alternative method.

Note: If you have chosen the value **All** or **Available** for the **automatic registration mode**, the end user should remove unregistered calves from the bay, because otherwise they will be automatically registered again.

6.3.2 Canceling a group registration

You can cancel a group registration as follows:

1. Choose  > **Animal management** > **Cancel** to go to the **Group** submenu.
2. Select the required group.
3. In **Registered**, you can see how many calves are being fed according to the corresponding plan.
4. In **Weaned** you can see how many calves have finished the feeding plan and are therefore no longer receiving any feed.
5. Confirm **Cancel?** with if all calves of the group are to be canceled regardless of whether they are registered or weaned calves.
6. Confirm the security prompt **Cancel animals in group?** by choosing .

6.3.3 Canceling the registration of weaned animals



You can cancel the registration of weaned calves as follows:

1. Choose  > **Animal management** > **Cancel** to go to the **Weaned animals** submenu.
2. Confirm **Cancel?** by choosing if you want to cancel weaned calves.
3. Confirm the security prompt **Cancel animals?** by choosing .

6.4 Transferring animal registrations

You can transfer calves registered at an automatic feeder to another group at any time.

To transfer a registered calf to another group, proceed as follows:

1. Choose  > **Animal management** to go to the **Transfer** submenu.
2. Select the desired calf.
3. Select the desired feeding group in **Group**.
4. Confirm the prompt **Register animal xx in group X?** by choosing .

Note: When registration is transferred, the feeding day is retained; the calf will **not** be reset to the start of the feeding plan (= to plan day 1).

7 Shutting down and recommissioning the automatic feeder

This chapter explains how to shut down the automatic feeder temporarily or permanently and recommission it.

7.1 Shutdown

You can shut down the automatic feeder temporarily or permanently.

To make the procedure easier and ensure that you do not miss any steps, see the check list **Shutting down the automatic feeder** in the appendix (see chapter 9.3 Automatic feeder shut-down checklist, page 131).

7.1.1 Temporary shutdown

You can temporarily shut down the automatic feeder, for example from the end of one calving season to the start of the next.

If you are shutting down the automatic feeder for a prolonged period of more than one year, you should store the feeder in an upright position in a clean, dry and frost-free location.

In addition, observe the following rules when transporting the automatic feeder:

- **▲ CAUTION** **Health hazards** caused by lifting heavy loads. Do not move the automatic feeder by yourself.
- The automatic feeder must always be transported in an upright position.

To ensure that the automatic feeder does not become a breeding ground for germs, which could endanger the health and life of the calves when you recommission the feeder, you must thoroughly clean the automatic feeder before shutting it down.

Depending on how the automatic feeder is configured, you must run the manual or automatic cleaning programs for the mixer, heat exchanger, hoses, teat and powder container.

After cleaning, you must disconnect the power and water supplyboilerseal the cable glands for antennas and the Ethernet connection with dummy plugs and drain the water from the magnetic valves and the volume control valve.



To shut down the automatic feeder, proceed as follows:

▲ WARNING Beware of **Chemical burns** from cleaning agents. The cleaning agent can cause chemical burns to your eyes or hands. Always wear goggles and chemical-proof protective

gloves when disposing of cleaning agents. Follow all the safety instructions listed in the safety data sheet for the cleaning agent and wear the specified safety equipment.

1. Start the maximum number of cleaning programs (see **Cleaning** chapter in the operating manual for the automatic feeder).
2. Drain the water from the boiler, solenoid valves and the pressure-reducing valve to prevent the automatic feeder from being damaged by frost.

ATTENTION Beware of damage to the automatic feeder. Frozen water expands and can damage automatic feeder components that contain water, such as the solenoid valves.

- 2.1 Close the water tap that supplies water to the automatic feeder.
- 2.2 De-pressurize the hoses by dispensing water into the mixer jar.
- 2.3 Press .
- 2.4 Confirm **Bo. water start?** by choosing .

⚠ DANGER Beware of **lethal electric shock**. The electrical components of the automatic feeder are live. Before continuing, always turn off the automatic feeder using the control switch and disconnect the power plug.

3. Turn off the automatic feeder with the control switch and disconnect the power plug.
 - 3.1 Disconnect the water hose between the solenoid valve for water and the boiler .
 - 3.2 Open the vent screw on the cover of the boiler. As soon as air flows in, the water will drain.
 - 3.3 Let the water drain completely.
 - 3.4 Reattach the water hose and tighten the vent screw.
4. Disconnect the water hose from the water tap that supplies the automatic feeder with water and from the water connector on the automatic feeder.
5. Dispose of the water hose.

ATTENTION Beware of the risk of infection. To prevent infections, use a new hose when recommissioning the unit.

6. Pour the liquid from the mixer into a container or the drain.
7. Remove the teat from the feeding box.

8. Dispose of the teat.

ATTENTION Beware of the risk of infection. To avoid infections, use a new teat when recommissioning the unit.

9. Disconnect the hose from the teat to the feeding box valve or the mixer jar.

10. Dispose of the hose.

ATTENTION Beware of the risk of infection. To prevent infections, use a new hose when recommissioning the unit.

11. Disconnect the hose that runs from the drain channel to the mixer drain valve.

12. Dispose of the hose.

ATTENTION Beware of the risk of infection. To prevent infections, use a new hose when recommissioning the unit.

13. Seal the cable gland of the Ethernet connection with a dummy plug and close the antenna connections using the locks.

ATTENTION Moisture can enter the control box through the cable glands of the Ethernet connection and damage it.

14. Clean the outside of the automatic feeder using a damp cloth. Clean all areas that are not reached by the cleaning program.

ATTENTION High-pressure sprays can **damage** the automatic feeder. Only clean the automatic feeder by hand using a damp cloth.

15. Empty the powder container.

16. Remove the screws holding the safety grid on the powder container. Remove the safety grid.

17. Empty the detergent tank (optional).

⚠ WARNING Beware of **Chemical burns** from cleaning agents. The cleaning agent can cause chemical burns to your eyes or hands. Always wear goggles and chemical-proof protective gloves when disposing of cleaning agents. Follow all the safety instructions listed in the safety data sheet for the cleaning agent and wear the specified safety equipment.

18. Clean the powder container and dosing unit (see **Cleaning** chapter in the operating manual for the automatic feeder). To do this, use the scraper supplied.

19. Cover the automatic feeder with a tarpaulin. This will protect it from dirt.

7.1.2 Permanent shutdown

If you are going to permanently shut down the automatic feeder, you must dispose of it in accordance with the law. To find out which regulations apply to you, contact your waste disposal company or a waste disposal center listed in the yellow pages.

In the appendix of this manual, you will find a list of the materials used in the construction of the automatic feeder (see chapter **9.2** Automatic feeder material list, page **130**).

- Perform steps 2 to 18 of the shutdown (see chapter **7.1.1** Temporary shutdown, page **93**). You do not have to perform step 1, cleaning.
- Dispose of any residual cleaning agent. See the data sheet of the cleaning agent for information on the disposal of the cleaning agent.

⚠ WARNING Beware of **Chemical burns** from cleaning agents. The cleaning agent can cause chemical burns to your eyes or hands. Always wear goggles and chemical-proof protective gloves when disposing of cleaning agents. Follow all the safety instructions listed in the safety data sheet for the cleaning agent and wear the specified safety equipment.

- Dispose of the automatic feeder as described in the disposal chapter in the operating manual for the automatic feeder.

7.2 Recommissioning

7.2.1 Recommissioning after temporary shutdown without change of location

In the following description, we are assuming that you have only disconnected your automatic feeder from the water and power supply.

You can reconnect these lines yourself. To make the procedure easier and ensure that you do not miss any steps, see the check list for recommissioning the automatic feeder (see chapter **9.1** Checklist for commissioning and recommissioning, page **125**) in the appendix.

Proceed as follows to recommission the automatic feeder:

1. Remove the cover.
2. Clean the outside of the automatic feeder with a damp cloth.
3. Install the safety grid for the powder hopper attachment. Screw the screws back into the holes provided. The safety grid for the powder hopper attachment prevents you from being injured by the rotating tools in the powder hopper, for example, when adding milk powder.

4. Connect the water connector of the automatic feeder to the water tank using a clean new water hose.
5. Put the detergent supply into operation again.
6. Connect the teat to the feeding box valve (rationed mode) or the mixer jar (ad lib mode). Use a new hose for this connection.

ATTENTION The hose must be installed at a gradient to the automatic feeder without sagging. This makes it easier for calves to consume feed and makes it easier to drain the hose (see the illustration).

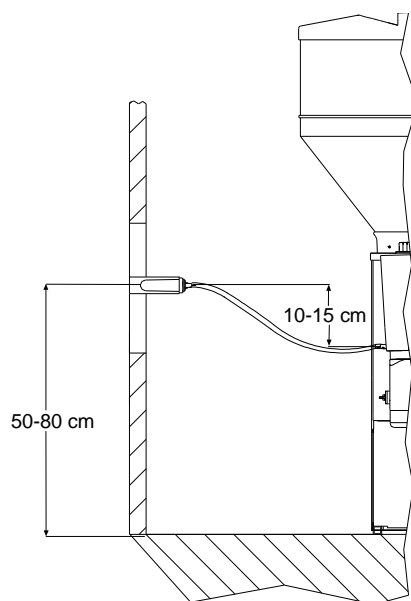



Hose with gradient between teat and feeding box valve

7. Connect the mixer drain valve to the drain channel. Use a new hose for this connection.
 8. Remove the dummy plugs for the Ethernet Cable and replace them with a grommet.
 9. Remove the locks on the antenna connections and connect them to the antennas.
 10. Plug the power plug into the power outlet.
 11. Switch on the automatic feeder using the control switch.
- Fault, Boiler not filled** appears in the display of the hand terminal.
12. Press .
 13. Confirm **Boiler: Fill?** by choosing .

The boiler is automatically filled with water.

14. Choose  > **Device data** to go to the **Time** or **Date** submenu.

- In the **Time** menu, you enter the time of day using the number keys.
- In the **Date** menu, you enter the time of day using the number keys.
- In the **Format** menu, you use   to select the desired date format.

15. Start the maximum number of cleaning programs (see **Cleaning** chapter in the operating manual for the automatic feeder).

Clean the hoses and the powder container.

By doing this, you prevent germs that enter the automatic feeder from multiplying and infecting your calves.

16. Fill the powder container with milk substitute (MP). Use only milk substitute that is suitable for feeding calves.

ATTENTION Make sure that no paper or other foreign bodies enter the powder container. This could damage the dosing mechanism or impair dosing accuracy.

17. Calibrate all feed components (see **3.21** Calibrating feed components, page **40**).

18. Check the setup settings (see **5** Setup, page **71**).



7.2.2 Recommissioning after long-term shutdown or change of location

If your automatic feeder has been shut down for an extended period or moved to another location, you can **recommission** it as follows (see **3** Commissioning, page **27**).

7.2.3 Recommissioning after processor card replacement

After a shutdown, for example after replacing the processor board, you must set up the device data again.

Proceed as follows:

1. Switch on the automatic feeder using the control switch.
2. Confirm the message **first startup press enter to start installation** by choosing .
The message **restore last backup?** will appear if there is a valid backup of the animal and device data in the automatic feeder.
3. Confirm **restore last backup?** by choosing .

The animal data and device data from the last backup will be restored.

Note: If no data is present, follow the same steps as in commissioning (see **3 Commissioning**, page **27**).

4. In the **Basic settings** menu, enter the desired language, the current date and the current time of day.

This concludes the recommissioning process.

8 Faults and warnings



The automatic feeder shows fault messages or warning messages in the display to indicate faults during feeder operation.

In the event of a **fault**, automatic mode is interrupted and no feed is prepared.

ATTENTION An interruption in feeding operation means that your calves will not receive any feed. This can lead to malnutrition. Malnutrition can cause impaired growth and development, increased susceptibility to illness or even death of the calves. Inform the end user that he/she must provide the calves with feed using an alternative method if feed operation is interrupted.

In the case of a **warning**, automatic mode will not be interrupted and feeder operation will continue.

Once you have eliminated the fault, delete the fault and warning messages.



- Some fault and warning messages are deleted automatically.
- Some fault and warning messages can be deleted by pressing .
- Some fault and warning messages are deleted by confirming **Delete fault?** or **Delete warning?** by choosing .

8.1 Faults

8.1.1 Calibration scale

If the calibration scale was not adjusted during setup, you will see **Fault, calibration scale** in the display.

You correct the fault as follows:

1. Confirm **Calibration scale** with .
2. Press **adjust?**  to adjust the calibration scale.
3. The adjustment process begins with the taring of the calibration scale. You will be informed of this in the **calibration scale will be tared** message.
4. A menu appears where you need to enter the reference weight in grams that you require for the adjustment. If necessary, adapt the respective value in this menu (default value: 500 g).

Note: A 500 g reference weight is included in the delivery.

5. Place the reference weight with the hole on the screw in the feeding box such that it is fixed in place, and then press in order to start the adjustment process.
6. After completing the adjustment process, a corresponding message about the success or lack of success of the adjustment will be issued. At the same time, the currently determined weight value will be shown. After removing the calibration weight, 0 grams should be shown here.
7. Press . **Date** now shows the current date.

8.1.2 Heating

Fault heating xx.x °C will be shown in the display if the temperature of the boiler water is too low. Feeder operation will be interrupted until the set minimum temperature has been reached. Make sure that the end user provides the calves with feed using an alternative method as long as feed operation is interrupted.

You correct the fault as follows:

If heating up the boiler water does not solve the problem:

1. Choose  > **Device data** > **Portion** to go to the **Set temp.** or **Min. temp.** submenu and check the temperature settings.
2. Check that the heater is working properly.

8.1.3 Temperature too high

Fault, temperature too high will appear in the display when the water temperature in the boiler is too high. Feeder operation will be interrupted until the water in the boiler has cooled to the set maximum temperature. Make sure that the end user provides the calves with feed using an alternative method as long as feed operation is interrupted.

You correct the fault as follows:

1. Confirm **Fault, temperature too high** by choosing .
2. In **Boiler water start?**, press & hold .
3. Drain water from the boiler into the mixer jar until the fault message disappears.
4. Confirm **Mixer: empty?** by choosing .

Check the temperature of the supplied water if the Boiler is supplied with preheated water.

8.1.4 Boiler not filled

When you turn on the automatic feeder, the control unit checks whether the **boiler** is filled with water. If it is not filled, feeder operation will be interrupted and the message **Fault, Boiler not filled** will appear in the display.

Feeder operation will be interrupted. Make sure that the end user provides the calves with feed using an alternative method as long as feed operation is interrupted.

You correct the fault as follows:

1. Confirm **Fault, boiler not filled** by choosing .
2. Check the water supply
3. In the **Fill Boiler** menu, press .
4. Check whether the water jet hits the rod electrode and the display shows **covered**.
5. Check that the shutoff valves and the drain valve are not leaking.

Note: If liquid in the mixer is flowing out through these valves, the rod electrode cannot be grounded (see **8.1.5 Water shortage**, page **103**).

If the fault persists, proceed as specified in “Water shortage”, page 103.

8.1.5 Water shortage

If the rod electrode is not grounded in the mixer jar when water is being added, a water test will be started. If the water test is not successful, then feed preparation and animal identification will be switched off. **Fault, water shortage** appears in the display.

Feeder operation will be interrupted. Make sure that the end user provides the calves with feed using an alternative method as long as feed operation is interrupted.

You correct the fault as follows:

1. Confirm **Fault, water shortage** by choosing .
2. Confirm **Boiler water start?** by choosing .
3. Check whether the water jet hits the rod electrode.
4. Check the water supply to the automatic feeder.
5. Check whether deposits such as calcium have formed on the electrode.

6. Confirm **Delete fault?** with if you have fixed the fault.

⚠ DANGER Lethal electric shock. The electrical components of the automatic feeder are live. Always turn off the automatic feeder using the control switch and disconnect the power plug before you change the sensitivity of the electrode.

Check and change the response sensitivity of the electrode.

1. Choose  > **Diagnosis > Sensors** to go to the **EI. rod** submenu.

2. In the right-hand column, check the status (**free** or **covered**).

3. Confirm **EI. rod** by choosing .

3.1 In **Status**, check the status (**free** or **covered**).

3.2 Confirm **Boiler water, start?** by choosing .

The electrode will be triggered if **water** is dispensed into the mixer jar.

3.3 Confirm **Mixer: empty?** by choosing to pump out the liquid again.

4. Visually inspect the electrode.

4.1 If the electrode reports that it is **covered** although it is actually free, the sensitivity of the electrode is too high.

4.2 Reduce the sensitivity of the electrode by rotating the potentiometer (see machine circuit diagram in the appendix) counterclockwise on the main board.

4.3 If the electrode reports that it is **free** although it is actually covered, the sensitivity of the electrode is too low.

4.4 Increase the sensitivity of the electrode by rotating the potentiometer (see machine circuit diagram in the appendix) clockwise on the main board.

5. Confirm **Delete fault?** with if you have fixed the fault.

8.1.6 Mixer emptying

Fault, mixer emptying will appear if the mixer cannot be drained.

Feeder operation will be interrupted. Make sure that the end user provides the calves with feed using an alternative method as long as feed operation is interrupted.

You correct the fault as follows:

⚠ DANGER Lethal electric shock. The electrical components of the automatic feeder are live. Always turn off the automatic feeder using the control switch and disconnect the power plug before you perform work on the feeder's components.

1. Turn off the automatic feeder using the control switch and disconnect the power plug.
2. Check all components carrying feed from the mixer to the mixer drain valve or from the mixer up to the teat for blockages and remove them.

⚠ ATTENTION The hose from the mixer drain valve to the drain channel may not be lengthened.

3. Check the feeding pump:

3.1 Confirm **Start feeding pump?** by choosing .

4. Check the rod electrode:

4.1 Confirm **Bo. water start?** by choosing to fill the mixer with water.

4.2 In **Mixer emptying?**, confirm by choosing .

5. Confirm **delete fault?** by choosing if you have fixed the fault.
6. Insert the power plug again and turn on the automatic feeder using the control switch.
7. Remove detergent remnants from components carrying feed by rinsing them with water.

⚠ ATTENTION Detergent remnants that enter the feed can be hazardous to the health of calves. Remove detergent remnants before recommissioning the automatic feeder.

8. Return to automatic mode.

8.1.7 Heating

Fault, heating will be shown in the display if the heater is faulty.

Feeder operation will be interrupted. Make sure that the end user provides the calves with feed using an alternative method as long as feed operation is interrupted.

You correct the fault as follows:

⚠ DANGER Lethal electric shock. The electrical components of the automatic feeder are live. Before working on components, always turn off the automatic feeder using the control switch and disconnect the power plug.

- Check whether safety temperature limiter has been triggered.
- Check the temperature sensor.
If the temperature sensor is defective, replace it.
- Check whether voltage is applied to the heater. If necessary, check the fuses provided by the customer (contactor).
- Check the heating rod for continuity.
If the heating rod is defective, replace it.
- Check the setup settings for the heating system.
 - **Setup > Machine > Heating:** mechanical

You reactivate the safety temperature limiter as follows:

⚠ DANGER Lethal electric shock. The electrical components of the automatic feeder are live. Always turn off the automatic feeder using the control switch and disconnect the power plug before you reactivate the safety temperature limiter.

1. Confirm **Delete fault?** with if you have fixed the fault.
2. Turn off the automatic feeder using the control switch and disconnect the power plug.
3. Open the right side door of the automatic feeder.
4. Remove the metal cover under which the safety temperature limiter is located.
5. Press the reset button in order to reset the safety temperature limiter.
6. Reattach the metal cover.
7. Close the side door.
8. Insert the power plug again and turn on the automatic feeder again using the control switch.

8.1.8 Boiler temperature sensor

Fault, Temp. sensor, boiler is shown in the display if the temperature sensor of the boiler is defective.

Feeder operation will be interrupted. Make sure that the end user provides the calves with feed using an alternative method as long as feed operation is interrupted.

You correct the fault as follows:

⚠ DANGER Beware of lethal electric shock. The electrical components of the automatic feeder are live. Always turn off the automatic feeder using the control switch and disconnect the mains plug before you work on the main board.

1. Turn off the automatic feeder with the control switch and disconnect the mains plug.
2. Remove the metal cover on the back of the automatic feeder.
3. Measure the resistance of the temperature sensor on the main board.
4. Compare the measured value with the value in the table. The table can be found in the machine circuit diagram in the appendix.
5. If the measured value differs from the value in the table, you must replace the sensor. (see machine circuit diagram in the appendix).
6. Reattach the metal cover.
7. Insert the mains plug again and turn on the automatic feeder again using the control switch.

8.1.9 Calibration

Fault, calibration will be shown in the display if the liquid or powder feed components and the detergent have not been calibrated.

Feeder operation will be interrupted. Make sure that the end user provides the calves with feed using an alternative method as long as feed operation is interrupted.

You correct the fault as follows:

1. Calibrate all components shown in the display (see **3.21** Calibrating feed components, page **40**).

8.1.10 Box/drain valve

Fault, Box/drain valve is shown in the display if a feeding box valve or the mixer drain valve is leaking. The automatic feeder loses water during cleaning.

Feeder operation will be interrupted. Make sure that the end user provides the calves with feed using an alternative method as long as feed operation is interrupted.

You correct the fault as follows:

1. Check all feeding box valves and the mixer drain valve for leaks.

- 1.1 Clean leaky valves in order to remove any foreign objects that might have entered the system.
- 1.2 Repair leaky valves or replace them.
2. Check the rod electrode.
 - 2.1 Choose  > **Diagnosis > Sensors** to go to the **El. rod** submenu.
 - 2.2 In the right-hand column, check the status (**free** or **covered**).
 - 2.3 Confirm **El. rod** by choosing .
 - 2.4 In **Status**, check the status (**free** or **covered**).
 - 2.5 Confirm **Boiler water start?** by choosing .

The electrode must report that it is **covered** if **water** is dispensed into the mixer jar up to the electrode.

If the fault persists, you must replace the rod electrode.

3. Confirm **Delete fault** by choosing once you have eliminated the fault.

8.1.11 Uncontrolled output

The automatic feeder monitors all outputs during current operation which are responsible for the dispensing of water, milk powder, additives and detergent, as well as the mixer drain valve. If the corresponding relays are actuated for more than 60 seconds, the fault **Uncontrol.**











output will appear in the display. Depending on the type of defect, one of the following fault codes will be displayed:

- **Boiler water**, if the boiler water valve is faulty.
- **Mixer drain**, if the mixer drain valve is faulty.
- **Powder**, if the motor of the milk powder conveyor is defective.
- **Additive dispenser**, if the additive dispenser is defective.

Feeder operation will be interrupted. Make sure that the end user provides the calves with feed using an alternative method as long as feed operation is interrupted.

You correct the fault as follows:

- Check the water valve of the boiler.

- 1 Choose  > **Diagnosis** to go to the **Valves** submenu.
 - 2 Confirm **Bo. water open?** by choosing  to open the water valve. The valve remains open as long as you hold down .
 - 3 Check whether the valve opens. The valve opens when the water is dispensed.
 - 4 If a valve is defective, repair or replace it.
- Check the mixer drain valve.
 - 1 Choose  > **Diagnosis** to go to the **Valves** submenu.
 - 2 Confirm **Mixer drain open?** by choosing  to open the mixer drain valve. The valve remains open as long as you hold down .
 - 3 Check whether the valve opens. The valve opens when the water drains.
 - 4 If a valve is defective, repair or replace it.
 - Check the motor of the milk powder conveyor.
 - 1 Choose  > **Diagnosis** to go to the **Motors** submenu.
 - 2 Confirm **Powder start?** by choosing  in order to start the motor of the powder conveyor.
 - 3 If the motor does not start, check the plug on the powder conveyor or check the power supply.
 - Check the additive dispenser.
 - 1 Choose  > **Diagnosis** > **Motors** to go to the **Additive** submenu.
 - 2 Confirm **Start?** with  to start the additive conveyor motor.
 - 3 If the motor does not start, check the plug or the power supply.

8.2 Warnings

8.2.1 Mixer emptying

Mixer emptying warning appears if the mixer cannot be drained. For example, this can be because the drain is clogged or the feeding pump is no longer running.

⚠ DANGER Lethal electric shock. The electrical components of the automatic feeder are live. Before working on components, always turn off the automatic feeder with the control switch and disconnect the power plug.

You rectify the warning as follows:

1. Check all components carrying feed from the mixer to the mixer drain valve or from the mixer up to the teat for clogs and remove them.

ATTENTION The hose which goes from the mixer drain valve to the drain channel must not be lengthened.

2. Check the feeding pump.

2.1 Confirm **Mixer emptying warning** by choosing .

2.2 Confirm **Feeding pump: start?** by choosing .

The feeding pump will be actuated.

3. Check the rod electrode.

3.1 Visually check the rod electrode for deposits.

3.2 Check that the rod electrode works properly (see **8.5.3** Checking sensors, page **120**).

4. Fill and drain the mixer.

4.1 Confirm **Boiler water, start?** by choosing .

The mixer will fill up with water.

4.2 Confirm **Mixer: empty?** by choosing .

The mixer will be drained.

If the fault has been fixed, confirm the message **Delete warning?** in the display with .

8.2.2 Mixer temperature sensor

The **Mixer temp. sensor warning** will be shown in the display if the temperature sensor in the mixer jar is faulty or the temperature of the mixed feed in the mixer jar drops below 0 °C.

You rectify the warning as follows:

Use a ohmmeter to measure the voltage at the input of the temperature sensor on the board. Compare the measured value with the value in the circuit diagram, and if it is different, replace the temperature sensor (see circuit diagram provided).

8.2.3 Identification

Warning, identification appears in the display if animal identification is not working.

You eliminate the warning as follows:



Check the cables leading to the antenna. Repair any damage or replace the cables or antennas.

8.2.4 Incorrect ID

All CAN nodes have a unique ID which cannot be changed. The ID is used to automatically check whether the right node reports on the CAN address. If this is not the case, it is possible for the feeder and the node to communicate, but there will be no proper data exchange. **Warning, Incorrect ID** appears in the display.

You eliminate the warning as follows:

Check all CAN addresses.

1. Switch on the feeder and hold down the  button until the setup menu appears in the display.
2. Go to **Setup > Boxes** and check the **CAN addresses** of the individual CAN nodes.
3. To exit the setup, press  until the message **Exit setup?** appears. Confirm this by choosing .

If IDs have changed, e.g., for reasons of compatibility, you must update all CAN nodes. To do this, use an SD card or FlashManagerPlus.

8.2.5 Address used twice

If two or more nodes are linked together in a bus system, it can happen that one CAN address is issued twice. **Warning, address used twice** appears in the display.

You rectify the warning as follows:

1. Confirm **Warning, Address used twice** by choosing .
The CAN node with the double address will be displayed.
2. Choose **Setup > Boxes** to open the submenu shown in the display with the double address.

3. Assign another address which is still available to the CAN node with the double address. For more information on assigning CAN addresses, see the **Setup > Address** chapter (see **5.4.3 Feeder address**, page **75**).

Note: If possible, use an address from the standard range of numbers for the CAN node concerned.

4. Confirm your changes by choosing .
5. To exit the setup, press until the message **Exit setup?** appears. Confirm this by choosing .
6. Delete the warning on all feeders.

8.2.6 Unknown transmitters

The **Unknown transmitters warning** appears in your display:

- If a transmitter is detected by the identification unit for which no animal number has been assigned.
- If a transmitter number has been allocated to an animal number, but has still not been registered.

You rectify the warning as follows:

1. Confirm **Unknown transmitters warning** by choosing .
2. In **No.**, you check the unknown transmitter number.
3. In **Number**, you check how often the unknown transmitter number has been identified.
4. In **Time**, you check when the transmitter was last registered by the identification system.
5. Confirm **delete?** by choosing if you want to delete the transmitter number.
6. Confirm **Register** by choosing if you want to allocate the unknown transmitter number to an animal number.

8.2.7 Calibration

The **calibration warning** will appear in your display if the last calibration was 120 days ago or if automatic calibration failed. You will see which components you have to calibrate.

You rectify the warning as follows:

1. Calibrate all components shown in the display (see **3.21** Calibrating feed components, page **40**).
2. Confirm **delete warning?** by choosing .

Note: If you delete the warning without calibrating, the message will appear again the next day.

8.2.8 Calibration scale

The **calibration scale warning** will appear in your display if your calibration scale is not working.

ATTENTION There is a risk of malnutrition caused by incorrectly dispensed feed portions. Malnutrition can cause impaired growth and development, increased susceptibility to illness or even death of the calves. You must ensure that the end user provides his/her calves with feed using an alternative method as long as the calibration scale is not working.

You rectify the warning as follows:

⚠ DANGER Lethal electric shock. The electrical components of the automatic feeder are live. Before working on components, always turn off the automatic feeder using the control switch and disconnect the power plug.

1. Check whether the circuit board for the mixer scale is correctly plugged onto the main board of the feeder.
2. Check the cables which go to the calibration board as well as to the load rod for visible damage (for example, animal bites).
3. Check the load rod and the calibration unit of the mixer scale.

Note: The warning is automatically deleted when the fault has been rectified.

8.2.9 Double animal number

Warning, double animal no. will appear in your display if the same number was assigned twice during the fully automated registration process.

You change the double animal number as follows:

1. Confirm **Double animal no. warning** with

The **Double** menu in animal control appears (see the **Animal control > Double** chapter in the operator's manual).

2. In **No.**, the full transmitter number of the animal appears.
3. In **Animal no.**, change the automatically assigned number.
4. In **Time** and **Date**, check when the double animal number appeared.
5. Once you have changed the animal number, confirm **confirm?** by choosing .

Note: Only when you have changed the animal number will your confirmation take effect and the warning be deleted.

8.2.10 Machine capacity

Warning, Machine capacity will appear when there is no more storage space available for transmitter numbers.

Confirm **Machine capacity** by choosing in order to view detailed information.

- **only 50 animals poss.** means: No more free animal numbers are available.
- **Transmitter storage full** means: No more storage space available for further transmitter numbers.

You rectify the warning "only 50 animals possible" as follows:

1. Cancel one or more animals in the **Animal** menu (see operating manual).

ATTENTION When you cancel an animal's registration it will not receive any feed. This can lead to malnutrition. Malnutrition can cause impaired growth and development, increased susceptibility to illness or even the death of your calves. The end user must use an alternative method to supply their calves with feed.

2. Confirm delete warning? by choosing .

You rectify the warning "transmitter storage full" as follows:

1. Choose  > **Animal management > Transmitters** to go to the **Edit** submenu.
2. Select the transmitter number to be deleted and confirm **Delete** by choosing .

Note: You can only delete transmitter numbers of calves that are not registered (= status: available).

3. Confirm **delete warning?** by choosing .

8.2.11 Check SD card

The **Check SD card** warning appears in your display:

- If data is to be saved manually, but no SD card is present.
- If data is to be saved manually, but the SD card is currently write-protected.
- If data is to be saved automatically but the SD card is full.
- If data is to be saved automatically but the SD card is currently write-protected.

8.3 Other faults and messages

8.3.1 Automatic feeder

8.3.1.1 Starting program

The message **Smart Vxx.xx starting program** appears when the control program of the automatic feeder starts.

Wait until the automatic feeder is ready to operate.

8.3.1.2 Initialization of the feeder

The message **first startup, press enter to start installation** will appear in the display in the following cases:

- When the automatic feeder starts for the first time.
- If the computer card must be replaced due to a hardware defect.

Follow the instructions on the screen. The following steps can be performed in the course of the initialization:

- > Restoration of the last backup (if available).
- > Entry of the language for the user interface.
- > Entry of the current date and time.

8.3.2 Hand terminal

8.3.2.1 CAN bus off

If a short circuit or electromagnetic discharges negatively affect the CAN cable, the message **terminal Vxx.xx CAN bus off** will appear in the display.

You correct the fault as follows:

Check the CAN bus for short circuits and other faults and correct them.

8.3.2.2 CAN bus heavy

The following faults trigger the message **terminal Vxx.xx CAN bus heavy** :

- Short circuit.
- Terminating resistor not set.
- Break in the data line.
- CAN cable incorrectly attached.
- No connection for automatic feeder control unit.

You correct the fault as follows:

- Check the CAN bus for short circuits.
- Check whether the terminating resistor has been properly set.
- Check whether the data line has been interrupted.
- Check whether the CAN cables are correctly connected.
- Check whether the data line is correctly wired and that the feeder control is working.

8.3.2.3 Waiting

The following faults prevent the hand terminal from initializing:

- The CAN bus address of the terminal is not the same as the one defined in setup of the of the automatic feeder.
- The feeder control unit is not active.

The message **terminal Vxx.xx waiting** appears.

You eliminate the faults as follows:

1. Start search mode: Press when you switch on the feeder and keep this key pressed.
2. When the display reappears, you have to check whether the feeder control is working.

8.3.2.4 Searching

When the hand terminal is in search mode, the message **terminal Vxx.xx searching** will appear.



You correct the fault as follows:

- Check whether the feeder is working.
- If the message is not automatically hidden in about ten seconds, you must check the feeder control.

8.3.3 Bootloader

8.3.3.1 Waiting for update

The following faults trigger the message **bootloader Vxx.xx waiting for update**:

- The automatic feeder's control program is not able to run.
Update the program using an SD card or FlashManagerPlus.
- The bootloader was (accidentally) activated while switching on.
If the bootloader was accidentally started during the start of the automatic feeder by pressing and holding  , you have to restart the automatic feeder.

8.3.3.2 Flash programming

The message **bootloader Vxx.xx flash programming** will appear while the program is being updated.

Wait until the update has been completed.

8.3.3.3 Starting program

The message **bootloader Vxx.xx starting program** will appear when the bootloader for the automatic feeder starts.

Wait until the program has started.

8.4 Service messages

A service message appears in the automatic feeder's display every 4 months. This message indicates the maintenance (regular service) that must be performed. Compliance with these

maintenance intervals is the only way to ensure the long life and reliability of the automatic feeder.

The following regular services (RS) have been defined:

- RS1 must be performed every 4 months.
- RS2 must be performed every 12 months.
- RS3 must be performed every 36 months.

Via **Setup > Service > last**, check when the last regular service was carried out and in **Type**, check what sort of regular service it was (RS1, RS2 or RS3).

Go to **Setup > Service > next** to check when the next regular service is due and go to **Type** to check what sort of regular service is required (RS1, RS2 or RS3).

8.4.1 Service work

For each regular service, there are various service packages (sets of spare parts) with the spare parts required, which will differ, depending on the type of feeder and type of service. After replacing the parts subject to wear, you must also check that the feeder is working properly e.g. the calibration. The service work is described in the installation information for the sets of spare parts.

You can collect the corresponding service packages (sets of spare parts) via a regular service configuration tool which is available in the dealer area of Förster-Technik's web site (www.foerster-technik.de).



Configurator Service packages

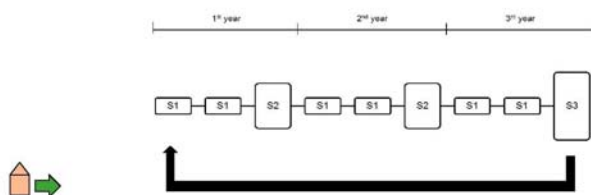

After doing the regular service, under **Setup > Service > Serv. done?** confirm the message **Use today's date as regular service date?** with .

Note: This service message will be shown in the display for 3 days and will then disappear until the next regular service is due. It can be deleted earlier by pressing ; however, it will be re-created every day within these 3 days.

8.5 Diagnosis

The **Diagnosis** menu helps you to find faults in the event of technical problems. You can reach this menu via . A diagnosis can be performed for the following parts of the automatic feeder:





- Valves
- Motors
- Heating
- Sensors
- Control system
- Version
- Setup
- Software

8.5.1 Checking valves/motors

In this menu, you check actuators (valves and motors) and their actuation.

8.5.1.1 Valves

Check the valves as follows:

1. Choose  > **Diagnosis** to go to the **Valves** submenu.
2. Confirm **Bo. water open?** by choosing  to open the water valve. The valve remains open as long as you hold down .
3. Confirm **Mixer drain open?** by choosing  to open the mixer drain valve. The valve remains open as long as you hold down .
4. Check whether the valve opens.

8.5.1.2 Motors

Check the motors as follows:

1. Choose  > **Diagnosis** to go to the **Motors** submenu.
2. Confirm **Mixer start?** by choosing in order to start the mixer.
3. Confirm **Start powder?** with to start the powder conveyor.
4. Confirm **Feeding pump start?** by choosing in order to start the feeding pump.

8.5.2 Checking the heating

In this menu, you check the boiler heater.

Check the boiler heater as follows:

1. Choose  > **Diagnosis** to go to the **Heating** submenu.
2. Confirm **switch on?** by choosing .
3. In **Boiler**, you check the temperature.
4. If you hold down in **switch on?**, the boiler is heated up. If the temperature rises, the heater is working.

8.5.3 Checking sensors

In this menu, you check the sensors of the following components:

- Rod electrode.
- Button for the manual feeding pump (active/inactive).
- Mixer and boiler (temperatures of the liquids in the boiler and in the mixer jar).

8.5.3.1 Rod electrode

Check the electrodes as follows:

1. Choose  > **Diagnosis** > **Sensors** to go to the **Rod electrode** or **Point electrode** submenu.
2. In the right-hand column, check the status (**free** or **covered**).
3. Confirm **Rod electrode** or **Point electrode** by choosing .
- 3.1 In the **Status** menu, check the status (**free** or **covered**).

- 3.2 Confirm **Boiler water start?** by choosing .

The electrode will be triggered if **water** is dispensed into the mixer jar.

- 3.3 Confirm **Mixer: empty?** by choosing  to pump out the liquid again.

8.5.3.2 Button for the manual feeding pump

Check the button as follows:

1. Choose  > **Diagnosis > Sensors** to go to the **MP button** submenu.
2. In the right-hand column, check the status (**active** or **inactive**).

8.5.3.3 Temperature in the mixer and boiler

Check the temperature of the liquid in the mixer or boiler as follows:

1. Choose  > **Diagnosis > Sensors** to go to the **Boiler** or **Mixer** submenu.
2. Check the temperature in the right-hand column.

8.5.4 Checking stations

In this menu, you check the feeding box(es).

- > You check whether the identification system of the feeding box works.
- > You can open the feeding box valve.
- > In the display, you can view the control unit assigned to the feeding box.



You check the identification system of a feeding box as follows:

1. Choose  > **Diagnosis > Boxes > Feed** to go to the **Feeding box 1** or **Feeding box 2** submenu.
2. To check the identification (antenna test), hold a transmitter near the antenna.
3. In **No. ⚡**, you check the transmitter number.

If the transmitter number is not recognized, proceed as follows:

- > Check in the setup whether the correct identification system is configured.
- > Check that the data lines between antenna and automatic feeder are undamaged.
- > Check the setup for the allocation of the station that is causing identification problems.

You check the feeding box valve as follows:

1. Go to  > **Diagnosis > Boxes > Feed**.
2. Confirm **open?** for the valve concerned by choosing .
3. Check whether the valve opens.



8.5.5 Control

In this menu, you check the following faults:

- How often the automatic feeder was without power (**power failures**).
Note: Switching on and off are also considered to be power failures.
- How often the feeder control unit had to be restarted after a program error (**Reset**).
- How often the connection to the **terminal** was faulty.
- How often an error occurred in connection with the **database**.
- How often the automatic feeder received no response from the **identification** system.
- How often the minimum temperature in the boiler was not met (**heating**).
- How often the water test was negative (**water shortage**).
- How often the mixer could not be drained via the mixer drain valve (**mixer emptying**).
- How often the **heating** function was faulty.
- How often faults occurred during automatic cleaning of the mixer (**cleaning**).
- How often implausible values were reported by the **temperature sensors** in **Boiler** and **Mixer**.
- How often the **temperature** of the boiler water was **too high**. e.g., if the automatic feeder was supplied with hot water.
- How often a CAN node is registered with the incorrect CAN address (**incorrect ID**).
- How often the automatic feeder could not switch to automatic mode because, for example, the liquid and powder feed components were not calibrated (**calibration**).
- How often the same address has been assigned in the CAN bus to devices (**double address**).

- How often **Unknown transmitters** have been detected by the identification system.
- How often it has been indicated that an animal number has already been assigned (**double animal no.**).
- How often the **detergent** empty indicator was displayed.

You check the faults as follows:

1. Via  > **Diagnosis** go to the **Control** submenu.
2. Select the fault that occurred.
 - In **Number**, you check how many times the failure occurred.
 - In **since**, you check when the entries were deleted the last time.
 - In **last on** or **last at** you can determine the day on which or the time at which a certain event last occurred.
3. Confirm **delete?** by choosing  in order to delete the fault message.

8.5.6 Version

In the **Version** menu, you can check version numbers. The following units have a version number:

- Feeder
- Processor
- Terminal
- Identifications at existing feeding stations.
- Peripherals

Check the version as follows:

1. Choose  > **Diagnosis** to go to the **Version** submenu.
2. Go to the desired submenu and read the version number.

8.5.7 Setup

You can only view the settings in this menu. To make changes, you must open the setup menu. (see **5 Setup**, page **71** and following pages)

You check the setup settings as follows:

1. Choose  > **Diagnosis** to go to the **Setup** submenu.
2. Go to the desired submenu and check the settings.

8.5.8 Software

This menu is only intended for the manufacturer's development department.

8.5.9 Remote maintenance

During the remote maintenance the automatic feeder is operated via the CalfCloud.

1. Move via  > **Diagnosis** to the submenu **remote control**.
2. Click **start?** to allow the remote maintenance of the automatic feeder.
3. Click **terminate?** to terminate the remote maintenance of the automatic feeder.
4. **Status** shows you the current status of the connection to CalfCloud. **Online**, **offline** or **re-connecting** can be displayed.
5. **Service-ID** shows you the unique Service-ID of the automatic feeder.

Note: The remote maintenance starts after you have keyed in the Service-ID in CalfCloud.

9 Appendix

Note: The following checklists and overviews also include additional equipment. If this equipment is not present in your specific case, skip the irrelevant items on the list.

9.1 Checklist for commissioning and recommissioning



Note: Before each initial startup or restart of the automatic feeder, you must carefully read and observe the operating manual, particularly the safety information.

General tasks		OK?
1.	Inform the end user that the automatic feeder must be installed in a frost-proof location or must be fitted with frost protection equipment.	<input type="checkbox"/>
2.	Inform the end user that he/she must ensure appropriate lightning protection (e.g., lightning protection system for the entire building).	<input type="checkbox"/>
3.	Tell end users that the automatic feeder must be protected from rain and moisture.	<input type="checkbox"/>
4.	Tell the end user that the water should be of drinking water quality. Excessive calcium and/or iron and/or manganese concentrations may cause premature wear.	<input type="checkbox"/>
5.	Tell end users that the hose which goes from the mixer drain valve to the drain shaft may not be lengthened.	<input type="checkbox"/>
6.	Tell end users that the feeder and cables are to be protected against exposure to sunlight.	<input type="checkbox"/>
7.	Set up the automatic feeder on an even surface.	<input type="checkbox"/>
8.	Electrically ground the automatic feeder.	<input type="checkbox"/>
9.	Shorten the drain hose.	<input type="checkbox"/>
10.	Connect water supply.	<input type="checkbox"/>
11.	Connect drain.	<input type="checkbox"/>
12.	Install feeding box and feeding station.	<input type="checkbox"/>
13.	Connect antennas and Ethernet cable.	<input type="checkbox"/>
14.	➕ Install concentrate station (including antennas) and fill concentrate container.	<input type="checkbox"/>
15.	➕ Install animal scales: install scale control(s), install weighing platforms in the stands.	<input type="checkbox"/>
16.	Install suction hoses.	<input type="checkbox"/>
17.	Install safety grid for the powder hopper attachment.	<input type="checkbox"/>
18.	Fill MP container.	<input type="checkbox"/>
19.	Install the external detergent supply.	<input type="checkbox"/>
20.	Check switch setting for heating cable, condensation prevention heating and mixer jar heating.	<input type="checkbox"/>
21.	Connect power supply.	<input type="checkbox"/>

22.	Switch on automatic feeder.	<input type="checkbox"/>
23.	Fill boiler with water.	<input type="checkbox"/>
24.	Reinstall device data.	<input type="checkbox"/>
Setup		OK?
1.	Switch off automatic feeder at the main switch and switch on again; while doing this press and hold  .	<input type="checkbox"/>
2.	Check the following settings:	
2.1	Language	<input type="checkbox"/>
2.2	Check time/date, set if necessary.	<input type="checkbox"/>
2.3	Machine	
2.3.1	Assign number and address.	<input type="checkbox"/>
2.3.2	Determine base size.	<input type="checkbox"/>
2.3.3	Heating activated yes/no – mechanical/electronic relay.	<input type="checkbox"/>
2.4	Equipment	
2.4.1	Mixer drain fitted yes/no.	<input type="checkbox"/>
2.4.2	➊ Additive dispenser 1 powder or liquid present yes/no.	<input type="checkbox"/>
2.4.3	Detergent pump fitted yes/no.	<input type="checkbox"/>
2.4.4	Circulation valve fitted no.	<input type="checkbox"/>
2.4.5	Mixer temperature sensor fitted yes/no.	<input type="checkbox"/>
2.5	Identification	
2.5.1	Set type.	<input type="checkbox"/>
2.5.2	Set squelch value.	<input type="checkbox"/>
2.6	➊ Calibration scale	
2.6.1	Activate yes/no	<input type="checkbox"/>
2.6.2	Adjust.	<input type="checkbox"/>
2.7	Stations:	
2.7.1	Activate internal feeding box(es), controlled by feeder.	<input type="checkbox"/>
2.7.2	➊ Configure IFS concentrate station 1(...). Select concentrate feeder type. Issue CAN bus addresses: To do this, put IFS (C-station) into search mode and then, via search? assign address.	<input type="checkbox"/>
2.7.3	➊ Configure scale control(s) 1/x. To do this, set the CAN address on the scale control circuit board via HEX switch and enter the set address in setup. Activate any weighing units (1/2).	<input type="checkbox"/>
2.8	Terminal:	

2.8.1	Assign address	<input type="checkbox"/>
2.9	Communication:	
2.9.1	Institute yes/no	<input type="checkbox"/>
2.9.2	Printer no/serial/CAN.	<input type="checkbox"/>
2.9.3	Configure gateway, parameters.	<input type="checkbox"/>
2.9.4	Configure network	<input type="checkbox"/>
Device data		OK?
1.	Operating modes:	
1.1	Set rationed or ad lib mode.	<input type="checkbox"/>
2.	Set portion:	
2.1	Set the set and minimum temperature.	<input type="checkbox"/>
2.1	Set output pause.	<input type="checkbox"/>
2.1	Set mixer draining and mixer OFF delay	<input type="checkbox"/>
3.	Check time/date.	<input type="checkbox"/>
4.	Assign the function keys	<input type="checkbox"/>
5.	Specify animal list.	<input type="checkbox"/>
6.	Define station parameters:	
6.1	Drain time.	<input type="checkbox"/>
Calibration		OK?
1.	MP	<input type="checkbox"/>
2.	Boiler water	<input type="checkbox"/>
3.	⊕ Additive 1	<input type="checkbox"/>
4.	Detergent	<input type="checkbox"/>
5.	⊕ Concentrate stations	<input type="checkbox"/>
6.	⊕ Settings for automatic calibration of MP/water.	<input type="checkbox"/>

Register		OK?
1.	Antenna test	<input type="checkbox"/>
2.	Set the scheme for the transmitter number assignment: consecutive, automatic.	<input type="checkbox"/>
3.	Read transmitter numbers.	<input type="checkbox"/>
4.	Set registration mode: no, automatic, available transmitter numbers.	<input type="checkbox"/>
5.	Register animals.	<input type="checkbox"/>
Plans		OK?
Feed		
1.	Feeding plans	<input type="checkbox"/>
2.	Concentrate plans	<input type="checkbox"/>
3.	Quantity limitation: check minimum saved amount/maximum saved amount.	<input type="checkbox"/>
4.	Weaning	<input type="checkbox"/>
⊕ Concentrate		
1.	Concentrate plan	<input type="checkbox"/>
2.	Portion size	<input type="checkbox"/>
3.	Quantity limitation: check minimum saved amount/maximum saved amount.	<input type="checkbox"/>
4.	Activate accustoming quantity yes/no.	<input type="checkbox"/>
4.1	Check amount/threshold and adjust if necessary.	<input type="checkbox"/>
Change date of individual animals		OK?
1.	Group	<input type="checkbox"/>
2.	Feed	<input type="checkbox"/>
3.	Concentration	<input type="checkbox"/>
4.	⊕ Concentrate	<input type="checkbox"/>
5.	⊕ Additive 1	<input type="checkbox"/>
6.	Weight	<input type="checkbox"/>
7.	Plan day (correction days)	<input type="checkbox"/>



Cleaning		OK?
1.	Check or make settings:	
1.1	Temperature, cleaning water	<input type="checkbox"/>
1.2	 Detergent amount	<input type="checkbox"/>
1.3	Clean teat	<input type="checkbox"/>
2.	Mixer	<input type="checkbox"/>
2.1	Drainage mode	<input type="checkbox"/>
3.	Cleaning circuit	<input type="checkbox"/>
4.	Suction hose	<input type="checkbox"/>
5.	Perform the cleaning.	<input type="checkbox"/>
Recommissioning		OK?
1.	Set up the automatic feeder.	<input type="checkbox"/>
2.	Clean outside of automatic feeder with damp cloth.	<input type="checkbox"/>
3.	Fit powder hopper attachment safety grid.	<input type="checkbox"/>
4.	Connect water connection of automatic feeder to milk tank using new hose.	<input type="checkbox"/>
5.	Put the detergent supply into operation.	<input type="checkbox"/>
6.	Connect teat to feeding box valve (rationed mode) or to mixer jar (ad lib mode) using new hose. (Install hose with downwards gradient to automatic feeder).	<input type="checkbox"/>
7.	Connect mixer drain valve and the drain channel using a hose. The hose may not be extended.	<input type="checkbox"/>
8.	Replace dummy plug and cable opening for Ethernet cable.	<input type="checkbox"/>
9.	Remove locks of antenna connections and connect antenna cable.	<input type="checkbox"/>
10.	Connect power plug to installed socket and turn on automatic feeder.	<input type="checkbox"/>
11.	Acknowledge the message Fault boiler not filled by pressing <input type="button" value="Enter"/> on the hand terminal.	<input type="checkbox"/>
12.	Confirm the message Fill boiler in the hand terminal with <input type="button" value="Enter"/> .	<input type="checkbox"/>
13.	Enter the time and date on the hand terminal using  Device data > Date and time.	<input type="checkbox"/>
14.	Run cleaning programs.	<input type="checkbox"/>
15.	Fill milk powder (MP).	<input type="checkbox"/>
16.	Perform calibration.	<input type="checkbox"/>
17.	Check setup settings.	<input type="checkbox"/>

9.2 Automatic feeder material list

The materials used in the automatic feeder include:

- Brass, Enzidor®
- Silicon carbide
- Carbon
- V2A, V4A
- Plastics: PET, TPE, silicone, PVC, NBR, ABS, PUR
- Viton
- Vulcanized fiber, graphitized
- Rubber
- Bronze

9.3 Automatic feeder shutdown checklist

Shutdown	OK?
1. Run cleaning cycle.	<input type="checkbox"/>
2. Drain water from boiler, solenoid valves, pressure valve, and volume control valve. <ul style="list-style-type: none"> 2.1 Close water tap. 2.2 With the hand terminal, via  > Boiler water > Start? dispense water into the mixer jar. 2.3 Disconnect water hose between water solenoid valve and boiler. 2.4 Open vent screw on boiler cover and drain boiler. 2.5 Reattach water hose and tighten vent screw. 	<input type="checkbox"/>
3. Turn off automatic feeder and disconnect power plug.	<input type="checkbox"/>
4. Disconnect and dispose of water hose.	<input type="checkbox"/>
5. Tip out liquid in mixer.	<input type="checkbox"/>
6. Disconnect hose between teat and feed station valve or mixer. Replace hoses and teats.	<input type="checkbox"/>
7. Disconnect hose between mixer drain valve and drain channel.	<input type="checkbox"/>
8. Close cable glands of antennas and Ethernet connection with dummy plugs.	<input type="checkbox"/>
9. Close cable glands of Ethernet Connection with dummy plugs.	<input type="checkbox"/>
10. Close antenna connection with locks.	<input type="checkbox"/>
11. Empty milk powder container.	<input type="checkbox"/>
12.  Empty detergent tank.	<input type="checkbox"/>
13. Remove powder container safety grid.	<input type="checkbox"/>
14. Basic cleaning of milk powder container and dosing unit.	<input type="checkbox"/>
15. Clean outside of automatic feeder with damp cloth.	<input type="checkbox"/>
16. Store the devices in a frost-free location, if possible.	<input type="checkbox"/>

9.4 Standard feeding plans

Standard Feeding Plan Group A

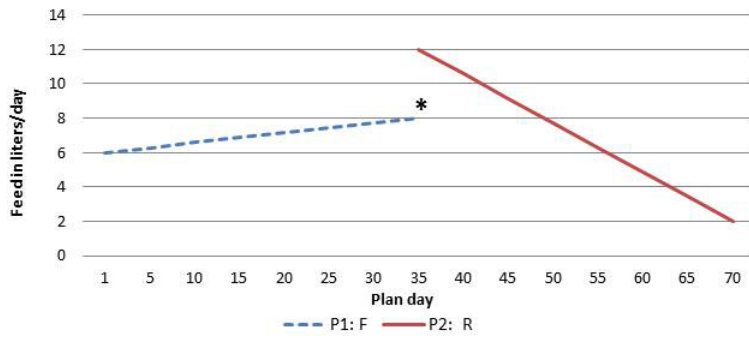

* This quantity is not intended as a maximum quantity but as a reference value to calculate an alarm level.

Standard Feeding Plan

P1: 35 days from 6 to 8 L *F*
 P2: 35 days from 12 to 2 L *R*

Total: 70 days

Standard Concentration Plan

P1: 70 days from 150 to 150 g/L

Standard Quantity Limitation Plan

P1: 10 days: 1.5 L (Min) 2.0 L (Max)
 P2: 25 days: 2.0 L (Min) 2.5 L (Max)
 P3: 35 days: 2.0 L (Min) 3.0 L (Max)

F = 40FIT feeding

R = Restricted feeding

Standard Feeding Plan Group B

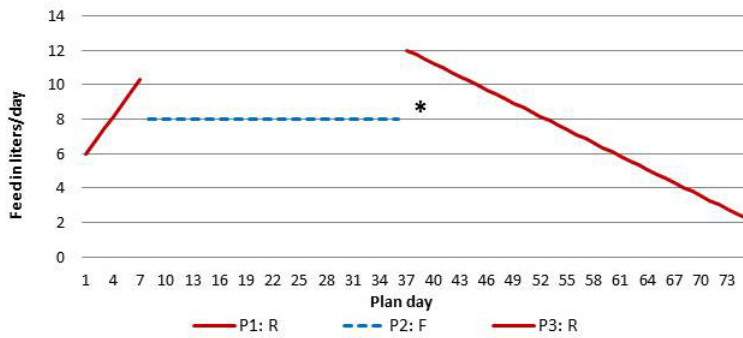

* This quantity is not intended as a maximum quantity but as a reference value to calculate an alarm level.

Standard Feeding Plan

P1: 7 days from 6 to 10 L *R*
 P2: 28 days from 8 to 8 L *F*
 P3: 40 days from 12 to 2 L *R*

Total: 75 days

Standard Concentration Plan

P1: 75 days from 150 to 150 g/L

Standard Quantity Limitation Plan

P1: 10 days: 1.5 L (Min) 2.0 L (Max)
 P2: 25 days: 2.0 L (Min) 2.5 L (Max)
 P3: 40 days: 2.0 L (Min) 3.0 L (Max)

F = 40FIT feeding

R = Restricted feeding

Standard Feeding Plan Group C

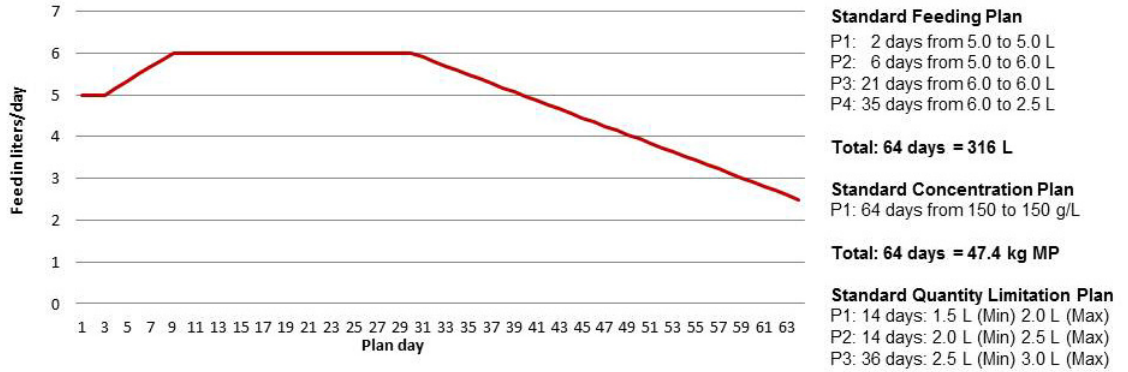

Standard Feeding Plan Group D

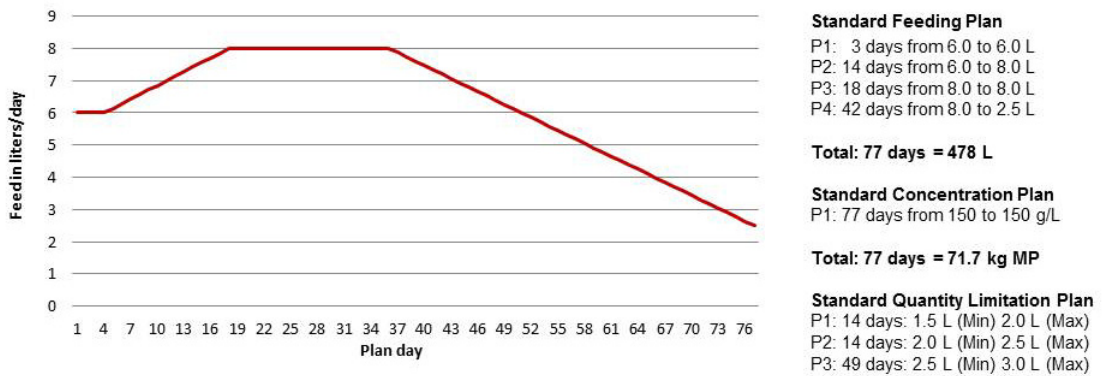

9.5 CAN bus addresses

Standard addresses

The following chart shows an example of address assignment based on default values. On the following page, you can assign completely customized addresses. Copy the template if needed.

Note: You can assign a number only once.

Note: If possible, do not change the standard addresses.

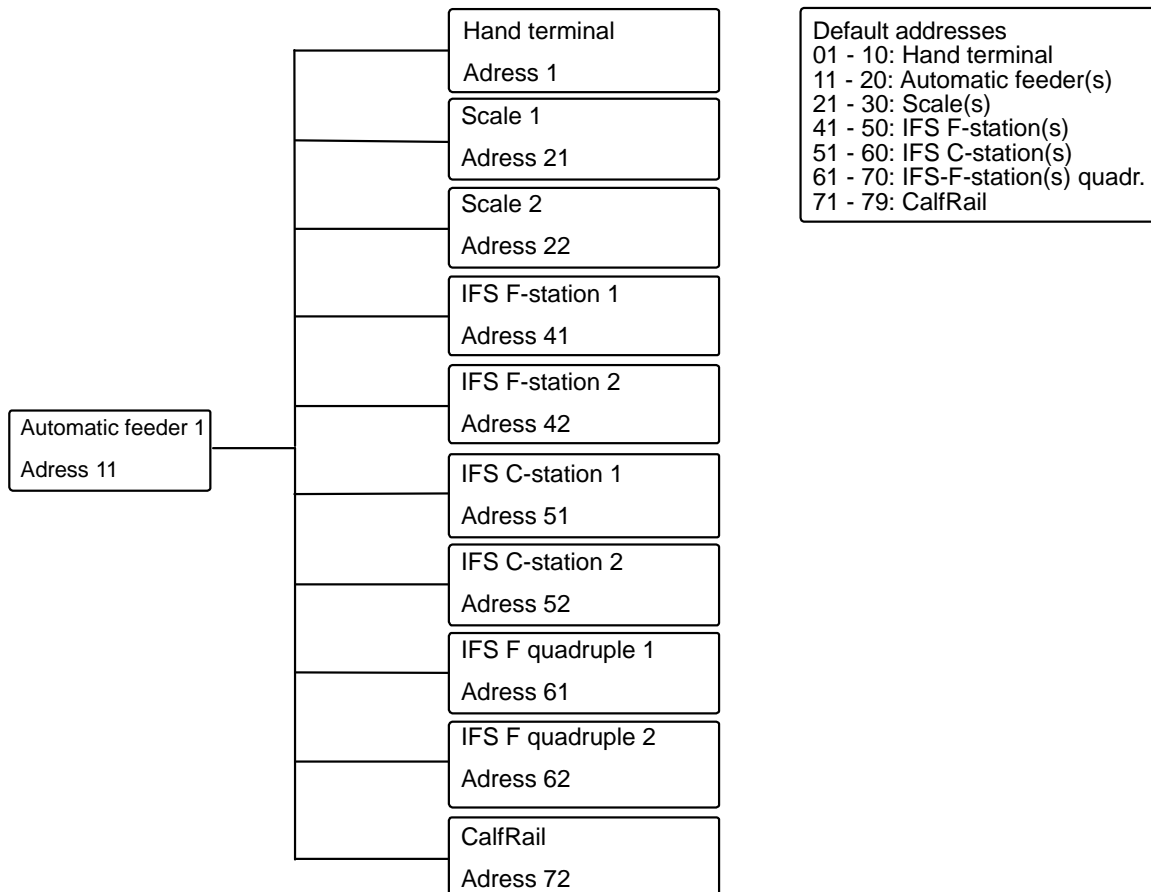

Template for custom address assignment

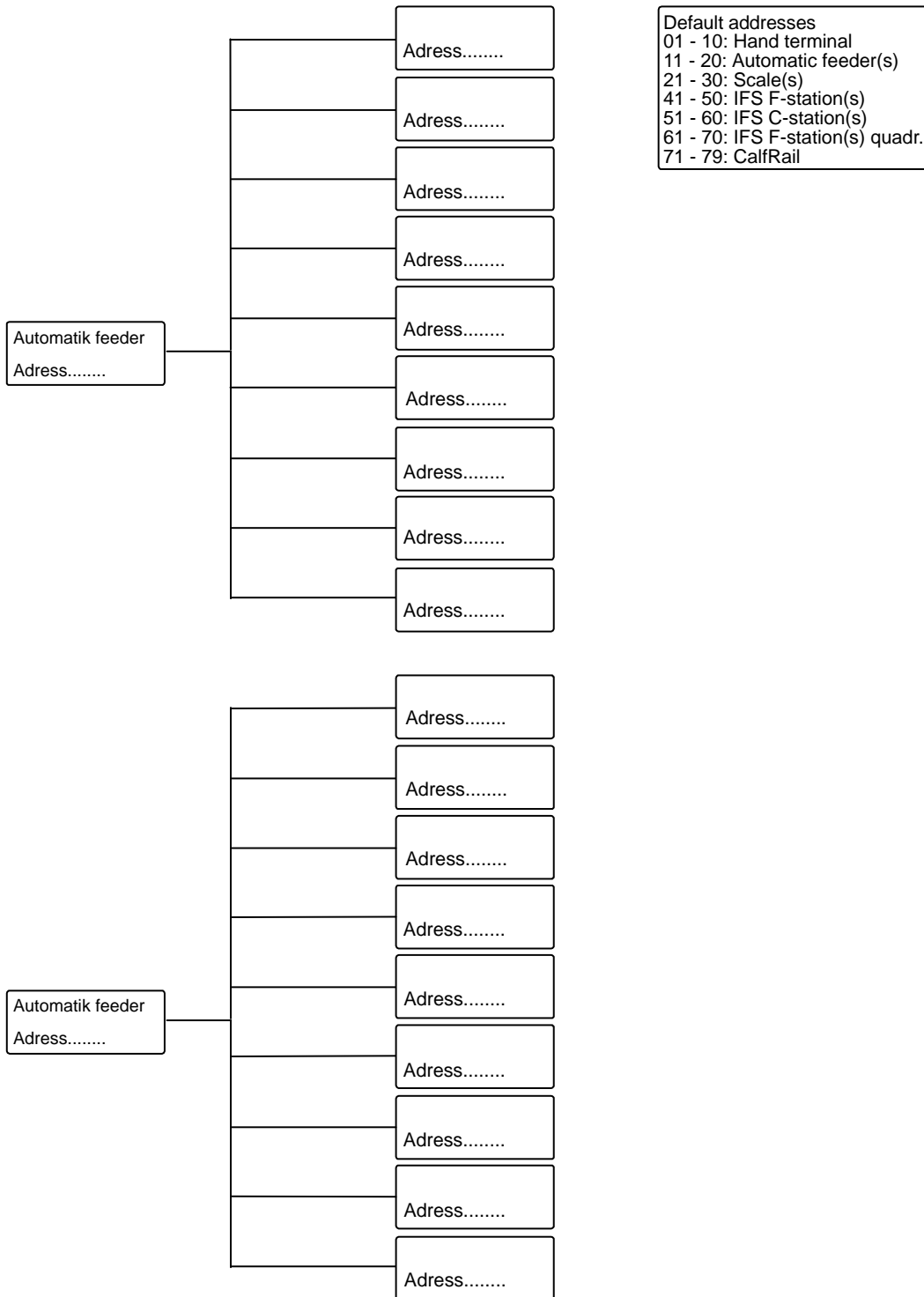

9.6 Measuring the components using test equipment in accordance with national regulations

All electrical components must be checked regularly for electrical safety in accordance with the intervals and test methods defined in the national regulations.

If any faults or damage are detected during the inspection, the faulty components have to be replaced before the automatic feeder can be used again.

A

Abbreviations 15
Additive dispenser 76
Alarms 53
Animal control 54
Animal list 40, 49, 62
Assigning animal numbers 85
Auto LED 50
automatic feeder components 14
Automatic feeder overview 8
Automatic feeder versions 7
Automatic mode 51

B

Base size 75

C

CalfCloud 68
Calibrating 40
 Automatic calibration 45
 Manually calibrating 40
Calibrating using the calibration scale 42
Calibrating without a calibration scale 40
Calibration scale 78
CAN analyzer 81
CAN bus 75
Cancel 90
 Group 91
Changing the animal number 86
Changing the transmitter number 86
Circulation valve 77
Cloud 68
Commissioning
 Connecting antennas 30
 Connecting Ethernet cables 33
 Filling the boiler 37
 Filling the powder container 36
 Installing feeding stations 29
 Installing stand partition 30
 Installing the safety grid 35
 Reconfiguring everything 37
 Setting offline mode 38
 Setting portion 38
 Squelch values and identification ranges 31
 Switching on the automatic feeder 37
Component check 40
Control 122

D

Data backup 65
 to Cloud 66
 With SD card 65

Deleting transmitter numbers 87
Detergent lance 37
Detergent pump 76
detergent supply line 36
Device data 56
Diagnosis 119
 Heating 120
 Motors 120
 Sensors 120
 Stations 121
 Valves 119
 Version 123
Disposal 14
Drain time station parameters 39

E

Electrical connection 12, 28

F

Faults
 Boiler not filled 103
 Boiler temperature sensor 106
 Box/drain valve 107
 Calibration 107
 Calibration scale 101
 Heating 102, 105
 Mixer emptying 104
 Temperature too high 102
 Water shortage 103
Front and right side view of the automatic feeder 8
Frost protection 27, 35

G

Grounding 28

H

Hand terminal 48
Hazard level
 Attention 20
 Caution 20
 Danger 20
 Warning 20
Hazards
 Chemical burns 19
 Corrosion 19
 Electrical breakdown 18
 Excessive strain 19
 Infection 19
 loss of stability 19
 Poisoning 18
 Short circuit 18
heater 77
Heating 76

I

Identification 32
Identification range 32
Important safety information 17
Instruction notices 21
Intended use 17

K

Keypad 49

L

Language 73

M

Managing transmitters 83
Manual functions 49, 56
Marking 53
Material damage 19
Measuring the components using test equipment 136
Mixer drain 76
Mixer temperature sensor 77

N

name plate 10
Navigation 53
Number of feeding stations and animals 14

O

Offline mode 50
Operating modes
 Ad lib mode 57
 Rationed mode 57

P

Permanent shutdown 96
Plan tendency 53
Portion 56, 58
portion 61
Prohibition notices 21

Q

Qualifications 17

R

Rear view of the automatic feeder 11
Recommissioning 96
Register 88

Registering

 Automatic 89
 automatic 88
 Manual 88

Reset 37

Residual current device 28

Residual risk 17

S**Safety devices**

 Safety grid for powder hopper attachment 24
 Safety temperature limiter 23
 Scraper 24

Safety labels 21

SD card 65

Service messages 117

Service technician 17

Service work 118

Setting up the automatic feeder 27

Setup 71

Shutdown 93

Sleep mode 53

Standard feeding plans 132

Symbols 14, 52

T

Technical data 12

Temporary shutdown 93

Time/date 73

Transferring 91

Transmitter 83

 Creating transmitter number 84
 Deleting the transmitter number 87
 Editing transmitter or animal numbers 86
 Retrieving transmitter statistics 87

V

vapor barrier 35

W

Warning signs 21

Warnings

 Address used twice 111
 Calibration 112
 Calibration scale 113
 Check SD card 115
 Double animal number 113
 Identification 111
 Incorrect ID 111
 Machine capacity 114
 Mixer emptying 109
 Mixer temperature sensor 110
 Unknown transmitters 112

Water connection 28

Water pressure 29

EC declaration of conformity

according to the EU Machinery Directive 2006/42/EG, Annex II, 1.A

Manufacturer:

Förster-Technik GmbH,
Gerwigstr. 25
78234 Engen

Person residing within the Community authorised to compile the relevant technical documentation:

Müller Barbara
Förster-Technik GmbH,
Gerwigstr. 25
78234 Engen

Description and identification of the machinery:

Make: Automatic feeder

Type: TAK5- VS1-*, TAP5-VS1-*, VDW5-VS1-*, TAK5-CS1-*, TAP5-CS1-*, VDW5-CS1-*, TAK5- VH2-*, TAP5-VH2-*, VDW5-VH2-*, TAK5-CH2-*, TAP5-CH2-*, VDW5-CH2-*, TAK1-KU2-*, TAK5-KR3-*, TAP1-ZM2-*, TAP2-ZM2-*, VDW1-WA2-*, TAP7-AH2-*

Function: Automatic preparation, heating, and dosing of liquid feeds for young animal feeding

It is expressly declared that the machinery fulfils all relevant provisions of the following EU Directives:

2006/42/EG Directive 2006/42/EG of the European Parliament and of the Council of 17 May 2006 on machinery, and amending Directive 95/16/EG (recast)

2014/30/EU Directive 2014/30/EU of the European Parliament and of the Council of 26 February 2014 on the harmonisation of the laws of the Member States relating to electromagnetic compatibility (recast)

97/23/EG (Pressure equipment) Directive 97/23/EG on the approximation of the laws of the Member States concerning pressure equipment

Reference to the harmonised standards used, as referred to in Article 7(2):

EN ISO 12100:2010-11 Safety of machinery - Electrical equipment of machines - Part 1: General requirements (ISO 12100:2010)

EN 60335-1:2012/A11:2014 Household and similar electrical appliances - Safety - Part 1: General requirements IEC 60335-1:2010 (modified)

EN 61000-6-2:2005/AC:2005 Electromagnetic compatibility (EMC) - Part 6-2: Generic standards - Immunity for industrial environments

EN 61000-6-3:2007/A1:2011/AC:2012 Electromagnetic compatibility (EMC) - Part 6-3: Generic standards - Emission standard for residential, commercial and light-industrial environments

Engen, 20.04.2016



Place, date

Signature
Markus Förster
CEO