

July 2002

Instruction Book System-Machine Powder

As of Program Version 01.01

TAP5-SM2-27-F1

TAP5-SM2-28-P1

TAP5-SM2-30-P1



1	Introduction	5
1.1	Safety Instructions	5
1.2	Danger Signs on the Automatic Calf Feeder	6
1.3	Information Signs on the Automatic Calf Feeder	6
1.4	Construction Parts System-Machine Powder	7
1.4.1	Motherboard and Distribution Board SM 2 Plus	9
1.4.2	Water Heating in the Boiler	10
1.4.3	Hand-Actuated Feeding Pump	11
2	Specifications Automatic Calf Feeder	12
3	Locating the Automatic Calf Feeder	13
3.1	Local Electrical Connection	13
3.2	Installing the Automatic Calf Feeder	13
3.3	Mounting the Sucking Station	14
3.4	Mounting the Race-Way and Connecting the Identification	15
3.5	Water Connection	16
4	Operating Elements	17
4.1	Keyboard	17
4.1.1	Operational Control Keys	18
4.1.2	Entering the Values	19
4.1.3	Selecting the Options	20
5	Installing the Automatic Calf Feeder	21
5.1	Checking the Jumper in case of Relay Interface	21
5.2	Connecting the Automatic Calf Feeder to the Mains Supply	21
5.3	Filling the Boiler with Water	21
5.4	Filling the Milk Powder into the Powder Hopper	22
5.5	Calibrating the Feed Components	22
5.6	Setting the Heating	23
5.6.1	Adjusting the Thermostats	23
5.6.2	Recommendations for Temperature Settings	24
5.6.3	Measuring the Temperature	24
5.7	Heating for Milk Powder Outlet and Protection against Frost	25
6	Functioning of the Automatic Calf Feeder	26
6.1	Preparing the Milk Portions	26
6.2	Distributing the Milk	26
6.2.1	In the Restricted Mode	26
6.2.2	In the Ad Libitum Mode	26
7	Settings in Setup	27
7.1	Different selections in Setup	27
7.2	Function Table „Setup“	29
7.3	How to make entries in Setup	30
7.4	Connecting the System-Machine to the Feeding Computer	31
8	Functions of the Menu Key	33
8.1	Hand Functions	33
8.2	Portion Values	34
8.2.1	Selecting the Concentration	34
8.2.2	Entering the Additive	34

8.2.3	Restricted/Adlib-Mode	35
8.3	Calibration	35
8.3.1	Calibrating Water and MP (milk powder)	35
8.3.2	Calibrating Additives and Detergent	37
8.4	Machine Values	37
8.4.1	Intermediate Mix	37
8.4.2	Mixer Afterrun	37
8.4.3	Emptying Mixer	38
8.4.4	Entering the Distribution Pause	38
8.4.5	Box 1 / Box 2	38
8.5	Diagnosis	39
8.5.1	Valves/Motors	39
8.5.2	Sensors	39
8.5.3	Calibration	40
8.5.4	Interface	40
8.5.5	Checking	40
8.6	Version	41
8.7	Function Table of the Menu-Key for Connection to Feeding Computer	42
9	Functions of the Automatic Key	44
9.1	Display in the Automatic-Mode	44
9.2	Releasing an Extra-Portion	45
10	Functions of the Cleaning Key	47
10.1	Entering the Figures	48
10.2	Selecting the Options	49
10.3	Cleaning	50
10.3.1	Mixer Cleaning	50
10.3.2	Air Cleaning	51
10.4	Settings	52
10.4.1	Mixer Cleaning	52
10.4.2	Air Cleaning	52
10.4.3	Detergent	52
11	Service and Maintenance of the Automatic Calf Feeder	53
11.1	The Day after the First Commissioning	53
11.2	Carrying Out a Regular Check Routine	53
11.3	Shutdown	54
12	Fault Messages	55
12.1	Memory Error	55
12.2	Temperature	55
12.3	Electrode Fault	55
12.4	Lack of Water	55
12.5	Emptying Mixer	56
13	Accessories	57
13.1	Two-Group-Valve-Unit	57
13.2	Additive Dispenser	58
13.3	Electrical Vapour Screen for MP- and Powder Additive Outlet	58
13.4	Detergent Dosing Pump	59
13.5	Protection against Flies	59
14	Replacement of the Program Chip	60
	EC DECLARATION OF CONFORMITY	A

1 Introduction

1.1 Safety Instructions

Be sure to read and follow all instructions contained in this manual before connecting and using the automatic calf feeder.

- Use the appliance only to feed calves.
- Servicing and installation of the automatic calf feeder has to be restricted to qualified and authorised service personnel.
- Read the user's manual carefully before installing or operating the machine.
To facilitate customer service on the calf feeders, store the documentation accompanying the appliance near to the automatic feeder.
- The faultless functioning of the automatic calf feeder requires expert installation, correct handling, as well as careful care and maintenance.
- Incorrect data entries may have serious consequences. Therefore check the correctness of all data entries.
- The livestock owner is responsible for a regular and scrupulous control of his animals and the functioning of the appliance. If, for any reason, the system should break down or some calves should not make use of it, the livestock owner is responsible for choosing other feeding methods for those animals.
- The manufacturer accepts no responsibility for damages and their consequences caused by incorrect installation and operation, improper use, inadequate service and maintenance or false entries.
- Remove any projecting object from the stable (e.g. pipe ends), because Responder collars could get caught in it.
- You will find further safety instructions in the following chapters.

1.2 Danger Signs on the Automatic Calf Feeder



CAUTION!

This sign warns you of **rotating parts starting to work automatically**.

This sign is located on potential danger areas such as the milk powder hopper, the milk powder outlet, the mixer as well as the outlet for powder additives on the additive dispenser.

In order to avoid injuries, **before** carrying out any kind of operation on above listed parts, it is imperative to make the automatic feeder currentless by turning the main switch to position „0/OFF“ or by pulling the mains plug.

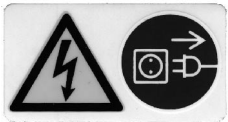

CAUTION!

This sign warns you of **electric shocks**.

In order to avoid injuries, **before** opening the control unit, it is imperative to make the automatic feeder currentless by turning the main switch to position „0/OFF“ or by pulling the mains plug.

1.3 Information Signs on the Automatic Calf Feeder



Before connecting the automatic calf feeder to the mains supply and activating the heating (see chapter 5 “Installing the Automatic Calf Feeder”, page 21), **carefully read the operating instructions**.

Any questions about this product? Then, feel free to get in touch with us. Before calling us, please write down the information (machine type, machine number) on the nameplate located at the left of the feeder chassis, as well as the program version (refer to chapter „Menu 1-99, Machine data“).

Our address:

Förster-Technik GmbH,

Gerwigstr. 25,

D-78234 Engen,

Tel. +49/(0)7733/9406-0,

Fax +49/(0)7733/9406-99

Internet: www.foerster-technik.de

1.4 Construction Parts System-Machine Powder

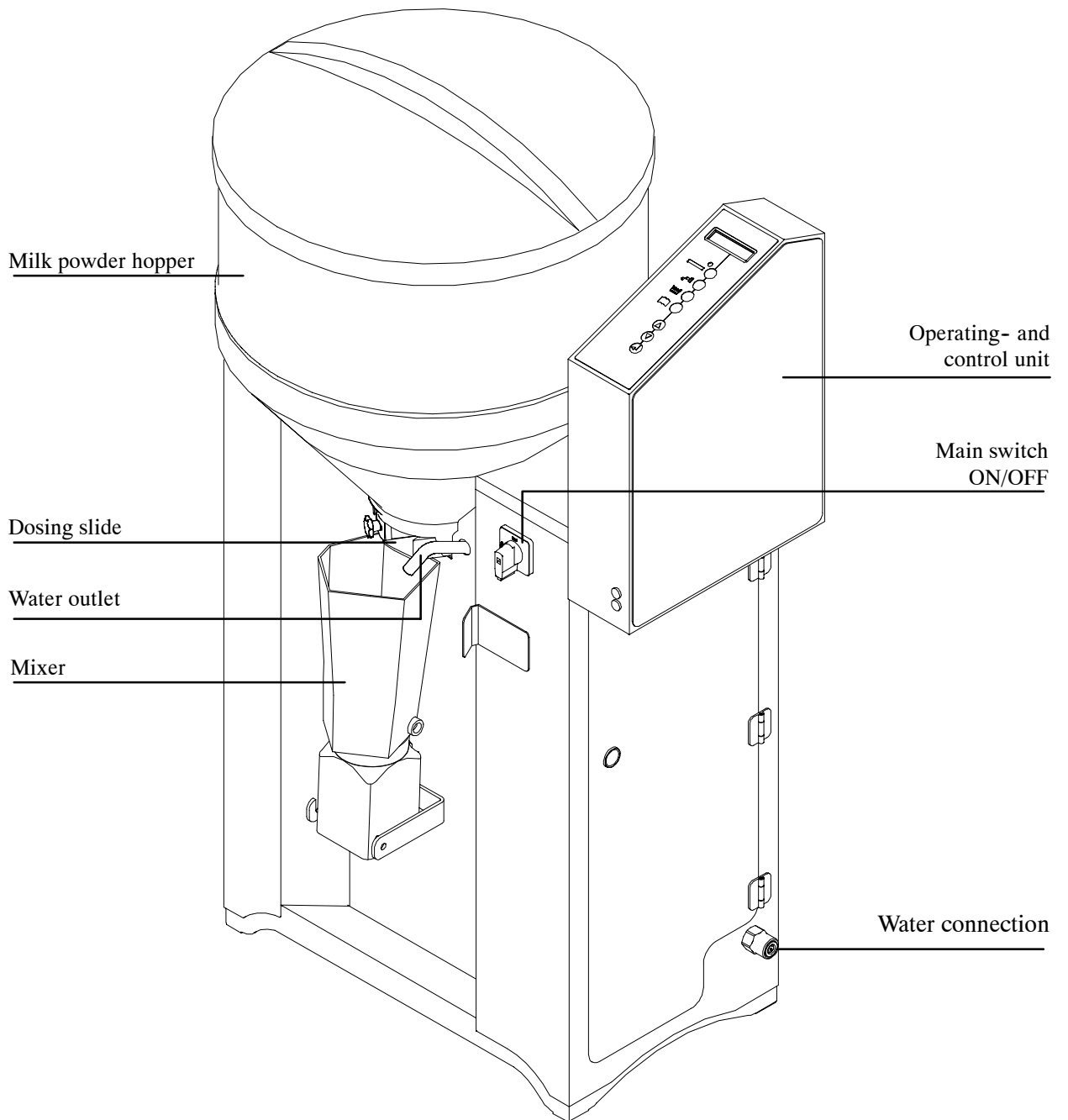

Heating thermostat

Thermostat for minimum operating temperature



Water valve boiler

Water connection

Water connection for hose cleaning

Detergent pump (accessory)

Box valve 1

Box valve 2 (accessory)

Receptacle for detergent (accessory)

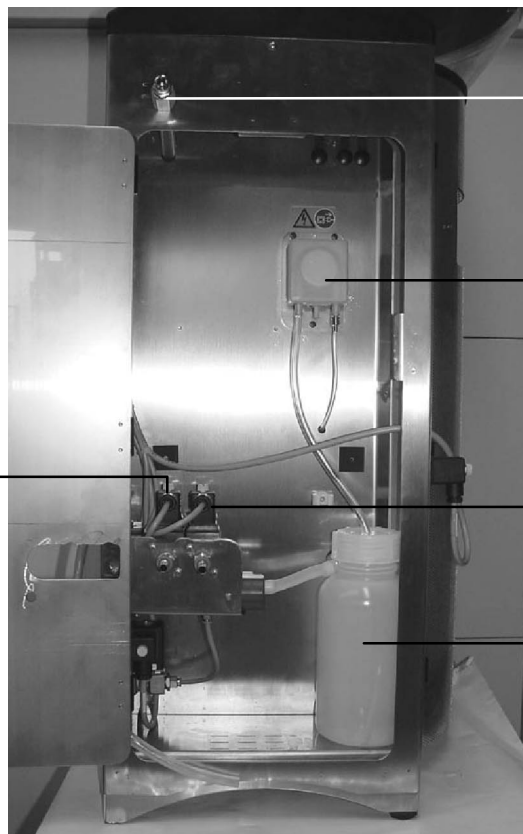

1.4.1 Motherboard and Distribution Board SM 2 Plus

On the motherboard are located the transformer for weak current supply of the processor control, the relays, the connectors for external components, the fuses and LEDs.

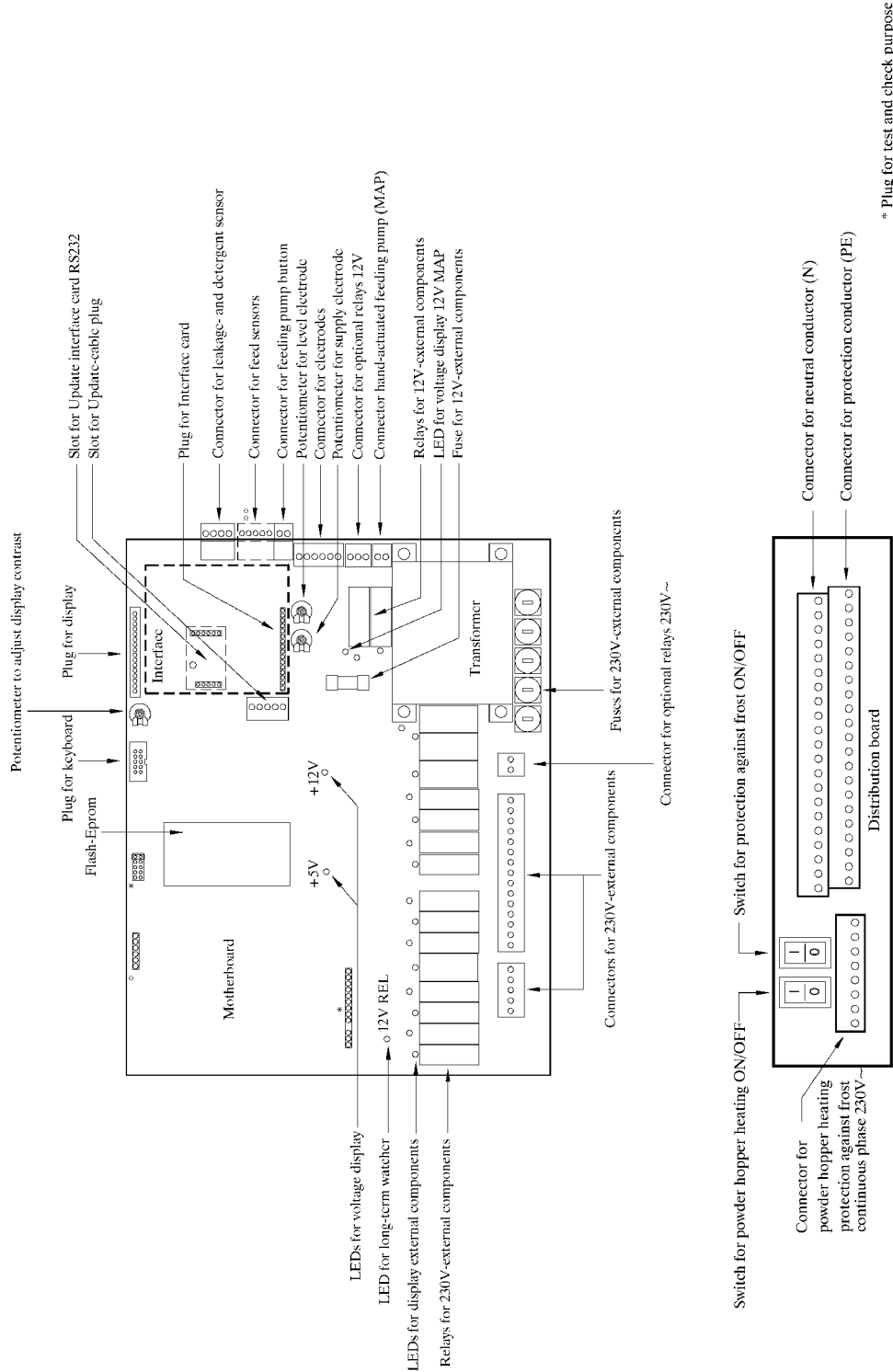

* Plug for test and check purpose
** depending on the model

1.4.2 Water Heating in the Boiler

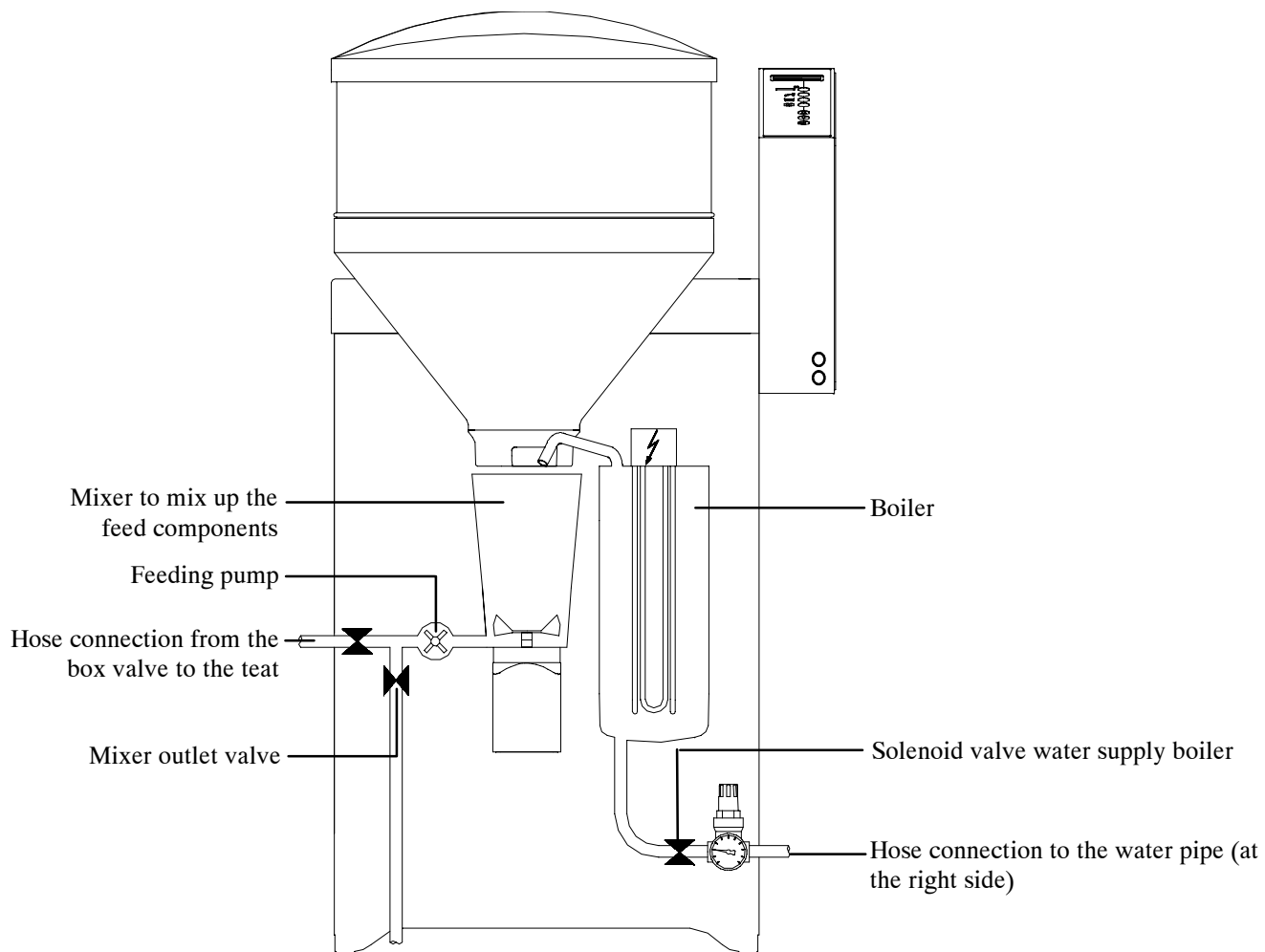

1.4.3 Hand-Actuated Feeding Pump

Thanks to the hand-actuated feeding pump that is located below the valve unit, calves may easily get accustomed to the teat. You can activate the feeding pump either by pressing a key on the operating unit (stylized teat) or by pushing a button on the remote control. The milk is then delivered directly from the mixer via the valve unit to the teat and into the mouth of the calf.

You can also use the feeding pump e.g. to drain off manually the rinsing water in the mixer jar via the mixer outlet valve. To this end, press Menu key and select „Emptying Mixer“ in submenu „Hand Functions“.

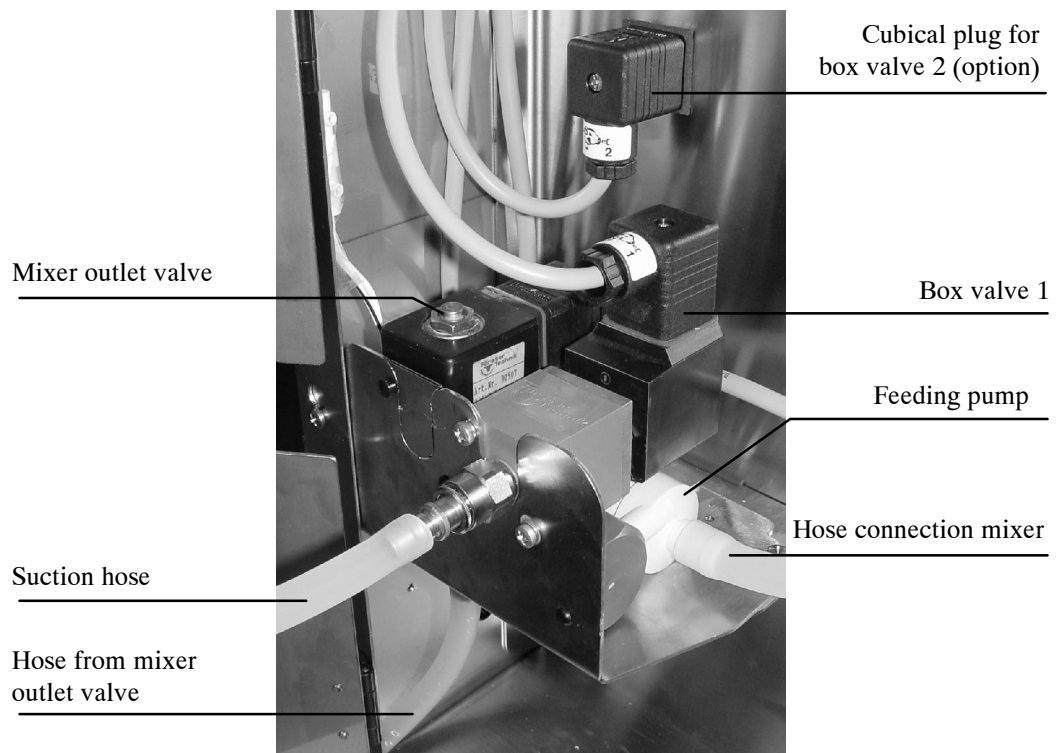

Do not clean the feeding pump by means of the cleaning sponge!

2 Specifications Automatic Calf Feeder

Please observe the information on the nameplate located at the left of the chassis!

Electrical connection

TAP5-SM2-27-F1 (400V)

230V / 400V / 3 / N / PE / 50 Hz / 16 A

TAP5-SM2-27-F1 (230V)

230V / L / N / PE / 50 Hz / 16 A

TAP5-SM2-28-P1 (only for U.S.A and Canada)

240V / L1, L2 / Grd / 60 Hz, 15 A

TAP5-SM2-30-P1 (only for Japan)

200V / 50/60 Hz, 20 A

Dimensions of the calf feeder

Height: 126 cm

Width: 67 cm in case of closed lateral door
115 cm in case of open lateral doors

Depth: 57 cm without dispenser for powder additives
66 cm with dispenser for powder additives

Weight (with basic equipment): approx. 60 kg

Water connection

1/2" hose with 3/4" hose coupling.

The local water pressure has to be between 2,5 and 6 bar.

Boiler

Capacity: approx. 7 l

Milk powder hopper - storage capacity (with top section)

approx. 35 kg

Number of animals per sucking station

Each calf feeder can provide approx. 20 - 30 rearing calves or 15 - 20 fattening calves per sucking station with feed. One calf feeder with two sucking stations can provide approx. 50 - 60 rearing calves, 20 - 30 fattening calves or 20 rearing calves and 15 fattening calves with feed.

Specifications are subject to change without prior notice.

3 Locating the Automatic Calf Feeder

3.1 Local Electrical Connection

- Refer installation of the local electrical connection to qualified electricians.
- Observe local recommendations and protective measures. To operate the automatic calf feeder, it is demanded to install an earth leak switch (30 mA) in the local power supply.
- The automatic calf feeder requires its own power supply: *refer to chapter 2, page 12, „Specifications“*.
- Observe rated voltage and frequency. The rated voltage indicated on the nameplate of the calf feeder must correspond to the one of the mains supply.
- In case of overvoltage risk, install an overvoltage limiter in the local main distribution frame.

Earth bonding For animals' safety and to prevent electrical interferences, carry out an earth bonding of all metal parts such as water pipe, sucking station, race-way and automatic calf feeder. At the rear of the calf feeder is located the connection screw for the earth bonding which has to be connected to earth, such as e.g. an equipotential busbar, by means of a short coupling.

Lightning protection As it is technically impossible to protect the installation against lightning stroke separately, it is to the owner to install an adequate lightning protection, such as e.g. a lightning protection system for the entire building. We recommend to conclude a lightning protection insurance.

3.2 Installing the Automatic Calf Feeder

- It is advisable to place the calf feeder in a dry location, if possible, not in the animal area (e.g. in the fodder storage or similar detached room).
- A fence of planks protects the automatic calf feeder against dirt and flies. In summer, when flies occur with increased frequency, you can protect the mixer jar, the milk powder and the additive outlet by means of a large fly protection (accessory). Steam can easily escape through the openings of the fly screen grating.
- Frost does not cause any damages to the automatic calf feeder. In order to ensure a good functioning of the feeding process even in case of frost, you have to equip the calf feeder with an equipment for protection against frost (accessory). The owner is responsible for a reliable water supply.
- The suction hoses can be easily guided through a wall.

3.3 Mounting the Sucking Station

- Install the sucking station max. 65 cm above the stable ground. Mount the teat approx. 15 cm above the suction hose connection of the mixer.
- Fix the suction hose in such a way, that the mixer jar can easily be tipped in forward direction. The suction hoses should not exceed a length of 2 m.
- Mount the suction bracket with splash board towards the bottom.
- Make sure that there is no sag in the connecting hose between mixer and feeding pump, in order to prevent accumulation of water or milk.

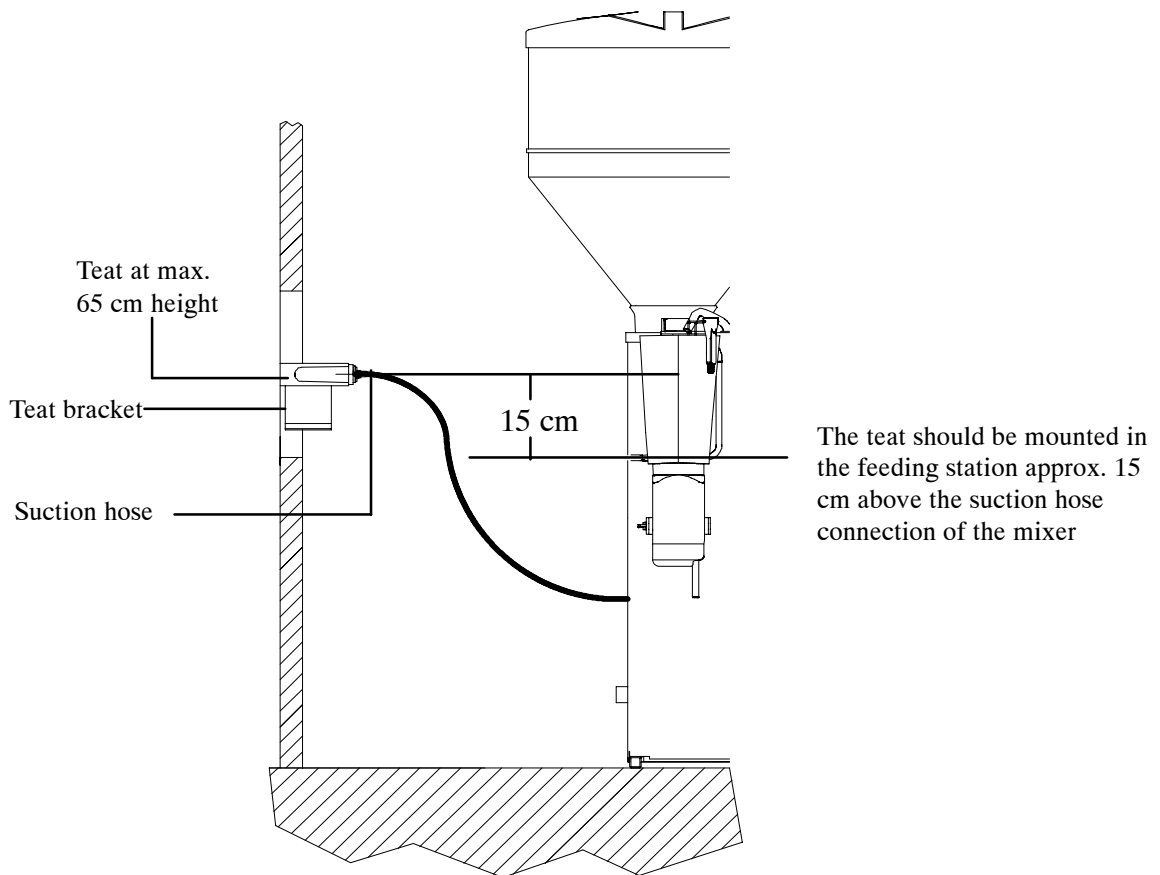

3.4 Mounting the Race-Way and Connecting the Identification

Mount an appropriate race-way in front of the sucking station, in order to prevent a calf from being pushed aside by other calves.

- Mount the race-way according to the mounting instructions.
- Connect the identification according to the mounting instructions.

Install the cable for the connection of the identification in such a way that the calves cannot touch it.

3.5 Water Connection

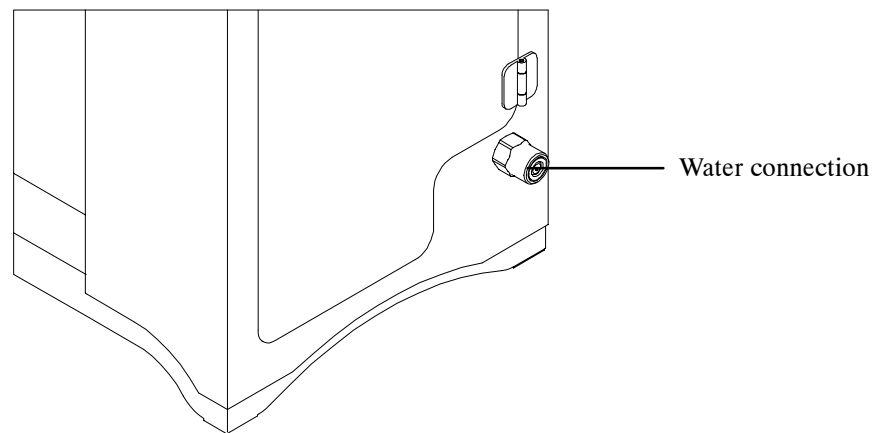

- Connect the 1/2" water hose with a 3/4" hose coupling at the right of the automatic calf feeder.

The water pressure supplied by customer has to be between 2,5 and 6 bar.

Note: To ensure troublefree functioning of the automatic feeder, take care that the water pressure does not fall below 2,5 bar!

Take care that there is no pressure variation of the water pipe.

In case of water pipes with small cross section it may happen that, in the feeding mode or when water is taken out of the same pipe simultaneously, the water pressure will drop.

When the water pressure is below 2,5 bar you have to use a header tank.

Install additional water stop valve.

Since September 1, 2000 the pressure reducer is factory-set to 1,5 bar.

Do not alter the setting of the pressure reducer!

In case the notes above should not be observed, there is no guarantee that the automatic feeder will run trouble-free!

4 Operating Elements

4.1 Keyboard

You can carry out all major settings and operations concerning e.g. operating mode, portion values, calibration, cleaning, diagnosis etc. via the keyboard. The display shows all current settings.

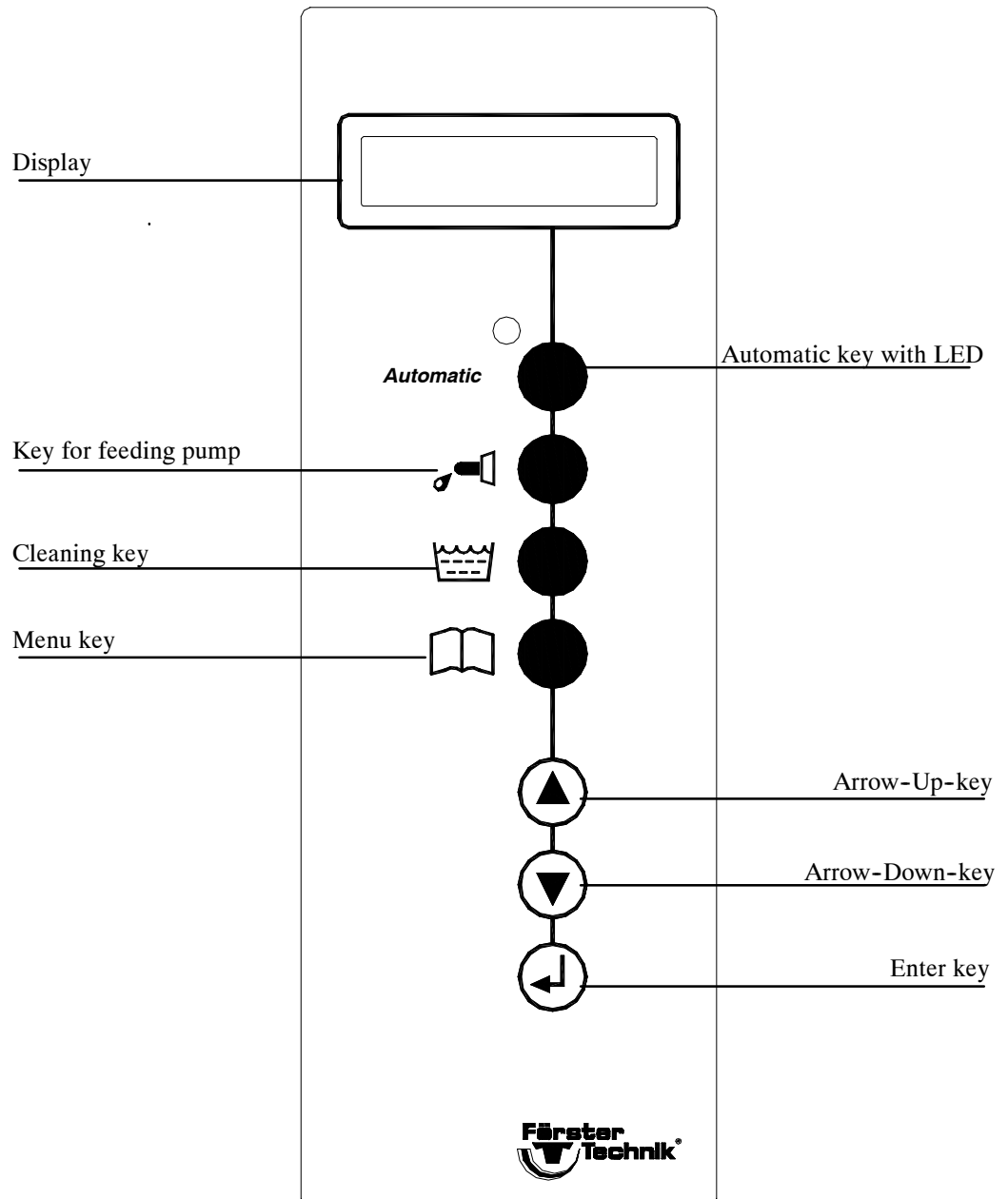

4.1.1 Operational Control Keys

Automatic

Automatic key: the automatic calf feeder runs in the automatic mode. You will find more detailed information on the individual functions in chapter 9, page 44 ff.



Press this key to activate the feeding pump.



Press Cleaning key to access the cleaning menu. You will find more detailed information on the individual functions in chapter 10, page 47 ff.



Press Menu key to select several functions resp. main menus. For more detailed information, see chapter 8, page 33 ff.



Press Arrow Up/Arrow Down to move through the different menus and to change the settings.



Press Enter key to open the menus and store the settings.

4.1.2 Entering the Values

Press Arrow Up/Arrow Down or Enter to enter, set or change the values concerning e.g. calibration, concentration, additive amount etc. Press the Menu key to access the main menus. Press Enter to change a value. The value displayed on the screen starts flashing (e.g. >120<). Arrow Up is used to increase and Arrow Down to decrease the set value. The longer you keep the relevant Arrow key pressed the faster you can change the displayed value. Once you set the correct value, press Enter to store it (the value stops flashing). In case you do not wish to change the value, press the Menu key to return to the main menu.

Example for the input of values within the functions of the Menu key:

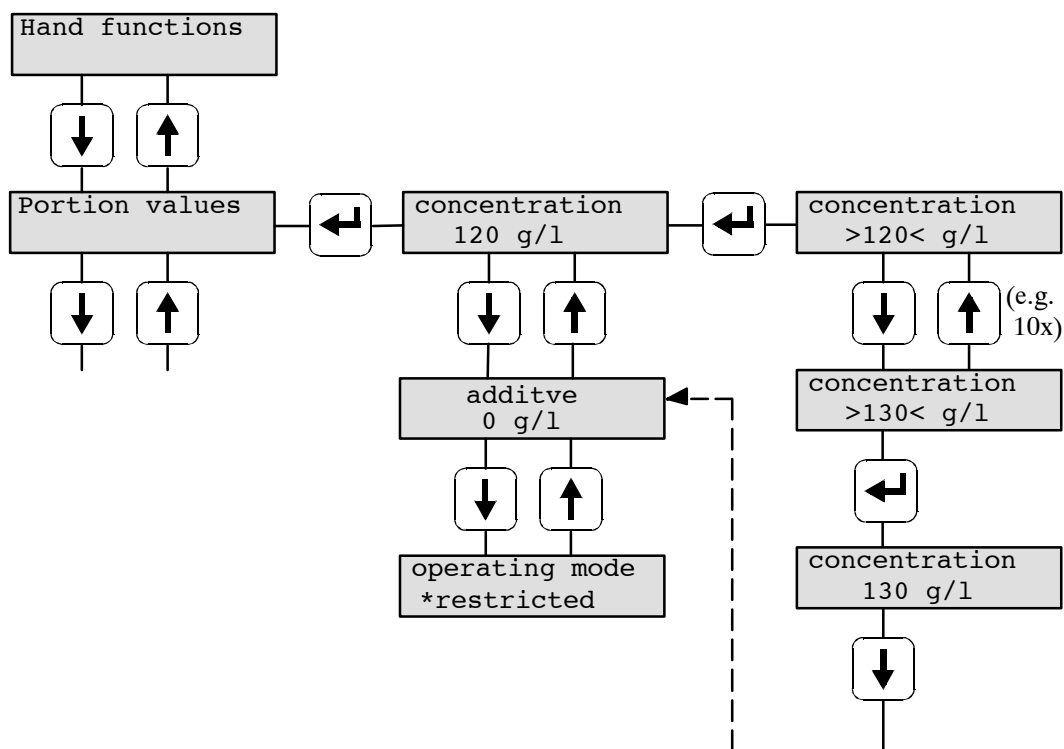

4.1.3 Selecting the Options

You can only select one of the available options. The automatic feeder can run either in the „ad libitum“ or in the „restricted“ mode. The selected option is marked by an asterisk in the second line of the display.

Press Enter to change the option. The selected option starts flashing. Press Arrow Up/Arrow Down to move to the available options. Press Enter as soon as the display shows the desired option. The option is then marked by an asterisk and subsequently stored. In case you do not wish to change the option, press the Menu key to return to the main menu.

Example for the input of values within the functions of the Menu key:

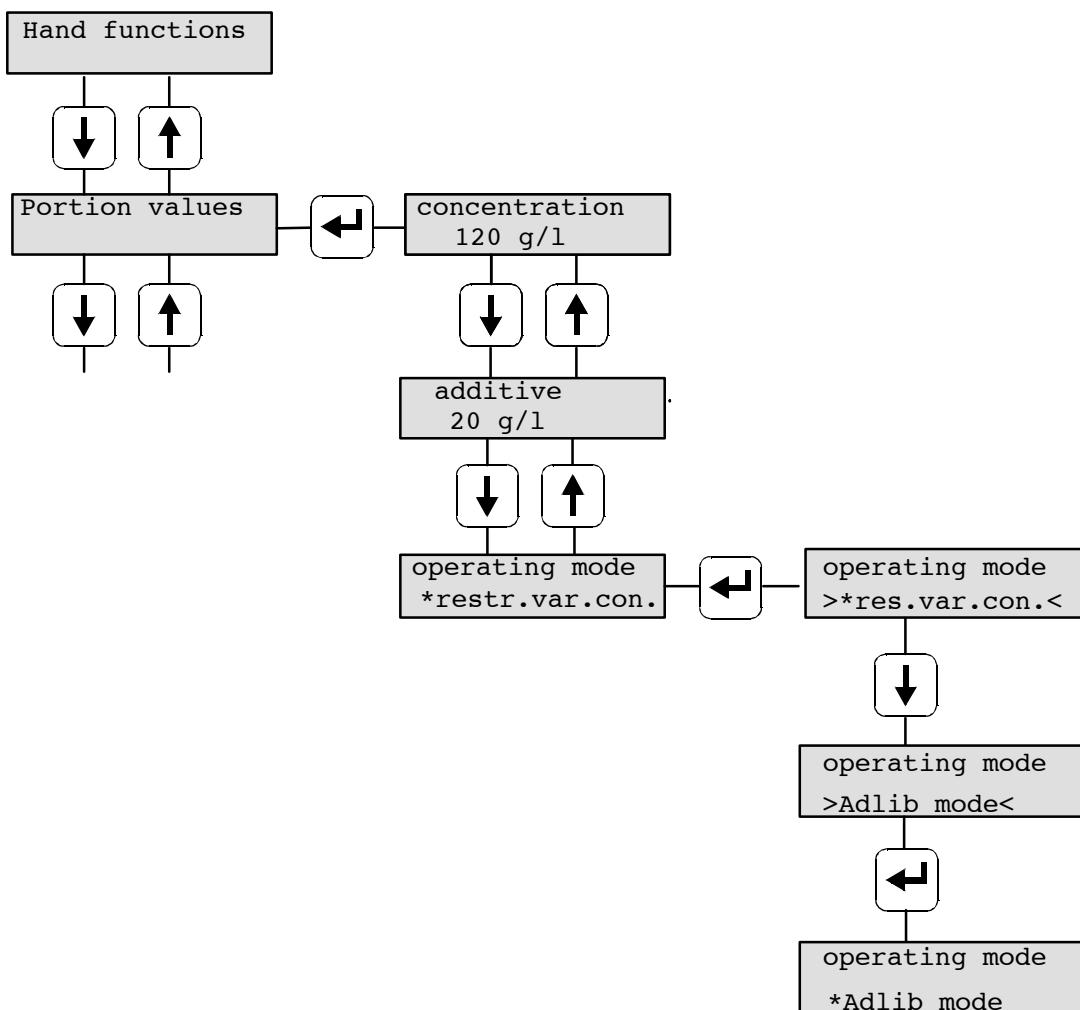

5 Installing the Automatic Calf Feeder

5.1 Checking the Jumper in case of Relay Interface

When the System-Machine is connected to a feeding computer with relay interface, during installation you have to take care that the jumper for signal empty is in the correct position. The jumper has already been factory-set. Check the position of the jumper only in case a calf with drinking right is staying in the feeding station and the automatic feeder does not prepare a drinking portion, even if the mixer jar is empty.



CAUTION! In order to avoid injuries due to electric shocks, **before** opening the control unit it is imperative to make the automatic feeder currentless by turning the program switch to position „0“/„OFF“ or by pulling the mains plug.

- Open the control unit and check the position of the jumper.

5.2 Connecting the Automatic Calf Feeder to the Mains Supply

Warning: Before switching the heating on, fill up the boiler, otherwise it will be damaged. There will be no guarantee for a reliable functioning of the automatic feeder.

- Open the door on the right-hand side of the chassis.
- Turn back both thermostats to zero.

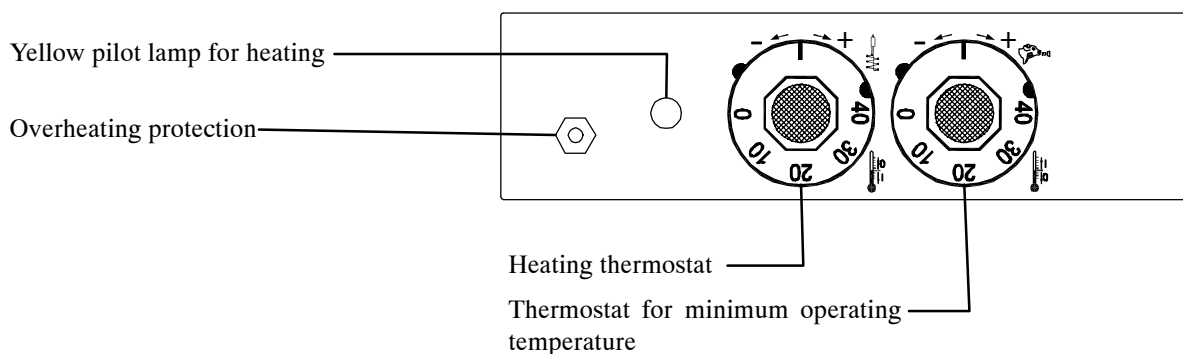

- Connect the mains plug and switch the automatic feeder on by turning the main switch to position „I“/„ON“. As soon as the display shows the program version, press the Menu-key and observe the instructions contained in chapter 5.3 „Filling the Boiler with Water“.

5.3 Filling the Boiler with Water

Press **Menu key**, go to submenu “**Hand Functions**” and select “**Boiler fill?**”. After two to three minutes some water will come out of the water outlet. Only then the filling process will be completed.

5.4 Filling the Milk Powder into the Powder Hopper



CAUTION! In order to avoid injuries due to **rotating parts (inside the powder hopper)**, **before** carrying out any kind of operation on the milk powder hopper, such as e.g. filling the milk powder into the powder hopper, it is imperative to make the automatic feeder currentless by turning the main switch to „0/OFF“ or by pulling the mains plug.

- Only fill in milk powder that is suitable for calf feeding. Do not put paper or other foreign matter into the powder hopper.

There is no warning in case the powder hopper should be empty! The automatic feeder continues working in the feeding mode without milk powder.

5.5 Calibrating the Feed Components

You have to calibrate all feed components otherwise the automatic feeder cannot prepare an exact feed mix in feeding mode.

Calibration is defined as the input into the computer of the amount of water and milk powder (MP) distributed during a fixed period of time.

In case the automatic feeder is additionally equipped with a detergent dosing pump or/and a dispenser for powder additives, it is imperative to calibrate both of them.

For more detailed information on calibration, see chapter 8.3, page 35, „Functions of the Menu key, Calibration“.

5.6 Setting the Heating

Switch the heating on only after you have filled the boiler with water!

Thermostat for minimum operating temperature and heating:

The thermostat for minimum operating temperature prevents too cold milk or water from being distributed. When the temperature in the boiler falls below the set minimum temperature of the water in the boiler, the preparation of the milk is interrupted until the minimum temperature is reached.

When the minimum operating temperature is not reached, the display shows the following message:

```
fault
temp. too low
```

Factory settings:

The minimum operating temperature is factory-set between 38°C and 39°C. The minimum operating temperature should always be set 3°C below the heating temperature, in order to avoid overlaps in the control range.

The heating temperature is factory-set between 42°C and 43°C.

The calibration menu helps you checking the water temperature.

For calibration, refer to chapter 8.3, page 35, „Functions of the Menu key, Calibration“!

5.6.1 Adjusting the Thermostats

- Open the door on the right-hand side of the chassis.
- Turn the thermostat for minimum operating temperature (green) so far clockwise, until both green marks coincide.

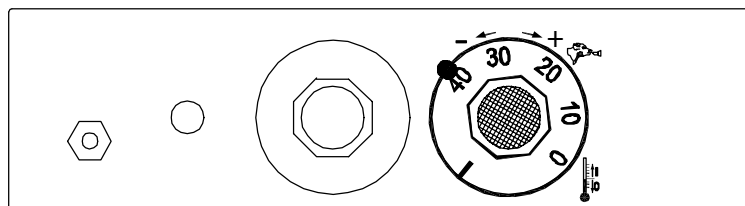

- Turn the thermostat for boiler heating (red) so far clockwise, until both red marks coincide.

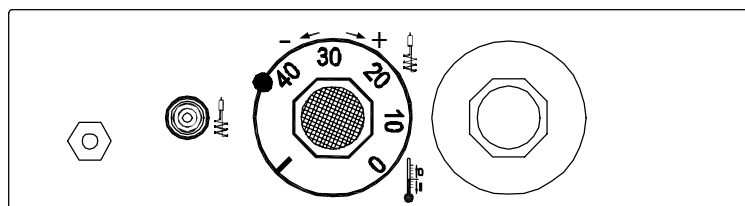

The marks facilitate temperature setting.
Yet, you have to check the settings regularly.

5.6.2 Recommendations for Temperature Settings

The boiler is designed in such a way that also the cheaper milk powders with higher fat melting point can be used without problems. In this case, the outlet temperature has to be exactly between 42°C and 43°C.

The temperature has to be set very carefully. When reducing the heating temperature don't forget to reduce the minimum operating temperature accordingly. Too low temperatures may cause indigestion whereas too high temperatures over a long period of time may lead to inflammation of the mucosa in the abomasum. Flatulence may indicate that the drinking temperature is too high.

5.6.3 Measuring the Temperature

The setting of the heating is related to the portion size and the drinking speed of the calves. To measure the temperature do not extract more than 0.5 l. In case of further measurements, wait until the boiler has restored the temperature. Heat transmission time depends on the input and outlet temperature of the liquid and may vary between 10 and 25 seconds.

To measure the temperature proceed as follows:

- Press Menu key.
- Press Arrow Down to move to menu „Calibration“.
- Press Enter to go to submenu „Water boiler, start“.
- Wait until the yellow pilot lamp of the boiler water heating has gone out.
- Hold a measuring vessel under the water outlet.
- Press Enter to start water distribution.
- Immediately afterwards, measure the temperature by means of a thermometer.

Wait for heat transfer time (approx. 30 seconds), prior to distribution of the next portion. After you have carried out careful measurement, correct the temperature, if necessary, until the desired temperature is reached. For further measurements, wait until the yellow pilot lamp for the heating has gone out.

5.7 Heating for Milk Powder Outlet and Protection against Frost

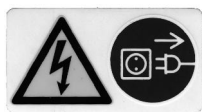

CAUTION! In order to avoid injuries due to electric shocks, **before** opening the control unit it is imperative to make the automatic feeder currentless by turning the main switch to position „0/OFF“ or by pulling the mains plug.

Inside the control unit is located a distribution board with integrated switches. The left switch is used for switching on and off the heating for the milk powder outlet. The right switch is used for switching the heating cable on and off.

In summer it is imperative to set both switches to „0“ (= OFF)!

The heating for the milk powder outlet prevents formation of condensate on the milk powder outlet.

The heating cable with temperature control is available as an accessory and can be retrofitted at any time. It is active when temperature falls below 3°C and protects hose pipes, solenoid valves and pressure reducer against frost. We recommend to mount a heating cable in case the calf feeder should be installed in an unprotected location exposed to extreme cold.

6 Functioning of the Automatic Calf Feeder

6.1 Preparing the Milk Portions

When the liquid jet hits the supply electrode located at the water outlet, a pre-set milk powder portion falls from the powder hopper into the mixer jar where it is mixed with the liquid.

The mixer is connected via a box valve to the sucking station by means of a suction hose. The milk runs through the suction hose to the teat in the sucking station.

You can interrupt the preparation of a feeding portion at any time by pressing the „Automatic“, „Cleaning“, „Menu“ or „Enter“ key.

6.2 Distributing the Milk

6.2.1 In the Restricted Mode

The rod electrode is free:

When an animal with drinking right enters the feeding box and is identified, the automatic calf feeder prepares a milk portion as soon as the mixer jar is empty. The milk in the mixer jar grounds the rod electrode. When the calf has drunk the milk, the rod electrode is free again and the machine starts preparing the next portion in case the calf has still drinking right.

The rod electrode is covered:

When an animal with drinking right enters the feeding box and is identified, the remaining portion in the mixer is stirred. After the calf has drunk the remaining portion, i.e. the mixer jar is empty and the rod electrode is free again, the automatic calf feeder starts preparing the next portion.

Two sucking stations:

When an animal with drinking right is identified, the relevant suction line opens. When the animal has no drinking right anymore, the suction line closes as soon as the rod electrode is free again and the entered draining time has lapsed. When the rod electrode is still covered, the suction line will close after approx. 2 minutes.

6.2.2 In the Ad Libitum Mode

In the ad libitum mode the automatic calf feeder operates without animal identification. As soon as the rod electrode is free, the machine starts preparing the next portion. In case of two sucking stations, both suction lines are open.

In case of prolonged ad libitum mode the 2-group valve unit heats considerably. Therefore, connect the suction hoses directly to the mixer and plug out the plug of the 2-group valve unit.

7 Settings in Setup

You have to set all basic functions of the automatic feeder in Setup.

Warning: Refer activation of these functions only to qualified personnel! The manufacturer has already provided the machines with the correct settings. The manufacturer accepts no responsibility for incorrect settings that have been carried out by the user.

7.1 Different selections in Setup

The Setup contains the following selections (see following table):

Language You may choose between the following languages: German, English, French, Netherlands, Italian, Norwegian, Swedish, Danish, Finnish, Polish, Japanese, Spanish and Czech.

The Eproms always contain the following languages: German, English and the target language.

EPROM
German
English
+ target language

Machine type In this menu please select the type of automatic feeder:
Powder- the automatic feeder only runs in the milk powder+water mode.
Combi- the automatic feeder works with fresh milk as well as with milk powder.
Milk- the automatic feeder only works with fresh milk.
KR- these automatic feeders run without feeding computer in the ad libitum (adlib) mode.

Interface Depending on the installed interface you have to set one of the following options:
Option „**No Interface**“ - the automatic feeder runs in the adlib mode without connection to the feeding computer.
Option „**Relay signal**“ - the automatic feeder is controlled by a feeding computer with Station Controller. The automatic feeder gets the relay and ready signals from the feeding computer.
Option „**Priority**“ - this option indicates which feeding station or calf group should be fed as a matter of priority. The automatic feeder runs in the ad libitum mode with a two-group valve unit and feed sensors.
Options „**Alcom-Bus**“ and „**VC3-Bus**“ are reserved to the connection to Bus-systems.

Box 1
Box 2 In case the automatic feeder is equipped with a stop valve for one feeding station or with a two-group valve unit for two feeding stations, you have to select the box valves in Setup. In addition, here you have to enter whether box 1 or box 2 are equipped with servo- or gradient control. Select „no“ if you want to cancel or you do not want to register a box.

Additive dispenser In case an additive dispenser is connected and additives should be dispensed, select the additive dispenser in Setup.

Calibration scales Do not modify the standard setting „no“.

Heating system Do not modify the standard setting „Heating system, thermostat“.

- Min.oper.therm.** This option indicates whether the automatic feeder has a thermostat for minimum operating temperature.
- Air valve** Select „yes“ in menu „air valve“ when the automatic feeder is equipped with compressed air cleaning.
- Detergent pump** In case the automatic feeder is equipped with a detergent pump and should the mixer be cleaned with detergent, you have to select the detergent pump in Setup.

7.2 Function Table „Setup“

Setup	Option
Language	deutsch
	english
	target language
Machine Type	Powder
	Combi
	Fresh milk
	KR
Interface	no Interface
	relay signal
	priority
	Alcom-Bus
	VC3-Bus
Box 1 / Box 2	yes/no/servo/gradient
Additive Dispenser	yes/no
Calibration scales	yes/no
Heating system	thermostat/electronic
Thermostat for Minimum Operating Temperature	yes/no
Air valve	yes/no
Detergent pump	yes/no

7.3 How to make entries in Setup

When switching the automatic feeder on, **only** press the „Menu“ key on the operating unit and keep it pressed until the display shows:

language
*deutsch

Press Enter, select the language by means of Arrow Up/ Arrow Down and confirm with Enter.

Now call up the other available menus by pressing Arrow Up/ Arrow Down. For modifications, press Enter to open the memory. Select the desired option by pressing Arrow Up/ Arrow Down. Confirm with Enter.

All selected options are marked by an asterisk*.

In order to leave Setup, switch the automatic feeder off and then on. In this way, all modifications will be activated.

7.4 Connecting the System-Machine to the Feeding Computer

You can connect the System-Machine to a feeding computer by means of the relay interface.

Set the operating mode in menu „Portion values“ of the System-Machine:

Switch the System-Machine off by turning the main switch to position „OFF“ and subsequently switch it on by turning the main switch to position „ON“. When switching the machine on, keep „Menu“ key pressed until the display shows submenu “Language”. Press Arrow Down to move to menu „Interface“. Press Enter. Press Arrow key until the display shows the option „Relay Signal“. Confirm with Enter. In order to activate the selected functions, switch the machine off and subsequently on.

```
interface
*relay signal
```

Set the operating mode in menu „Portion values“ of the System-Machine:

Press „Menu“ key. Press Arrow Down to move to menu „Portion values“. Press Enter to go to the submenus.

```
portion values
```

Press Arrow Down to go to submenu „Operating mode“ and select „restr. fix con.“ (restricted fix concentration) or „restr. var. con.“ (restricted variable concentration), depending on the feeding computer. The selected operating mode has to correspond to the one on the feeding computer.

```
operating mode
*restr.fix con.
```

Connecting the System-Machine to the Relay-Interface

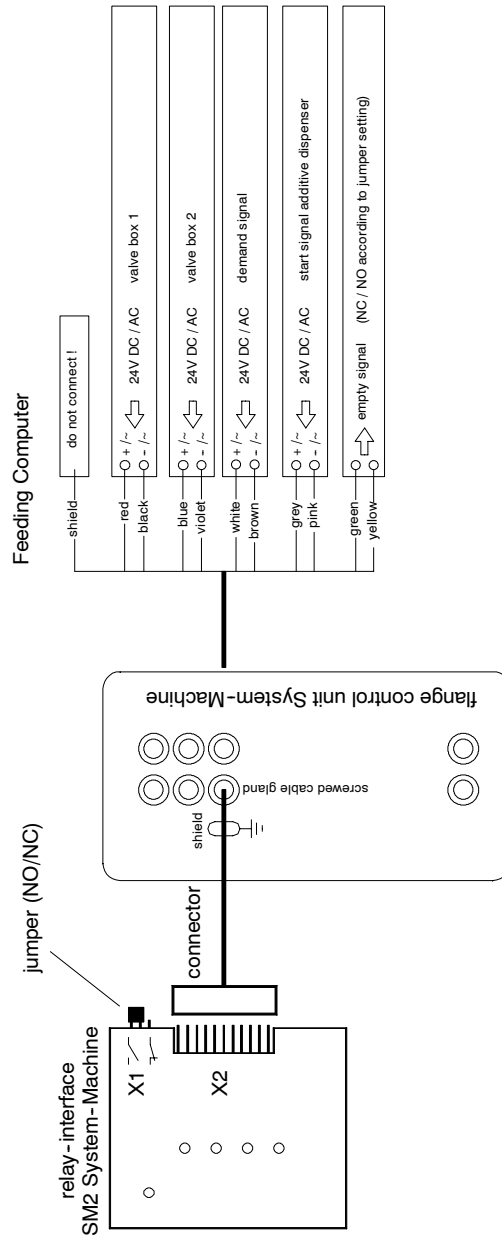

8 Functions of the Menu Key

The functions of the „Menu“ key are summed up in the following main menus:

- Hand Functions,
- Portion Values,
- Calibration,
- Machine Values,
- Diagnosis.

Press Enter in the desired main menu and access the various available submenus or subfunctions.

Press Arrow Up/Arrow Down to move to the different submenus within a main menu. In case you are in a submenu yet, press Menu key to return to the main menu level.

Depending on the basic settings carried out in Setup, particular menus are not displayed on the screen.

8.1 Hand Functions

In the main menu level you can access the first main menu „Hand functions“ by pressing the Menu key once again. In this menu you can activate the functions of the automatic feeder individually and manually.

You may choose between the following functions:

- Emptying Mixer
- Water Boiler, Start
- Milk Powder, Start
- Additive, Start
- Mixer, Start
- Box Valve 1/2, Open
- Boiler, Fill

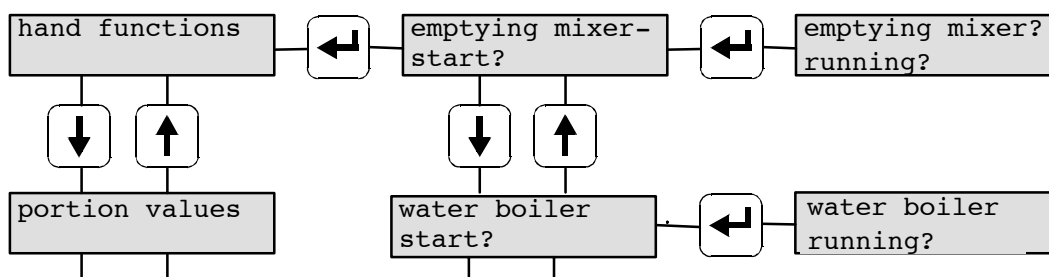

Release the Enter key to complete the operation.

8.2 Portion Values

In the main menu „Portion values“ you can enter the operating mode as well as the values of the portion that should be prepared.

You may choose between the following submenus:

- Concentration
- Additive
- Operating mode

8.2.1 Selecting the Concentration

The concentration of the milk is defined as the amount of milk powder distributed to each calf per liter milk.

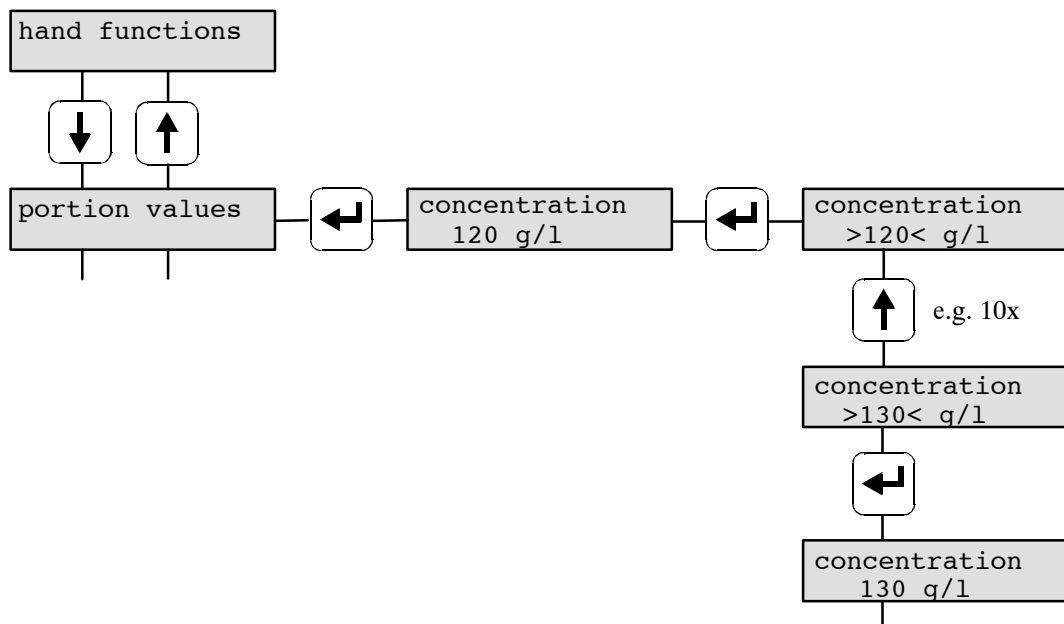

Thanks to particular feeding computer programs you can enter an animal-specific, variable concentration. In this case, the System-machine does not display submenu „Concentration“ anymore. You have to enter the concentration value into the feeding computer.

8.2.2 Entering the Additive

Calves can be treated either with powder or with liquid additives. In submenu „Additive“ you have to enter the amount of additive in grams per liter that should be added to each drinking portion. The feeding computer determines which drinking portion should be prepared and distributed with or without additive.

Thanks to particular feeding computer programs you can enter an animal-specific, variable additive share. In this case, the System-Machine does not display submenu „Additive“ anymore. You have to enter the additive value into the feeding computer.

8.2.3 Restricted/Adlib-Mode

The automatic calf feeder runs as a standard in the restricted mode but you can also commute to the ad libitum mode.

Restricted In the restricted mode the automatic calf feeder operates with animal identification, i.e. calves are fed individually and in a restricted way.

Ad Libitum In the ad libitum mode the automatic calf feeder operates without animal identification and without connection to the feeding computer. In the feeding mode, a new portion is prepared each time the electrode in the mixer jar is free. Should two sucking stations be connected to the automatic calf feeder, both feeding boxes are open. All calves get the concentration set in the menu „Portion values, Concentration“.

Press Menu key to enter the operating mode. Press Arrow Down to move to menu „Portion Values“. Press Enter once again to move to the submenus. Press Arrow Down to go to submenu „Operating mode“. Press Enter. Press Arrow Up/Arrow Down to select the desired operating mode and confirm with Enter. The selected operating mode is marked by an asterisk.

8.3 Calibration

8.3.1 Calibrating Water and MP (milk powder)

Calibration is defined as the input into the computer of the amount of water and MP distributed during a fixed period of time. Only enter the value corresponding to the amount that has actually been distributed. The machine type determines which submenus are displayed.

In case the feed components have not been calibrated at all or only inaccurately, the automatic feeder cannot prepare the exact feed mix in feeding mode. The manufacturer does not accept any responsibility for errors due to inadequate calibration.

The calibration process of the feed components is always the same:

First press the „Menu“ key and move to menu „Calibration“ by means of Arrow Down. Then press Enter to access the submenus. Hold an empty measuring vessel under the discharge. Press Enter. The automatic feeder distributes the quantity of - e.g. - water that has been calibrated. The set quantity is displayed on the screen. The displayed message changes as soon as the water has been distributed. Now press Arrow Up/Arrow Down to enter the amount dispensed and measured and confirm with Enter. The message „Water start“ is displayed again.

Repeat the calibration process, in order to be sure that the target quantity has been attained.

Example for the calibration of water:

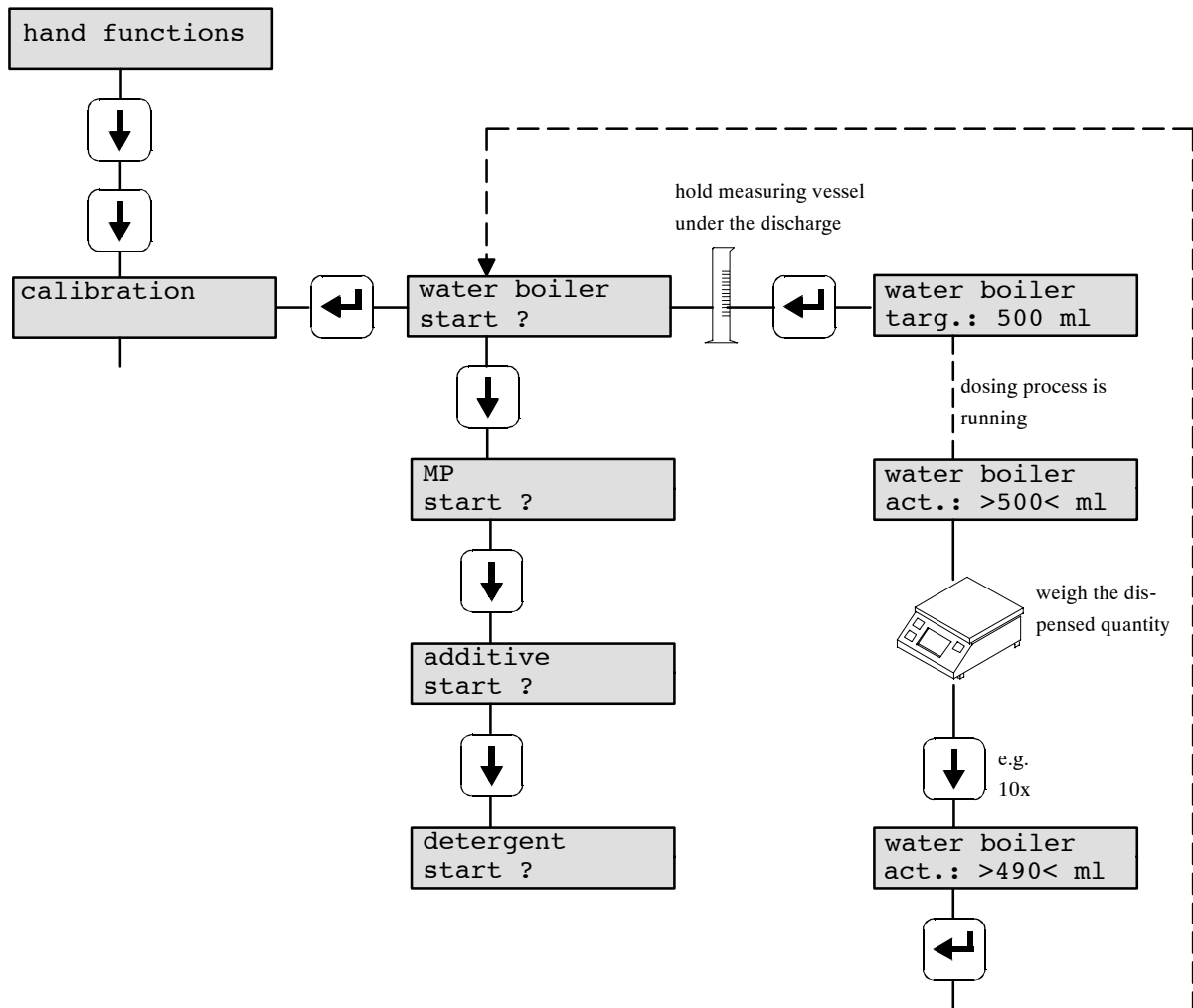

Calibrate all components that can be selected in the submenus!

8.3.2 Calibrating Additives and Detergent

When the automatic feeder is equipped with an additive dispenser or with a detergent pump and should the mixer be cleaned with a detergent, you have to calibrate the additives and the detergent, too.

Weigh out the powder additives with precision scales (e.g. electronic scales). The weighing accuracy has to be 1/10 g. Hold the measuring vessel under the discharge. Press Start/Stop key. Weigh the dispensed quantity and enter the measured, resp. weighed value.

In case there are no available precision scales, repeat calibration a number of times, in order to get a larger quantity of additive. Then divide the measured quantity by the number of calibration processes and enter the value.

Measure liquid additives and detergent by means of a cylinder.

Repeat the calibration procedure, in order to be sure that the target quantity has been attained.

The warning „Amount too small“ indicates that the dispensed amount was too small and the target amount has not been reached. Repeat calibration process once again.

```
additive
amount too small
```

```
detergent
amount too small
```

8.4 Machine Values

The main menu „Machine Values“ contains the following submenus:

- Intermediate Mix
- Afterrun Mixer
- Emptying Mixer
- Distribution Pause
- Box 1 / Box 2

8.4.1 Intermediate Mix

Press „Menu“ key. Press Arrow Down to move to the main menu „Machine values“.

```
machine values
```

Press Enter. The display shows:

```
intermediate mix
0 min
```

In this menu you can enter whether and after which time an intermediate mix has to be carried out. You may enter 5 to 60 minutes. The figure 0 means that the intermediate mix is not active.

The intermediate mix only takes place when the level electrode is covered.

8.4.2 Mixer Afterrun

In this menu you can enter how many seconds the mixer has to run after the last feed portion has been dispensed.

Press Menu-key. Press Arrow Up/Arrow Down to move to main menu „Machine values“.

machine values

Press ENTER and then Arrow Down. The display shows the following message:

afterrun mixer
3 s

Press ENTER again. Press Arrow Up/Arrow Down to enter the desired time and confirm with ENTER. You can enter 3 to 12 seconds.

8.4.3 Emptying Mixer

Press Menu-key. Press Arrow Down to move to main menu „Machine values“.

machine values

Press ENTER and Arrow Down. The display shows „Emptying mixer“. Here you can enter after which time the mixer has to be emptied. You can enter between 0 (=the mixer is not emptied) and 60 minutes.

emptying mixer
0 min

When a calf does not claim its milk portion at all or in case it only claims it partially, the milk can be drained off into the mixer jar via the mixer outlet valve after the entered time has lapsed.

8.4.4 Entering the Distribution Pause

The distribution pause regulates milk distribution. As soon as the automatic feeder starts to prepare the milk portion, the stop valve or the two-group valve unit close for the duration of the entered distribution pause. It is advisable to set a distribution pause only in case of not readily soluble milk powders or in case of very high concentrations (> 200 g/l) and extreme drinking speed (> 2 l/min).

Press Menu-key. Press Arrow Down to access main menu „Machine values“.

machine values

Press Arrow Down to move to submenu „Distribution Pause“. Confirm with ENTER.

distrib.pause
0 sec

Press Arrow Up/Arrow Down to select the distribution pause. Only enter values between 0 and 16 seconds (Standard value: 0 s).

distrib. pause
0 sec

8.4.5 Box 1 / Box 2

When the feeding station is additionally equipped with **servo-** or **gradient control**, here you can enter **turn-on** and **turn-off** delay. Possible entry: 0 to 2 seconds.

Press Menu-key. Press Arrow Down to move to main menu „Machine values“ and confirm with ENTER.

machine values

Press Arrow Down to move to submenu „Box 1 / Box 2“. Press ENTER.

box 1

Press Arrow Down to move to „turn-on delay“.
Press ENTER. Press Arrow Up/Arrow Down to select turn-on delay and confirm with ENTER.

```
turn-on delay
1.2 sec
```

Same procedure for turn-off delay.

```
turn-off delay
0.8 sec
```

8.5 Diagnosis

The main menu „Diagnosis“ facilitates trouble shooting. In addition, motors, valves and pumps can be controlled individually.

Press Menu key. Press Arrow Down to move to the main menu „Diagnosis“:

```
diagnosis
```

8.5.1 Valves/Motors

In the following submenus each output can be controlled individually. The function of each individual output is displayed on the screen. In this way it is possible to check whether the output and the control are running well.

Press Arrow Down to go to the submenus.
The display shows:

```
water valve bo.
open ?
```

Press Enter to open the water valve. The water valve is open so long as you press the Enter key.

```
water valve bo.
opened !
```

The same applies to

the other valves:

- Mixer outlet valve
- Air valve
- Box valve 1/2

and the motors:

- Mixer
- Powder motor
- Additive dispenser
- Detergent pump
- Feeding pump

8.5.2 Sensors

The sensors, such as e.g. the supply and the rod (level) electrode as well as the thermostat for minimum operating temperature are part of the inputs. The display shows each change of the state of the sensors limiting the occurrence of faults.

The display shows e.g.:

```
rod electrode
hit !
```

The same applies to:

- Point electrode

- Supply electrode
- Temperature
- Detergent

8.5.3 Calibration

In this submenu you can check duration of dispense of the relevant feed component resp. of detergent (Boiler water; MP; Additive; Detergent). The following example concerns boiler water but it also fits to all other components:

Press Arrow Down to move to submenu „Calibration“.

```
calibration
```

Press ENTER twice...

```
water boiler
```

...until the display shows running time.

```
running time
x:xx sec
```

Same procedure for MP, additive and detergent.

8.5.4 Interface

In this submenu you can check whether

- the feeding computer transmits a signal to the automatic feeder for the request of a milk portion. The display shows: „Signal portion active/not active“
- the feeding computer transmits a signal to the automatic feeder for the request of a milk portion with additive. The display shows: „Signal additive active/not active“
- the feeding computer transmits a signal to the automatic feeder for the selection of a feeding station. The display shows: „Selection box 1/2“
- the automatic calf feeder transmits a signal to the feeding computer when the mixer jar is empty. The display shows: “Signal ready, activate”.

8.5.5 Checking

In menu „Checking“ the second line of the display shows the number of power failures, data backups on the memory chip, cleaning faults as well as water checks.

In submenu „Power failures“ you can view the number of reboots of the automatic feeder after power failure:

```
power failures
2
```

In case of memory data error, the computer can fall back upon an internal backup in submenu „Backup“. Each backup is counted.

```
back-up
1
```

In submenu „Cleaning fault“ you can view faults that occurred during automatic cleaning.

```
cleaning fault
2
```

In submenu „Check water“ you can view the number of water checks that have been carried out because the electrode has not been hit at all or not enough by the water jet.

```
check water
0
```

Clear fault messages as follows: Press ENTER. Press Arrow Up/Arrow Down and select „0“. Confirm with ENTER. Then press ENTER again, in order to confirm the input.

8.6 Version

Here you can read EPROM's version number.

System-Machine xxxx-xx x.xx

8.7 Function Table of the Menu-Key for Connection to Feeding Computer

In case the System-Machine is connected to a feeding computer, you can select the following functions (as of program version 01.01):

Menu	Submenu	
Hand Functions	Emptying mixer start?	
	Water boiler start?	
	MP start?	
	Additive start?	
	Mixer start?	
	Box valve 1 open?	
	Box valve 2 open?	
	Boiler fill?	
Portion Values	Concentration	xxx g/l
	Additive	x g/l
	Operating mode	Restr. fix conc.
		Restr. var. conc.
Ad libitum		
Calibration	Water boiler start?	targ.: xxx ml
	MP start?	targ.: xxx g
	Additive start?	targ.: xx g
	Detergent start?	targ.: xx ml
Machine Values	Intermediate mix	x min
	Afterrun mixer	x sec
	Emptying mixer	x min
	Distribution pause	xx sec
	Box 1/2	Turn-on delay
		Turn-off delay
Diagnosis	Valves	Water valve boiler open?
		Mixer valve open?
		Air valve open?
		Valve box 1/2 open?
	Motors	Mixer start?
		Powder motor start?
		Additive dispenser start?
		Detergent pump start?
		Feeding pump start?

Diagnosis	Sensors	Rod electrode covered/free?
		Point electrode covered/free?
		Supply electrode covered/free?
		Temperature ok/too low?
		Detergent?
	Calibration	Boiler water; MP; additives; detergent
	Interface	Signal portion active/not active
		Signal additive active/not active
		Selection box 1/2 active/not active
		Signal ready activate
	Checking	Power failures
		Back-ups
		Cleaning fault
		Water check
	Version	System-Machine

Depending on the basic settings carried out in Setup, some particular menus are not displayed on the screen of the System-Machine.

9 Functions of the Automatic Key

After pressing the Automatic key, the feeder runs in the automatic mode. The green pilot lamp lights. The automatic feeder starts preparing a milk portion as soon as the feeding computer transmits the corresponding signal.

In case faults should occur in the automatic-mode, the green pilot lamp will go out. See chapter 12, page 55, „Fault messages“.

9.1 Display in the Automatic-Mode

When the automatic feeder runs in...

...MP-mode...

```
MP-mode
mixer:      full
```

or in

....ad lib-mode....

```
adlib-mode
mixer:      full
```

the above information is displayed on the first line of the screen. In the second line you can view the state of the mixer: „full“=the rod (level) electrode is covered or „empty“=the rod electrode is free.

Please note: Press Arrow Down to scroll the text on the display. The information displayed last in the second line of the screen will appear in the first line of the following screen.

„Full“ means that the level electrode in the mixer is covered.
„Empty“ means that the level electrode in the mixer is free.

```
MP-mode
mixer:      empty
```

```
mixer:      empty
calf: xxxx
```

When an animal is in the feeding station, the display shows the relevant Responder number.

```
calf: xxxx
entitl.: xx.x 1
```

When an animal is in the feeding station the relevant feed entitlement is displayed on the screen. In case the automatic feeder is equipped with a two-group-valve unit that has been activated in Setup, the display shows the following message: The open box valve is marked by an asterisk*.

```
entitl.: xx.x 1
box:    1*  2-
```

In case the automatic feeder is equipped with a two-group-valve unit that has been activated in Setup, the display shows the following message:

```
box: 1*    2-
feed:   xx.x 1
```

The open box valve is marked by an asterisk*.

Keep the Automatic-key pressed for approximately 2 seconds, in order to set the feed amount to zero.

After that, the display shows the feed quantity that has been dispensed until then.

```
feed: xx.x l
cl. mix.: n. act.
```

The next screen displays the cleaning activities of the automatic feeder. In case „clean mixer“ has not been activated in the cleaning settings (clean mixer = 0 hours), the display shows „n. act.“ (not active) in the first line.

```
cl. mix.: n. act.
air cl.1: active
```

„Mix. f.“ (= Mixer full) means that the time for mixer cleaning has come but the mixer jar is not empty yet and the level electrode is earthed.

```
cl. mix.: mix.f.
air cl.1: active
```

Draining time (= d.time) starts as soon as the calf has drunk its milk portion and the level electrode is not earthed/covered anymore. After draining time has lapsed, the automatic feeder starts mixer cleaning.

```
cl. mix.: d.time
air cl.1: active
```

As feed distribution has priority over cleaning, a „pause“ has been incorporated into the SM2Plus-system. This means: if, within five minutes after dispense of the last portion, no further calf requests its milk portion, the automatic feeder starts mixer cleaning.

```
cl. mix.: pause
air cl.1: active
```

After mixer cleaning has been completed, the display shows the following message:

```
cl. mix.: clean
air cl.1: active
```

When air cleaning is active at box 1, the display shows the following:

```
air cl.1: active
air cl.2: n. act.
```

The same applies to air cleaning at box 2.

```
air cl.2: active
```

As soon as the level electrode is free, a milk portion is prepared. The second line on the screen shows - starting from the left - the values relating to the currently prepared portion: concentration (g/l), additive (g/l).

```
distribution
120g      25g
```

9.2 Releasing an Extra-Portion

In the Automatic-mode, a milk portion can be released as soon as the rod electrode is free.

Keep ENTER pressed for about 2 seconds. The displayed concentration value starts flashing. Press Arrow Up/Arrow Down to set the required concentration. Immediately afterwards confirm with Enter.

```
extra-portion
>120 g/l<
```

A milk portion is mixed up. Meanwhile the display shows the values of the portion that is being prepared.

```
distribution
120g/l      0g/l
```

After the milk portion has been mixed up, press Arrow Up / Arrow Down to enter the number of the feeding station where the milk portion should be distributed. Confirm with Enter.

```
extra-portion
>*box 1<
```

After draining time has lapsed, the automatic feeder returns automatically to the Automatic-mode.

10 Functions of the Cleaning Key

When pressing the Cleaning key, the automatic feeder commutes from the automatic mode to the cleaning menu.

Press the Automatic key again in order to return to the Automatic-mode.

The cleaning processes can be interrupted at any time by pressing any main menu key or ENTER. In case you have utilized some detergent during the main cleaning process, you can switch back to the Automatic-mode only after the automatic feeder has carried out after-rinsing.

The **Cleaning Menu** contains the following functions:

- Cleaning mixer
- Air cleaning
- Settings

In **submenu Settings** you can set all values needed to carry out time-controlled, automatic cleaning processes.

- Cleaning mixer
- Air cleaning
- Detergent

10.1 Entering the Figures

Press Arrow Up/Arrow Down and then ENTER in order to enter figures. In case of **manual activation** of „Cleaning Mixer“, in menu „**Cleaning**“ you can enter the detergent amount provided that you have previously selected the detergent pump in Setup (see following illustration). In submenu „**Settings**“ you can change the number of daily **automatic** mixer cleaning processes as well as the corresponding detergent amount. In order to access this submenu, press the Cleaning key located on the panel and subsequently Arrow Down.

Press ENTER to modify a figure. The displayed figure starts flashing (e.g. >20<). Arrow Up is used to increase and Arrow Down to decrease the figure. The longer you keep the relevant Arrow key pressed the faster the displayed figure is going to be modified. Once you set the correct figure, press ENTER again to store it (the figure stops flashing). In case you do not wish to modify the figure, press the Menu key to return to the main menu.

Example for the input of figures within the functions of the **Cleaning** key:

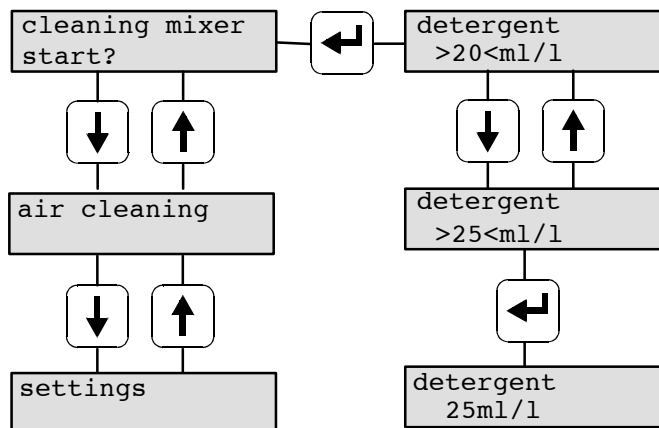

10.2 Selecting the Options

You can only select one of the available options. The selected option is marked by an asterisk in the second line of the display.

Press ENTER to change the option. The displayed option starts flashing. Press Arrow Up/Arrow Down to scroll the available options. Press ENTER to confirm the desired option. This option is marked by an asterisk and stored. In case you do not wish to modify the option, press the Cleaning key once to return to the corresponding submenu.

Example for the selection of options within the functions of the submenu „Settings“:

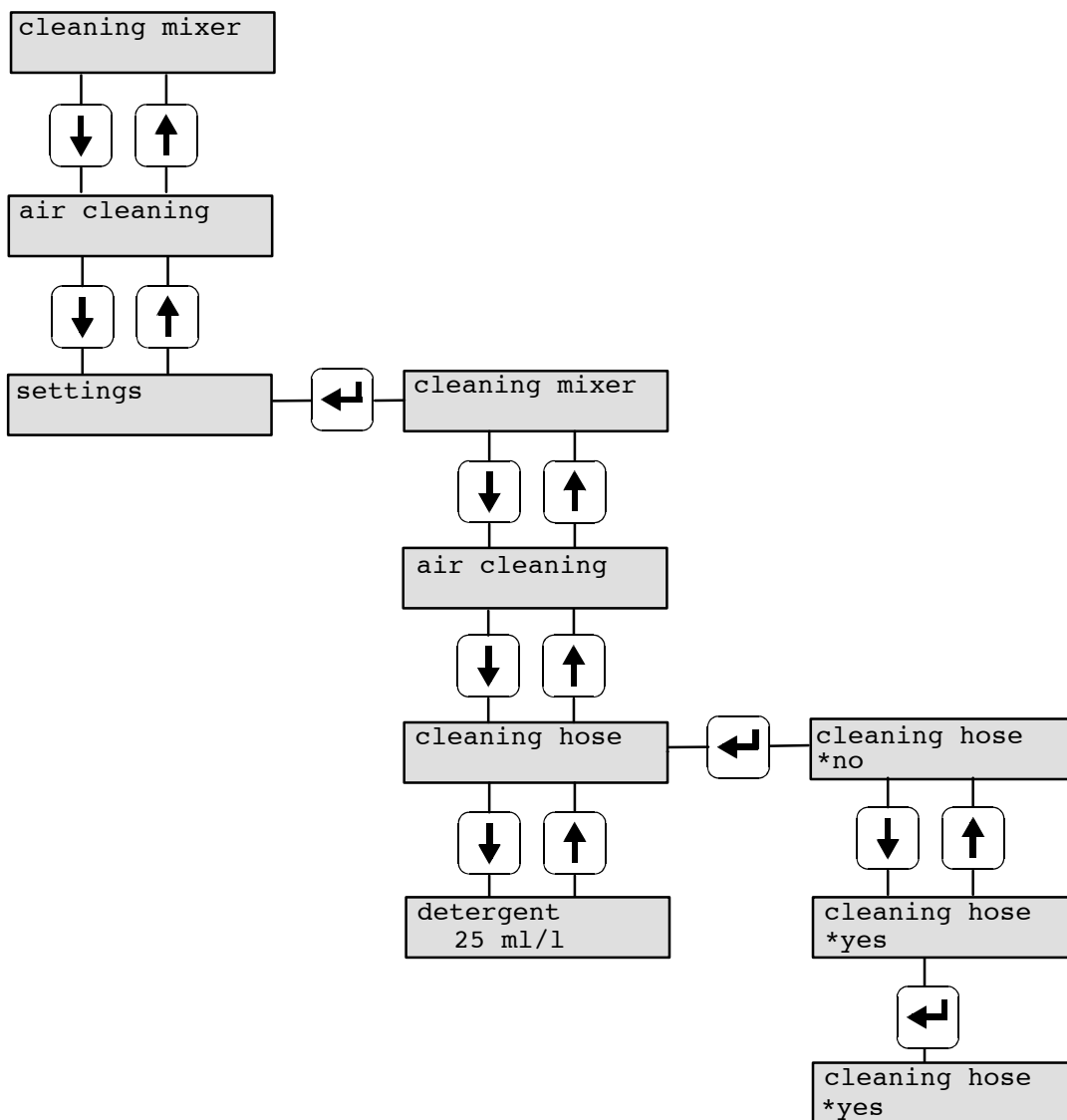

10.3 Cleaning



CAUTION! In order to avoid injuries, **before** carrying out any kind of operation on the mixer, such as e.g. manual evacuation of rinsing water, it is imperative to make the automatic feeder currentless by turning the main switch to position „0/OFF“ or by pulling the mains plug.

10.3.1 Mixer Cleaning

Press the Cleaning key to call up automatic mixer cleaning manually at any time.

Press ENTER to confirm „Cleaning“. The display shows:

```
cleaning mixer →
start?
```

In case you have not activated the detergent pump in Setup, the automatic cleaning cycle starts running without detergent. If necessary, add some detergent manually to the water.

In case you have activated the detergent pump in Setup, the display shows the following message:

```
detergent
10 ml/l
```

Change or maintain the pre-set detergent amount. You may enter values between 0 and 25 ml. Confirm with ENTER. Automatic cleaning starts running.

When the rod electrode is covered, the remaining portion in the mixer jar is drained off via the mixer outlet valve before each cleaning. **Prerinsing** starts running with 0,5 liters of water.

```
cleaning mixer
prerinsing
```

The main cleaning process is carried out with 1,3 liters of water and the entered detergent amount.

```
cleaning mixer
remain. 3:00
```

After the mixer has run for 3 minutes (time runs backwards from 3 to 0 minutes), the liquid in the mixer jar is drained off via the mixer outlet valve. The display shows:

```
cleaning mixer
emptying mixer
```

After the mixer jar has been emptied completely, afterrinsing is carried out with 1,5 liters of water being delivered into the mixer jar where they are stirred for 20 seconds and subsequently drained off via the mixer outlet valve.

```
cleaning mixer
afterrinsing
```

When mixer cleaning has been completed, the display shows:

```
cleaning mixer
finished!
```

In case the water cannot be drained off via the mixer outlet valve within 2 minutes (the rod electrode is still covered), the alarm message „Emptying Mixer“ is displayed. If neces-

sary, check whether the suction hose or the mixer outlet valve are blocked. Tip out the rinsing water in the mixer jar (refer to above-mentioned safety instructions).

In case detergent has been added to the cleaning water, feeding mode is interrupted until the fault has been cleared.

In case no detergent has been added to the cleaning water, the fault message on the screen disappears as soon as a calf drinks up the liquid in the mixer jar.

Make sure that there is a water discharge next to the automatic feeder. If that is not the case, hang the mixer outlet hose into a bucket.

Empty the bucket regularly. Do not dip the mixer outlet hose into the cleaning water.

After mixer cleaning has been completed, press Automatic key to return to the Automatic-mode.

Notes on automatic mixer cleaning (time-controlled)

When the rod electrode is covered, the automatic mixer cleaning is deferred for 1 hour at most so that a calf has the opportunity to drink up the liquid in the mixer jar. In case the calf does not drink up the liquid within this time, the liquid is drained off via the mixer outlet valve and prerinsing starts running. As soon as the mixer jar is empty again, the main cleaning cycle with detergent starts running.

The mixer can be cleaned automatically up to nine times/day with detergent – provided that the automatic feeder is equipped with a detergent pump that has previously been selected in Setup.

10.3.2 Air Cleaning

Compressed air cleaning (hereinafter called air cleaning) facilitates cleaning of the suction hoses up to the top of the teat without detergent. In order to ensure perfect cleaning, make sure that air pressure is between 2 and 2,5 bar. Compressed air should be supplied by an oil free compressor with pressure reducer and a liter output ≥ 100 l/min.

Please note: Air pressure exceeding 2,5 bar may damage the diaphragm inside the milk solenoid valves.

In this menu you can activate air cleaning manually at any time, provided that the automatic feeder is equipped with a device for air cleaning that has previously been registered in Setup.

Proceed as follows:

Press Cleaning key. The display shows:

cleaning mixer
start?

Press Arrow Down to select submenu „Air cleaning“.

air cleaning
start?

Press ENTER to move to the next screen. Enter the number of the box where air cleaning should take place. Press ENTER to start cleaning.

air cleaning
*box 1

10.4 Settings

Menu „Settings“ contains all settings relating to automatic cleaning of the mixer (with or without detergent) as well as to air cleaning.

10.4.1 Mixer Cleaning

Press Cleaning key and then Arrow Down. The display shows:

settings

Confirm with ENTER. You can enter 0 (automatic mixer cleaning will not take place) to 9 times/day.

cleaning mixer
x hours

10.4.2 Air Cleaning

Press Cleaning key and then Arrow Down until „Settings“ is displayed. Press ENTER to open the submenu.

settings

Press Arrow Down to move to „air cleaning“ and then press ENTER. Enter the time that has to pass by after distribution of the last portion before air cleaning starts running.

air cleaning
x min

10.4.3 Detergent

In menu „Settings, detergent“ you can enter the amount of detergent that should be added to the water during automatic mixer cleaning.

Press Cleaning key and then Arrow Down. Confirm with ENTER.

settings

Press Arrow Down. You can enter 0 (no detergent is added to the water) to 25 ml/l.

detergent
10 ml/l

11 Service and Maintenance of the Automatic Calf Feeder

- Always keep the automatic calf feeder clean and dry. Never spray it with water!

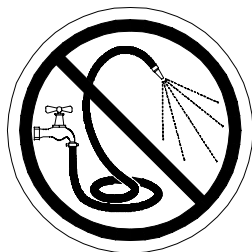

CAUTION! In order to avoid injuries, **before** carrying out any kind of operation on the milk powder outlet, it is imperative to make the automatic feeder currentless by turning the main switch to position „0/OFF“ or by pulling the mains plug.

- Carry out daily check of the powder outlet and, if necessary, remove incrustations. Incrustations impair dosing precision.

Always remove incrustations of the powder outlet by means of a small piece of wood or similar. Never use your fingers!

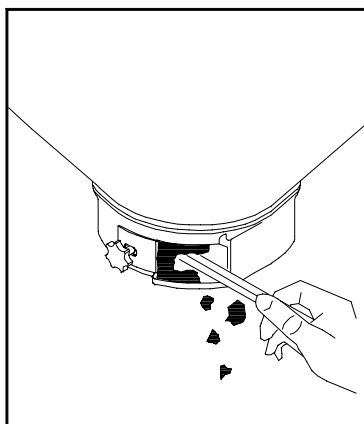

11.1 The Day after the First Commissioning

- General function check:
 - check calibration values
 - measure the milk temperature
 - make sure that the calves are reliably identified.

11.2 Carrying Out a Regular Check Routine

- Measure the temperature of the milk by using a precision thermometer.
- Check calibration of the milk powder at least after each new delivery.

- Check calibration of the water amount.

11.3 Shutdown

Before shutdown:

- Remove all residual (rinsing) water from the system. Turn the thermostat for minimum operating temperature and the heating thermostat entirely counter clockwise.
- Switch the calf feeder off by turning the main switch to position „0/OFF“ and pull the mains plug.

After shutdown:

- The automatic calf feeder has to be in a dry location.
- Keep the connections on the control unit closed by means of closing caps.
If not, moisture may penetrate the control unit.

In case of frost risk:

- Let the water flow out of the solenoid valves and the pressure reducer.

Commissioning the automatic calf feeder once again:

- When commissioning the feeder again, check whether there is enough water in the boiler.
- Proceed as for first commissioning.

12 Fault Messages

In case fault messages should occur, in main menu „Diagnosis“ you can control each individual actuator. *See chapter 8.5, page 39, „Functions of the Menu Key, Diagnosis“.*

As soon as a fault message occurs, the green pilot lamp indicating that the automatic feeder is working in the automatic mode goes out.

12.1 Memory Error

When starting the System-Machine, all program data stored in the memory chip will be checked.

In case of faulty data, the display shows:

```
memory error
```

Switch the System-Machine off. Press the three keys „Auto-
matic“, „Cleaning“ and „Menu“ simultaneously while switch-
ing the System-Machine on. Keep the keys pressed until
the following message is displayed:

```
initial memory
```

Immediately afterwards, carry out new programming of Setup. Carry out calibration once again. Check portion values and machine values. See chapter 14, page 60, „Replacement of the program chip“.

12.2 Temperature

When the feeding mode is cut off because the minimum operating temperature has fallen below the standard figure, the display shows:

```
fault
temp. too low
```

- Check position of the thermostats.
- Check the heating.
- Check setting of the minimum operating temperature. See chapter 5.6.1 „Adjusting the thermostats“, page 23.

The fault message disappears automatically as soon as the fault has been removed.

12.3 Electrode Fault

When the supply electrode is earthed before a portion is mixed up, feeding mode is cut off:

```
fault
supply electrode
```

- Check whether the supply electrode is earthed at the water outlet.

12.4 Lack of Water

When the water does not hit the supply electrode in water mode, the automatic feeder starts a water check. The automatic feeder tries to find out (up to 5 times) by means of a repeat

handle whether the water really does not come out of the outlet. After 5 vain attempts, identification as well as the preparation of the milk portions are cut off.

The display shows:

fault lack of water

- Check whether the water jet hits the supply electrode.
- Check the water supply to the automatic feeder.
- Press the Automatic key, in order to delete the alarm message.

12.5 Emptying Mixer

In case the liquid inside the mixer jar does not drain off because the mixer outlet is e.g. clogged, the display shows the following error message:

fault emptying mixer

- Check whether the mixer outlet is clogged.
- Check the mixer outlet hose and clean it, if necessary.
- Check electrodes.

In case before the detergent has automatically been added to the water, operation of the automatic calf feeder is cut off until the fault has been removed and after rinsing could be completed. In case no detergent has been automatically added to the water, the fault message on the display will disappear as soon as a calf has drunk up the liquid in the mixer jar.

13 Accessories

13.1 Two-Group-Valve-Unit

Thanks to the priority control with two-group-valve-unit, System-Machines can provide, in succession, two feeding stations with milk, i.e. when a calf with drinking right enters the feeding station the available milk amount for this calf is distributed without interruption while the other feeding station is blocked during this time. Change-over to the other feeding box takes place via the two-group-valve-unit.

The milk hose leads from the mixer outlet to the hose connection of the feeding pump that is located below the solenoid valves. The feeding pump is connected to the box valves by means of a PVC-joining piece. The box valves are connected to the feeding stations via suction hoses.

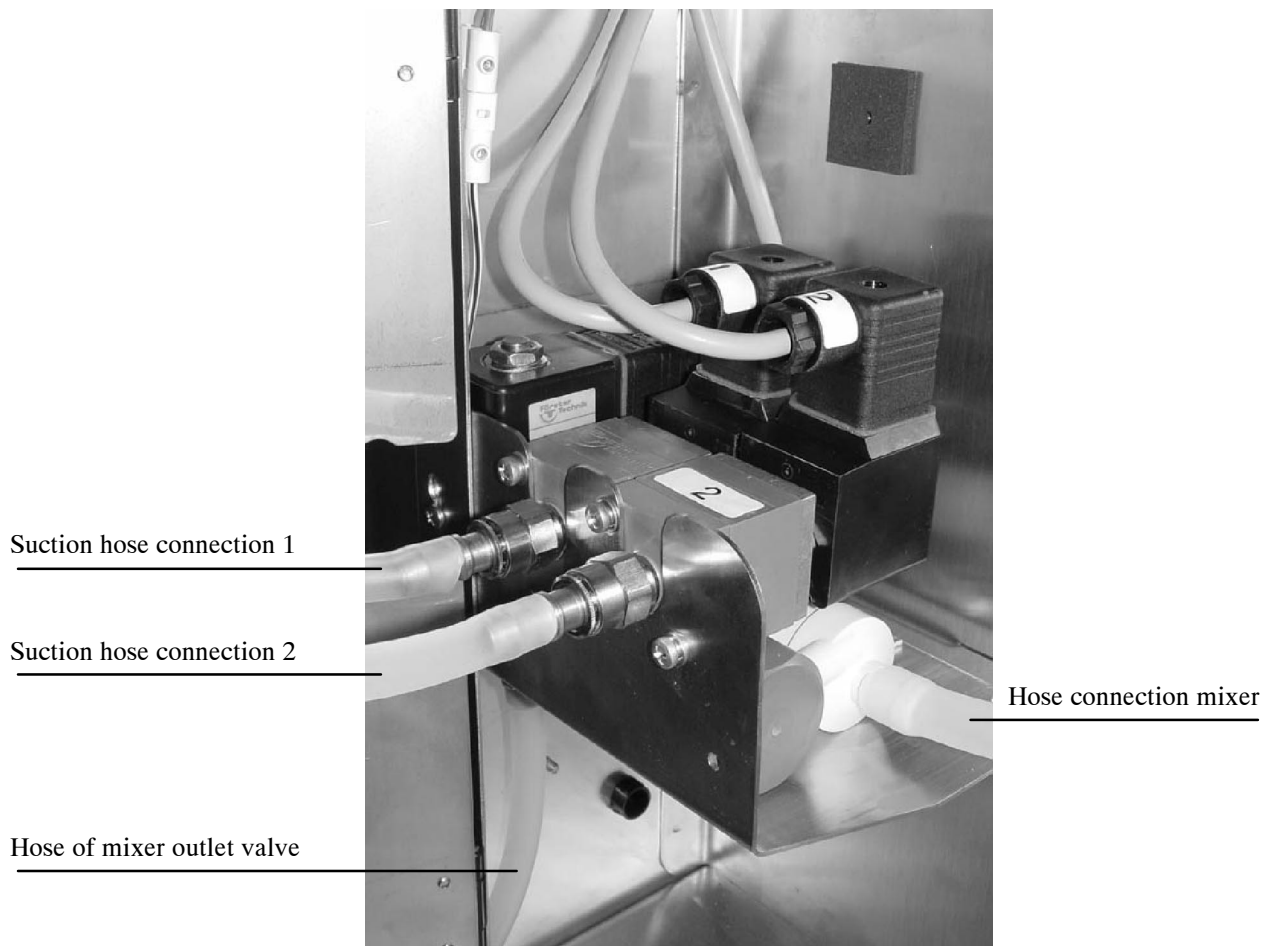

Take care that suction hose connection 1 runs to feeding station 1 (identification 1) and suction hose connection 2 runs to feeding station 2 (identification 2). In case you should not observe this order, a calf trying to get its milk portion at feeding station 1 will get no milk because the milk portion will be distributed at feeding station 2 instead.

13.2 Additive Dispenser



CAUTION! In order to avoid injuries due to **rotating parts on the powder outlet of the additive dispenser**, **before** carrying out any kind of operation on the additive dispenser, it is imperative to make the automatic feeder currentless by turning the main switch to „0/OFF“ or by pulling the mains plug.

You can only connect **one** additive dispenser to the automatic feeder (either for powder **or** for liquid additives). The automatic feeder is equipped as a standard with a cable with cubicle plug for the additive dispenser.

For mounting or installation of the additive dispenser, refer to instructions manual „Precision Doser for Powder Additives or Dosing Pump for Liquid Additives“.



13.3 Electrical Vapour Screen for MP- and Powder Additive Outlet

The electrical vapour screen consists of a heating element located right below the outlet for milk powder resp. powder additive. In case of bad weather conditions, such as e.g. too high atmospheric humidity, the electrical vapour screen should prevent the milk powder and the powder additive from sticking to the outlet.

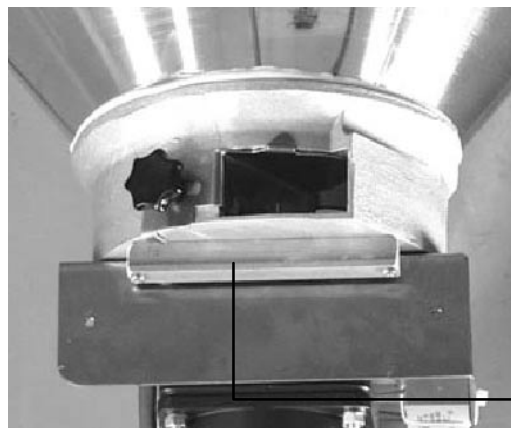

electrical vapour screen
for milk powder outlet

13.4 Detergent Dosing Pump

Thanks to the detergent dosing pump, liquid additives are added automatically to the water during the various cleaning cycles. There is no need anymore to add the detergent manually.

The detergent dosing pump is located in the left interior of the automatic calf feeder below the two-group-valve-unit. The detergent is taken from a container with a storage capacity of 1,5 liters and is conducted via a thin hose into the mixer jar. Before calibrating the detergent dosing pump you have to calibrate it.

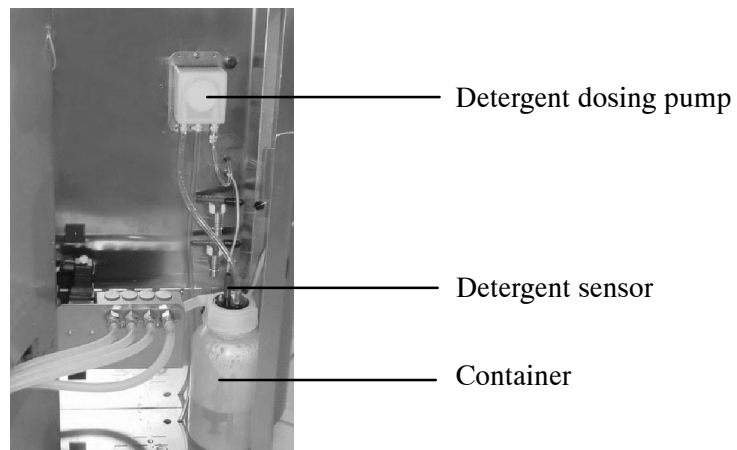

13.5 Protection against Flies

In case of fly infestation occurring particularly in summer we recommend to protect the mixer jar by means of a large fly screen. Water vapour can escape through the openings of the fly screen. You can attach the fly screen together with the dispenser for powder additives to the automatic calf feeder.



14 Replacement of the Program Chip

Refer replacement of the program chip only to qualified personnel.

Proceed as follows:

1. Before replacing the program chip, write down all machine settings. To this end, switch the System-machine off, press the Menu key while switching the machine on once again. Keep the Menu key pressed until the new program version is displayed. Note down all machine settings previously selected, such as e.g. language, machine type, interface etc.
2. Disconnect the System-machine and make it currentless.
3. Open the control-unit box and remove the old program chip (chip with adhesive label „SM2 Plus XX.XX“). Use appropriate tools, in order not to damage the strip conductors on the main circuit card. If necessary, remove the main circuit card.

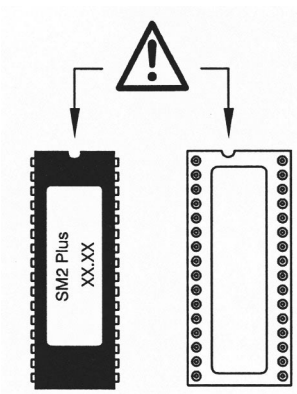

4. Put in the new program chip with the notch upwards.
5. Close the control-unit box.
6. Switch the System-Machine on. When starting the machine, the display shows the new program version. In case the message „Fault Memory error“ is displayed, switch the automatic feeder once again.
7. Press the three keys „Automatic“, „Cleaning“ and „Menu“ simultaneously and switch the System-Machine on. Keep them pressed until the display shows the number of the program version. Carry out new programming of Setup.
8. Carry out new calibration.
9. Check portion values and machine values.

A

accessories, 57
 additive dispenser, 58
 detergent dosing pump, 59
 electrical vapour screen, 58
 protection against flies, 59
 two-group-valve-unit, 57

ad libitum mode, 35
 milk distribution, 26

additive dispenser, 58

address, Förster-Technik, 6

air cleaning, 51, 52

animals per sucking station, 12

Automatic key, 44

Automatic-mode, 44

B

board
 distribution board, 9
 motherboard, 9

boiler, filling the boiler with water, 21

boiler capacity, 12

box 1 and 2, 38

C

calibration
 additives, detergent, 37
 feed components, 22
 water, milk, milk powder, 35

check routine, carry out, 53

cleaning
 air cleaning, 51
 automatic mixer cleaning (time-controlled), 51
 entering the figures, 48
 mixer, 50
 selecting the options, 49
 settings, 52

cleaning key, 47

compressor, 51

concentration, 34

connect, System-Machine to feeding computer, 31

connecting the mains plug, 21

connection
 additive dispenser, 58
 suction hose, 14
 water, 16

construction parts, 7

D

detergent, enter amount, 52

detergent dosing pump, 59

diagnosis, 39
 calibration, 40
 checking, 40
 interface, 40
 sensors, 39
 valves/motors, 39

dimensions of the automatic feeder, 12

distributing the milk, 26

distribution board, 9

distribution pause, 38

E

earth bonding, 13

earth leak switch, 13

electrical connection, 12
 local, 13

electrical vapour screen, 58

electrode, supply electrode, 26

emptying mixer, 38

extra-portion, 45

F

fault messages, 55
 electrode fault, 55
 emptying mixer, 56
 lack of water, 55
 memory error, 55
 temperature, 55

fly screen, 13, 59

frost protection, 13

frost risk, 54

function table of the Menu key, 42

functioning of the automatic calf feeder, 26
 preparing the milk portions, 26

H

- hand functions, 33
- hand-actuated feeding pump, 11
- heating
 - adjusting the thermostats, 23
 - avoiding measuring errors, 24
 - for milk powder outlet and protection against frost, 25
 - measuring the temperature, 24
 - setting the heating, 23
 - setting the temperature, 24

I

- identification, connect, 15
- installation
 - automatic calf feeder, 21
 - calibrating the feed components, 22
 - checking the jumper in case of relay interface, 21
 - connecting the automatic calf feeder to the mains supply, 21
 - filling the boiler with water, 21
 - filling the milk powder into the powder hopper, 22
- installing the automatic calf feeder, 13
- intermediate mix, 37

K

- keys
 - Automatic, 44
 - Cleaning, 47
 - Menu, 33

L

- lightning protection, 13
- locating the automatic calf feeder, local electrical connection, 13

M

- machine type, machine number, 6
- machine values, 37
- mains plug, connecting, 21
- maintenance, 53
- Menu key, 33
 - calibration, 35

- diagnosis, 39
- hand functions, 33
- portion values, 34

- Menu-key, machine values, 37
- milk portion, preparation, 26
- milk powder, fill in, 22
- milk powder hopper-storage capacity, 12
- milk, concentration, 34
- mixer, automatic cleaning, 50
- mixer afterrun, 37
- mixer cleaning, 52
 - automatic, time-controlled, 51
- motherboard, 9
- mounting
 - the additive dispenser, 58
 - the sucking station, 14
 - the suction bracket, 14

N

- nameplate, machine type, machine number, 6

O

- operating elements, 17
 - keyboard, 17
 - entering the values, 19
 - operational control keys, 18
 - selecting the options, 20
- overvoltage, 13

P

- portion values, 34
- powder outlet, check, 53
- pressure reducer, 16
- priority control, 57

R

- race-way, mounting, 15
- rated frequency, 13
- rated voltage, 13
- restricted mode, 35
 - milk distribution, 26

S

- safety instructions, 5

service, 53

service & maintenance, 53

service and maintenance, 53

- carry out regular check routine, 53
- shutdown, 54

settings

- air cleaning, 52
- cleaning, 52
- detergent, 52
- mixer cleaning, 52

Setup, 27

- different selections in Setup, 27
- function table, 29
- how to make entries, 30

shutdown, 54

signs

- danger signs, 6
- information signs, 6

specifications, automatic calf feeder, 12

suction hose, 14

System-Machine, connect to feeding computer, 31

T

turn-on and turn-off delay, 38

V

version, 41

W

water connection, 12

water heating in the boiler, 10

water pressure, 16

EC DECLARATION OF CONFORMITY

We,

Förster Technik GmbH
Gerwigstr. 25
D-78234 Engen
Tel.: +49- (0)7733-9406-0
Fax: +49-(0)7733-9406-99



declare that our products with the designation:

TAK*-SM2-27-F1	TAP*-SM2-27-F1	VDW*-SM2-27-F1
TAK*-SM2-28-P1	TAP*-SM2-28-P1	VDW*-SM2-28-P1
TAK*-SM2-30-P1	TAP*-SM2-30-P1	VDW*-SM2-30-P1
TAK*-SM2-32-P1		VDW*-SM2-32-P1
TAK*-SM2-38-P1		VDW*-SM2-38-P1

including all accessories, * with chassis size 5

to which this declaration relates are in conformity with the following relevant regulations:

EN 292-1 / 11.91	Basic concepts of general design of machines, part 1
EN 292-2 / 06.95	Basic concepts of general design of machines, part 2
EN 294 / 8.92	Safety clearance for upper limbs
EN 349 / 6.93	Minimum clearance for avoiding crushing upper limbs
EN 50081-1 / 3.93	Norm concerning electromagnetic emissions on residential areas, business districts and industrial areas
EN 50082-1 / 11.97	Norm of the resistance to jamming against line directed disturbances, induced by highfrequency fields above 9 kHz
EN 563 / 08.94, 01.95	Temperatures of touchable surfaces
prEN 1070 / 6.93	Safety of machines, terminology
EN 60204-1 / 11.98	Electrical components of machines

per the provisions of Council Directives 89/392/EEC, Annex II A, 89/336/EEC, 73/23/EEC and 93/68/EEC.

Date: 01. 01. 2002

A handwritten signature in black ink, appearing to read 'W. Latz', positioned above a horizontal dotted line.

Wolfgang Latz

A handwritten signature in black ink, appearing to read 'A. Steiner', positioned above a horizontal dotted line.

Alfred Steiner

Signatory: M. Latz, Head of Production Management
 M. Steiner, Head of Production, Department Electrical Components