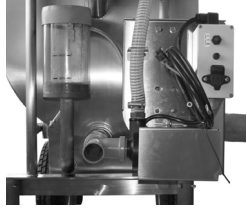

<b>FÖRSTER TECHNIK®</b>  <b>S21.1e</b>	<b>Service info</b>	Dosing pump	
	<b>Re:</b>	Milk trolley MilchMobil	
	<b>Date</b>	26th of May 2010	
Page 1 out of 12	<b>Retrofitting</b>		

## Dosing pump

### 1 Introduction

These mounting instructions put you in the position to retrofit the dosing pump safely as intended.

- > Please read these mounting instructions carefully before mounting the dosing pump.
- > Keep these mounting instructions readily available at all times.
- > Observe all of the warnings and safety instructions in these mounting instructions at all times.
- > Observe the original operating manual of the milk trolley „MilchMobil“ and particularly the chapter „For your safety“.

### 2 Zu Ihrer Sicherheit

#### 2.1 Zielgruppe

Solely trained service technicians are authorised to mount the dosing pump.

##### 2.1.1 Necessary qualifications of the service technician

Service technicians are electricians with appropriate qualifications, i.e. they are able to assess the work assigned to them and detect potential risks on the basis of their technical training as well as their knowledge of the relevant standards. This also includes the knowledge of relevant accident prevention

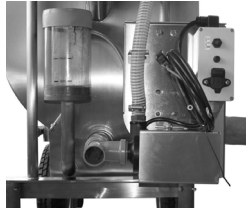
<b>FÖRSTER TECHNIK®</b>  <b>S21.1e</b>	<b>Service info</b>	Dosing pump	
	<b>Re:</b>	Milk trolley MilchMobil	
	<b>Date</b>	26th of May 2010	
Page 2 out of 12	<b>Retrofitting</b>		

regulations, generally accepted safety regulations, EU guidelines and country-specific standards and provisions.

## 2.2 Intended use of the dosing pump

The dosing pump is to be used exclusively for the dosage of liquid feed for young animals in combination with the milk trolley „MilchMobil“ or similar products.

## 2.3 Improper use of the dosing pump

The dosing pump must not be used for the preparation, heating, dosage, portioning and transport of liquid food for consumption by humans.

## 2.4 Safety signs on the product

The safety signs on the product are an important part of the safety concept and help prevent accidents.

They indicate danger areas at the machine and warn against residual risks.

Keep all safety signs completely in legible condition and renew them if they become unreadable.



### **Not suitable for food!**

The dosing pump is suitable exclusively for animal feed. Do not therefore use the dosing pump for food intended for consumption by humans (e.g. consumer milk).

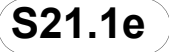
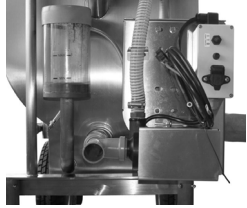
 	<b>Service info</b> Dosing pump	
	<b>Re:</b> Milk trolley MilchMobil	
	<b>Date</b> 26th of May 2010	
Page 3 out of 12	<b>Retrofitting</b>	

	<p><b>Do not spray-wash!</b></p> <p>Water (liquids) can damage electrical components.</p> <ul style="list-style-type: none"> <li>• Do not spray-wash the dosing pump. Do not use any high-pressure cleaners or similar equipment either.</li> <li>• To clean the dosing pump, wipe the respective components exclusively with a damp cloth.</li> </ul>
---	--

## 2.5 Indication of hazards

Dangers are indicated by a key word and a corresponding sign, depending on the severity and probability.

	<p><b>Danger!</b></p> <p>For an imminent danger, resulting in serious injuries or death.</p>
---	--

	<p><b>Warning!</b></p> <p>For a potentially dangerous situation which may cause serious injuries or even death.</p>
---	---

	<p><b>Caution!</b></p> <p>For a potentially dangerous situation which may cause minor injuries or material damage.</p>
---	--

<p><b>Attention</b></p>	<p>For a potentially harmful situation in which the product or an item can become damaged within its environment.</p>
-------------------------	---

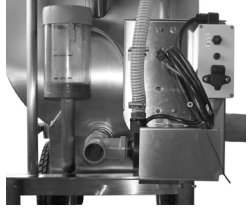
<b>FÖRSTER TECHNIK®</b>  <b>S21.1e</b>	<b>Service info</b>	Dosing pump	
	<b>Re:</b>	Milk trolley MilchMobil	
	<b>Date</b>	26th of May 2010	
Page 4 out of 12	<b>Retrofitting</b>		

<b>Note</b>	For application notes and other useful information.
-------------	---

However, it is just as important to observe any other notes and information which are not highlighted to avoid failures which, in turn, may cause direct or indirect injuries or material damage.

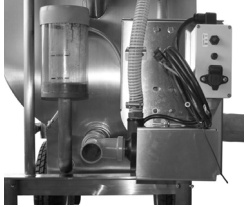
<b>FÖRSTER TECHNIK®</b>  <b>S21.1e</b>	<b>Service info</b>	Dosing pump	
	<b>Re:</b>	Milk trolley MilchMobil	
	<b>Date</b>	26th of May 2010	
Page 5 out of 12	<b>Retrofitting</b>		

### 3 Scope of delivery

The scope of delivery of the dosing pump is as follows:

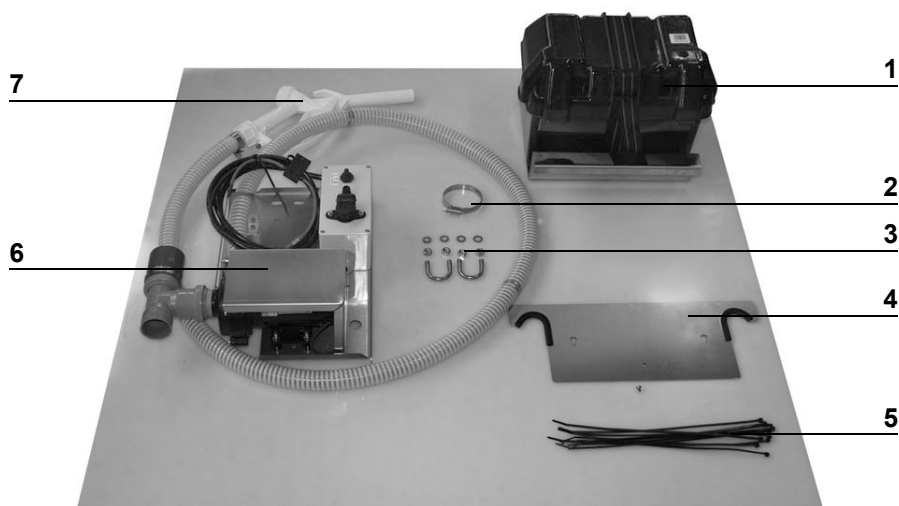

1	Battery box with rechargeable battery + standard 25 A motor vehicle blade fuse
2	Hose clip
3	U-bolt with washers and nuts
4	Mounting plate for battery box with screw
5	Cable clip
6	Pump with T-fitting
7	Filling pistol with hose

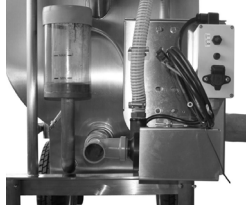
<b>FÖRSTER TECHNIK®</b>  <b>S21.1e</b>	<b>Service info</b>	Dosing pump	
	<b>Re:</b>	Milk trolley MilchMobil	
	<b>Date</b>	26th of May 2010	
Page 6 out of 12	<b>Retrofitting</b>		

## 4 Mounting the dosing pump to the MilchMobil

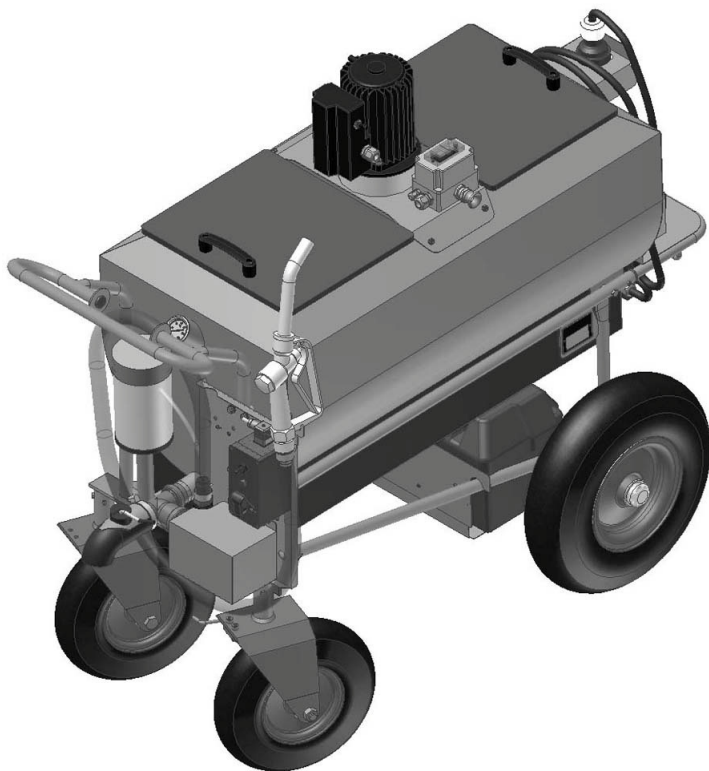

Before mounting the dosing pump, make sure that

- > all of the electrical connections of the MilchMobil are safely disconnected from the mains.
- > the MilchMobil is staying on a firm and level surface and the parking brake is engaged.

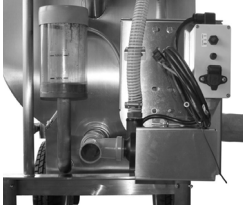
<b>FÖRSTER TECHNIK®</b>  <b>S21.1e</b>	<b>Service info</b>	Dosing pump	
	<b>Re:</b>	Milk trolley MilchMobil	
	<b>Date</b>	26th of May 2010	
Page 7 out of 12	<b>Retrofitting</b>		



**Caution!**

Injuries to the locomotor system may be caused by the weight and installation position of the rechargeable battery. To avoid this, observe the weight of the assembly in the section “Lead-gel rechargeable battery” auf Seite 46 and the industrial safety regulations.

For mounting, proceed as follows:

1. Loosen the clip at the outlet tap.
2. Remove the outlet tap.
3. Mount the dosing pump.

**Note**

Use a grease/lubricant so that the hose can be more easily moved from the guide of the stainless steel tank.

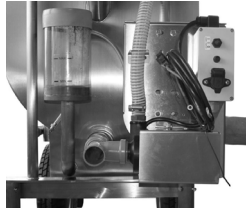
<b>FÖRSTER TECHNIK®</b>  <b>S21.1e</b>	<b>Service info</b>	Dosing pump	
	<b>Re:</b>	Milk trolley MilchMobil	
	<b>Date</b>	26th of May 2010	
Page 8 out of 12	<b>Retrofitting</b>		

- Place the supplied U-bolts from the rear around the right handle bar and run them through the plate (see illustration).

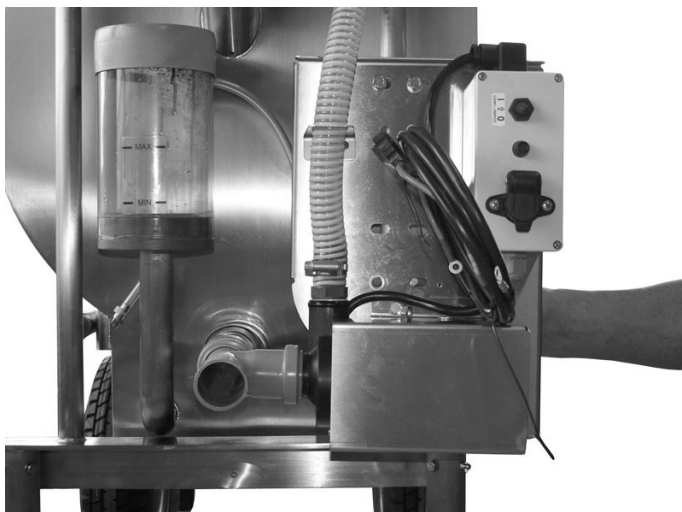

- Tighten the U-bolts with the supplied washers and nuts evenly.

<b>Attention</b>	Make sure that the dosing pump is mounted in a level position.
------------------	--

- Tighten the loose clip at the connection of the stainless steel tank to the hose of the dosing pump.
- Connect the outlet tap to the T-fitting and tighten the clip with moderate pressure.

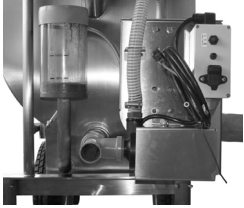

<b>FÖRSTER TECHNIK®</b>  <b>S21.1e</b>	<b>Service info</b>	Dosing pump	
	<b>Re:</b>	Milk trolley MilchMobil	
	<b>Date</b>	26th of May 2010	
Page 9 out of 12	<b>Retrofitting</b>		

8. Run the cable of the dosing pump around the right handle bar downward and secure it with the two supplied cable clips (see illustration).



9. Run the cable of the dosing pump along the chassis of the MilchMobil towards the rechargeable battery and secure it with the supplied cable clips (see illustration).



<b>Note</b>	Run the end of the cable as a downward bowed arc.
-------------	---

10. Remove the rear plate of the battery box.

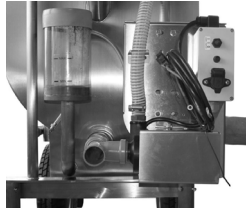
<b>FÖRSTER TECHNIK®</b>  <b>S21.1e</b>	<b>Service info</b>	Dosing pump	
	<b>Re:</b>	Milk trolley MilchMobil	
	<b>Date</b>	26th of May 2010	
Page 10 out of 12	<b>Retrofitting</b>		

11. Hang this plate into the chassis of the MilchMobil (see illustration).

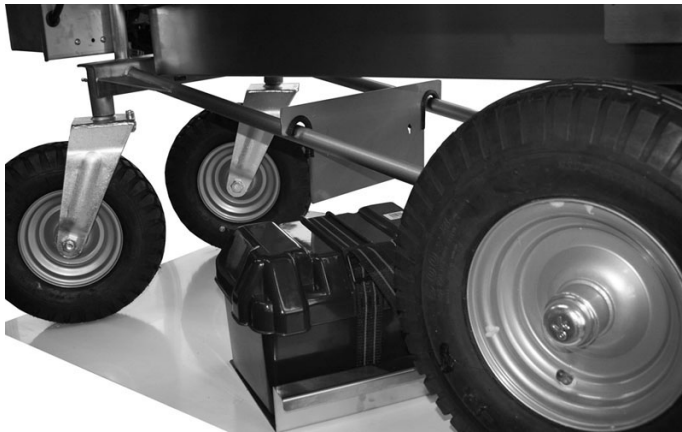

**Caution!**

Injuries to the locomotor system may be caused by the weight and installation position of the rechargeable battery. To avoid this, observe the weight of the assembly in the section "Lead-gel rechargeable battery" auf Seite 46 and the industrial safety regulations.

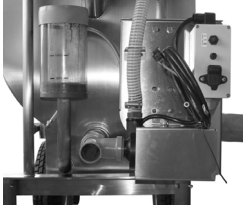
<b>FÖRSTER TECHNIK®</b>  <b>S21.1e</b>	<b>Service info</b>	Dosing pump	
	<b>Re:</b>	Milk trolley MilchMobil	
	<b>Date</b>	26th of May 2010	
Page 11 out of 12	<b>Retrofitting</b>		

12. Hang the battery box without lid into the connecting tube of the rigid axle of the MilchMobil (see illustration).



13. Pull the battery box upward by means of the lashing strap until it hangs horizontally in the chassis of the MilchMobil (see illustration).

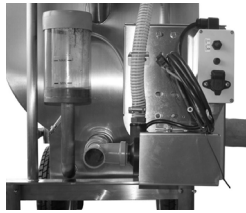

14. Screw the battery box and the suspended plate together by means of the supplied screw.

<b>FÖRSTER TECHNIK®</b>  <b>S21.1e</b>	<b>Service info</b>	Dosing pump	
	<b>Re:</b>	Milk trolley MilchMobil	
	<b>Date</b>	26th of May 2010	
Page 12 out of 12	<b>Retrofitting</b>		

15. Tighten up the other two screws of the battery box.
16. Connect the cable of the dosing pump to the rechargeable battery according to the supplied wiring diagram.
17. Close the battery box by means of the lid.
18. Tighten the lashing strap to fasten the rechargeable battery.
19. Carry out a functional test of the dosing pump.

<b>Attention</b>	To do so, observe the chapters „MilchMobil components“ and „Putting the MilchMobil into and removing it from service“ contained in the original operating manual of the MilchMobil.
------------------	---