



| | | | |
|--|----------------------|------------------------|---|
|   | Mounting info | Spare part kit 2 (SP2) |  |
| | Machines | Vario and Compact | |
| | Date | May 1st, 2014 | |
| Page 1 out of 8 | Topic | Servicing | |

Spare part kit 2 (ET2)

1 Introduction

A service message appears in the automatic feeder display every 4 months. This message indicates the maintenance (rule service) that must be performed. Compliance with these maintenance intervals is the only way to ensure the long life and reliability of the automatic feeder.

Go to **Setup > Service > Last Service** and check when the last rule service was performed or go to **Setup > Service > Next Service** to determine when the next rule service is due.

The following rule services (RS) have been defined:

- RS1 must be performed every 4 months.
- RS2 must be performed every 12 months.
- RS3 must be performed every 36 months.

Depending on the service type to be performed, different spare part sets are required. These mounting instructions take the spare part set 2 (SP2) into consideration. For servicing intervals and spare part set assignment, please refer to the picture below.

Mounting info

Spare part kit 2 (SP2)

Machines

Vario and Compact

Date



May 1st, 2014

Topic

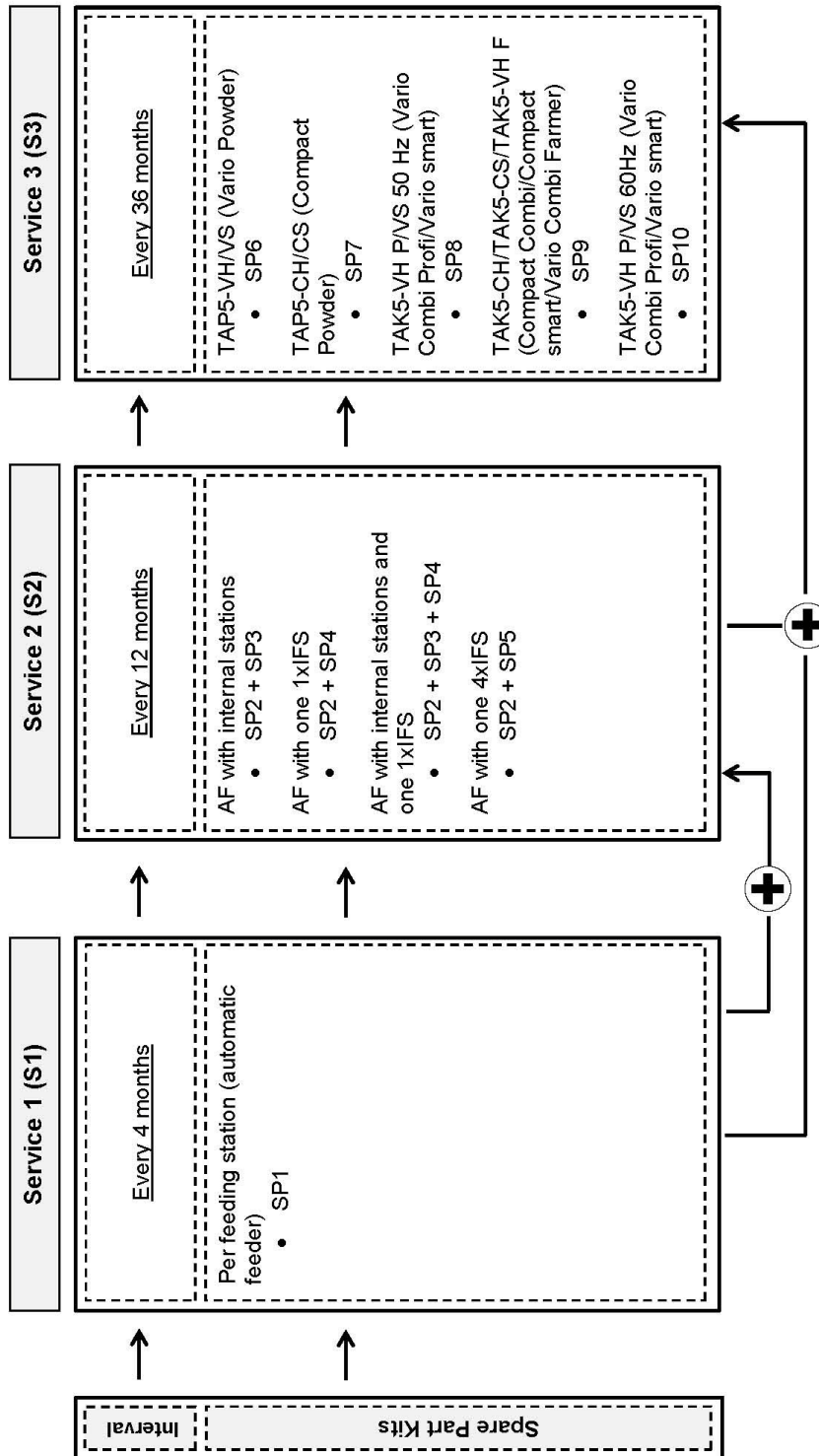
Servicing



Caption: SP = Spare Part Kit; AF = Automatic Feeder; IFS = Intelligent Feeding Station

| | | | |
|---|----------------------|------------------------|---|
| FÖRSTER TECHNIK®  S29.2e | Mounting info | Spare part kit 2 (SP2) |  |
| | Machines | Vario and Compact | |
| | Date | May 1st, 2014 | |
| Page 3 out of 8 | Topic | Servicing | |

1.1 Who is allowed to service the automatic feeder?

Only trained service technicians are authorized to service the automatic feeder.

- > Carefully read all these mounting instructions before servicing the automatic feeder.
- > These mounting instructions must be kept readily available at all times.
- > Observe all of the warnings and safety instructions in these mounting instructions.
- > In addition, observe all of the relevant warnings and safety instructions in the original operating manual of the automatic feeder.

1.2 Necessary qualification of service technicians

Service technicians are specialists with the appropriate qualifications. They are able to assess the work assigned to them and detect potential risks on the basis of their technical training as well as their knowledge of the relevant standards. They are familiar with the relevant accident prevention regulations, generally accepted safety regulations and country-specific standards and provisions.

2 For your safety

⚠ WARNING When using electric appliances, basic precautions should always be followed.

Read and observe all the relevant safety instructions contained in the operating manual of the automatic feeder.

| | | | |
|--|----------------------|------------------------|---|
| FÖRSTER TECHNIK® S29.2e | Mounting info | Spare part kit 2 (SP2) |  |
| | Machines | Vario and Compact | |
| | Date | May 1st, 2014 | |
| Page 4 out of 8 | Topic | Servicing | |

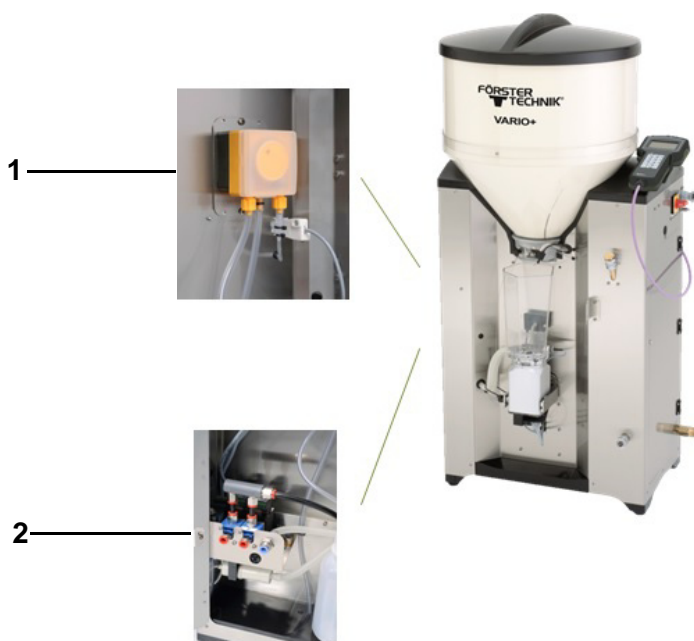

3 Which assemblies are affected by SP2?

Detergent pump and shut-off valves



1 Detergent pump



2 Shut-off valve

| | | | |
|--|----------------------|------------------------|---|
|  S29.2e | Mounting info | Spare part kit 2 (SP2) |  |
| | Machines | Vario and Compact | |
| | Date | May 1st, 2014 | |
| Page 5 out of 8 | Topic | Servicing | |

4 Scope of delivery SP2

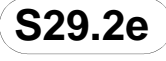

The article number of the complete **SP2** is: **48324**.

| | Article no. | Designation | Amount | Position no. |
|---|-------------|---|--------|--------------|
|  | 41350 | hose 4.8x1.6mm PS 140Ph L:14cm dispenser Liquid-DSP | 1x | 6 |
|  | 98223 | O-ring 26.0x1.2 NBR 70 Shore (box valve) | 2x | 30 |
|  | 45180 | valve component - dia- phragm V01 NBR | 1x | 21 |
|  | 91626 | O-ring 16.0x2.5mm NBR 70 Shore | 4x | 51 |
|  | 40444 | O-ring 11.0x2.5mm NBR 70 Shore | 1x | 57 |

| | | | |
|--|----------------------|------------------------|---|
|   | Mounting info | Spare part kit 2 (SP2) |  |
| | Machines | Vario and Compact | |
| | Date | May 1st, 2014 | |
| Page 6 out of 8 | Topic | Servicing | |

5 What service procedures are to be carried out for RS2?

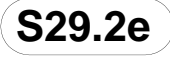
- Visual inspection
 - Check the mixer for cracks and damages.
 - Check the powder hopper for cracks and damages.
 - If available: check the hoses of the IFS feeding station, of the milk tank and the detergent pump.
- Check the level of the detergent.
- Calibrate the feed components, the detergent, the additives, hose pumps and animal scales (if available).
- Carry out the following cleaning processes:
 - With the Powder version: mixer cleaning
 - With the Combi and fresh milk version: mixer and heat exchanger cleaning as well as sponge cleaning
- Check the error counter in **Main menu > Diagnosis > Control**.
- Carry out a software update.
- Perform a basic cleaning of the shut-off valves.
 - Remove the shut-off valves and dismantle them.
 - Check the valves for proper function. If there are deposits, perform a manual cleaning.
- Replace the parts contained in the spare part set and mount them according to the mounting position below.

| | | | |
|--|----------------------|------------------------|---|
|   | Mounting info | Spare part kit 2 (SP2) |  |
| | Machines | Vario and Compact | |
| | Date | May 1st, 2014 | |
| Page 7 out of 8 | Topic | Servicing | |

Note: In the dealer area of the Förster-Technik website a video is available which schematically shows the individual steps required for the replacement of the parts included in the spare part sets.

6 Mounting position of the spare parts

6.1 Assembly „Detergent pump“

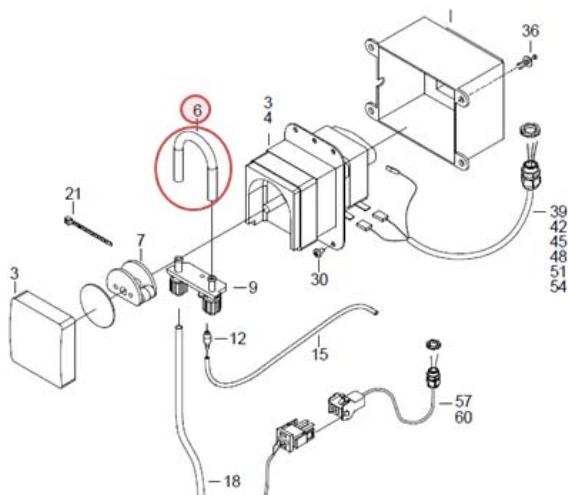

Mounting info

Spare part kit 2 (SP2)

Machines

Vario and Compact

Date

May 1st, 2014

Topic

Servicing



6.2 Assembly „Shut-off valves“

