

stop valve / feeding station valve (regular equipment)

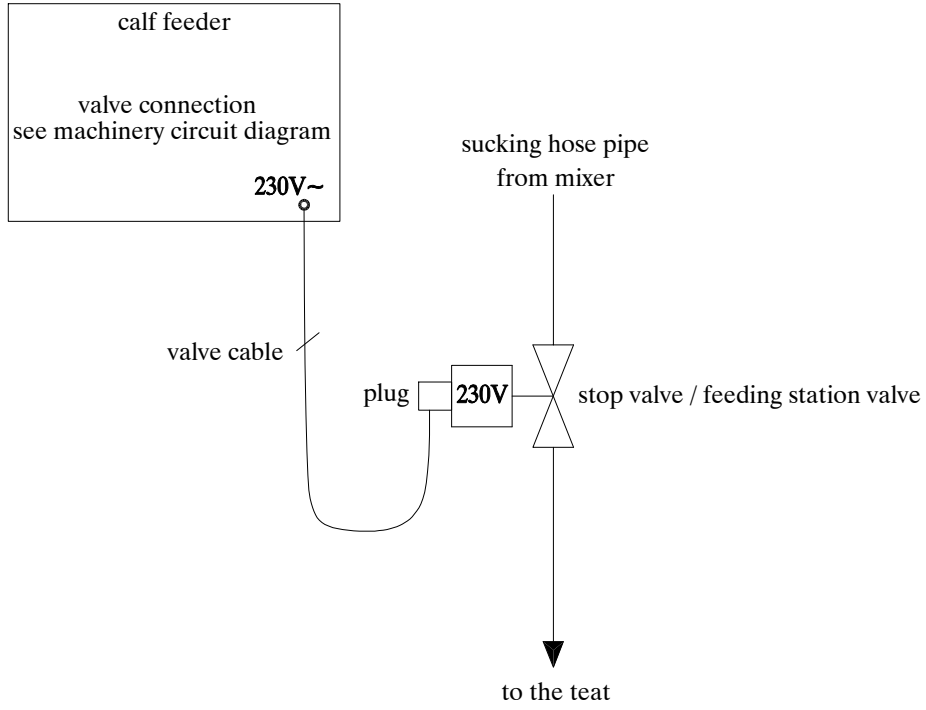

stop valve / feeding station valve with gradient control

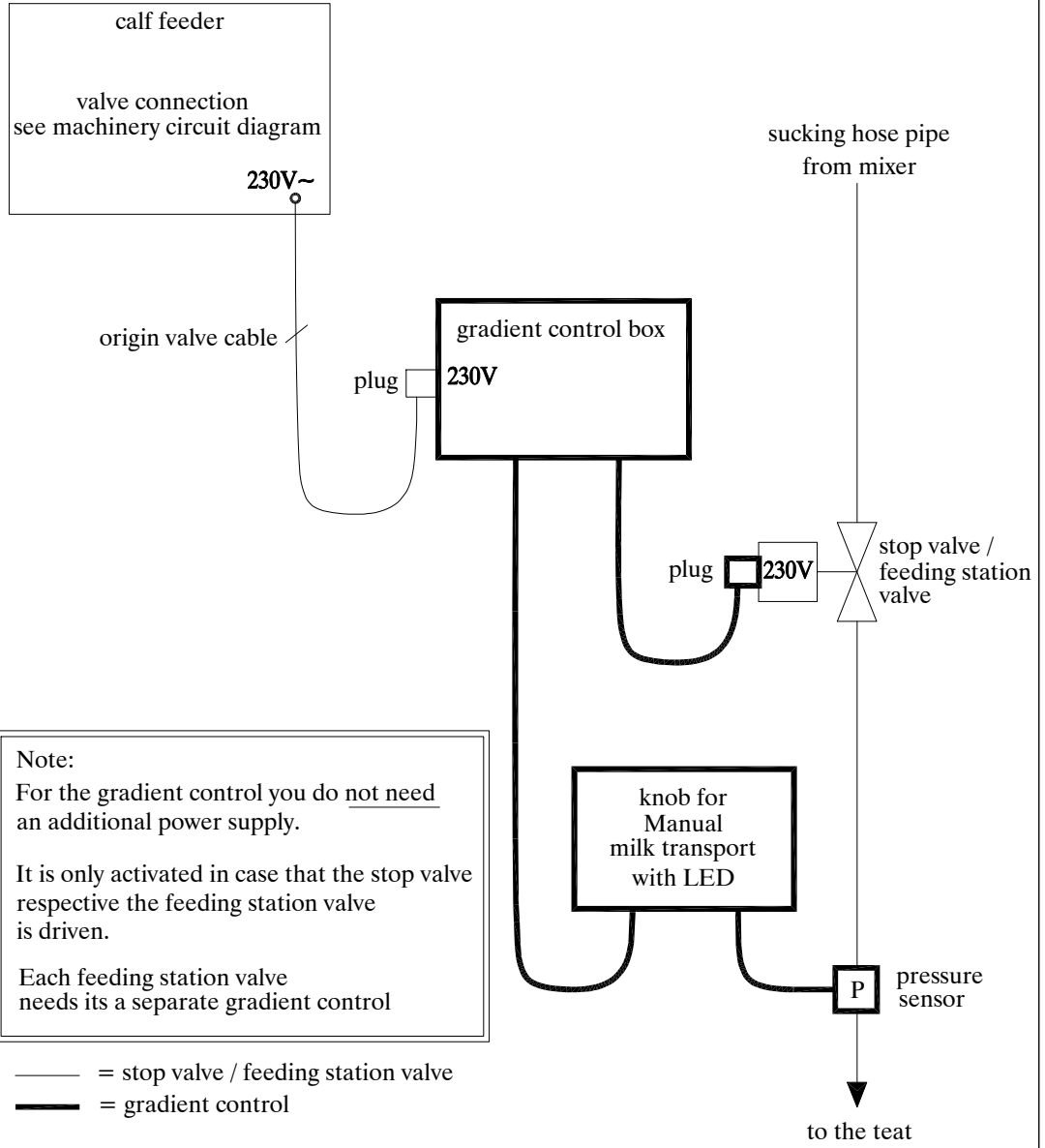

Note:
 For the gradient control you do not need an additional power supply.
 It is only activated in case that the stop valve respective the feeding station valve is driven.
 Each feeding station valve needs its a separate gradient control

— = stop valve / feeding station valve
 — = gradient control

				gradient control for SM1 / SA2 / SA2 Plus		Förster Technik GmbH		Zeichnungs-Nr. PL10104		Blatt 1	
						gezeichnet		Versions-Nr. a		von 2 Blätter	
Änderung				Ind. Datum Name		Datum 18.10.2001		Gültig ab:			
						Name jr		Gültig bis:			

=GS1 gradient control

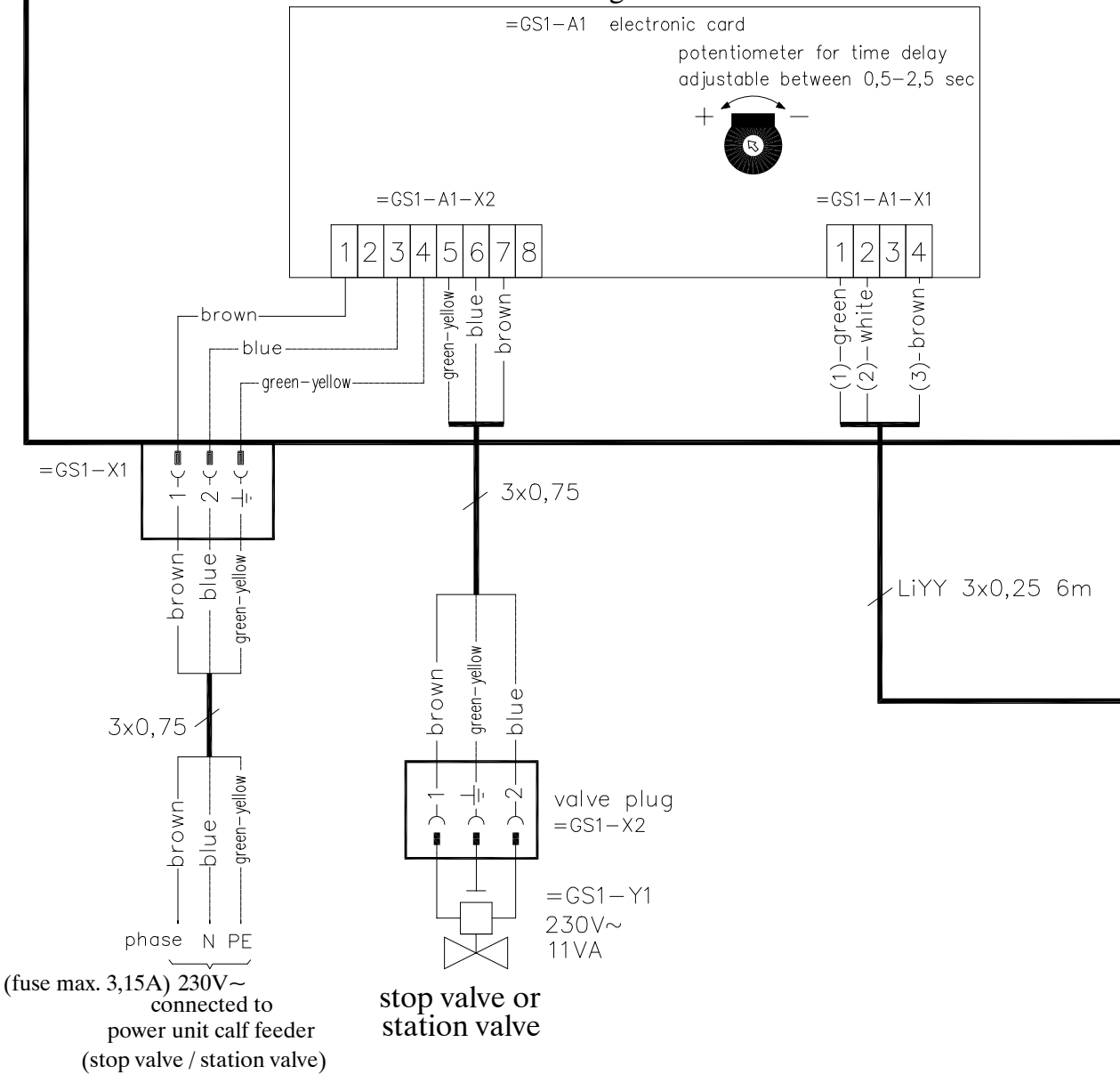

=MT1 manual milk transport

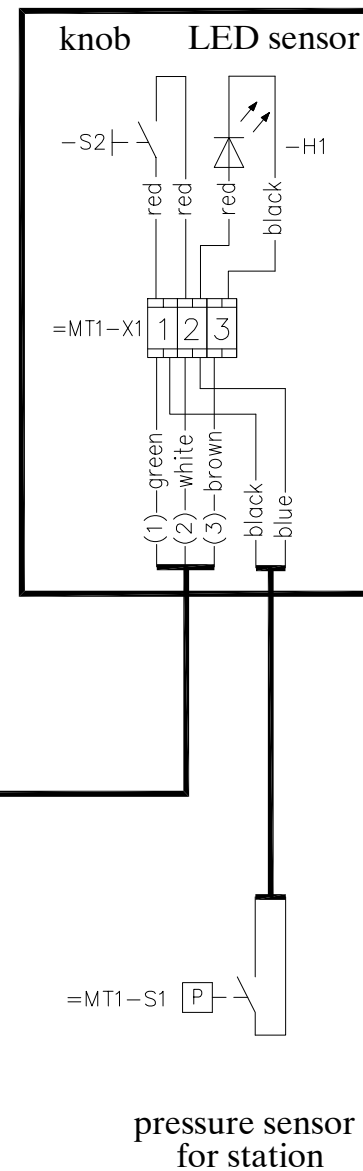

				gradient control for SM1 / SA2 / SA2 Plus		Förster Technik GmbH		Zeichnungs-Nr. PL10104		Blatt 2	
								Versions-Nr. a			
Änderung				Ind. Datum Name		gezeichnet		Datum 18.10.2001		Gültig ab:	
						Name jr		Gültig bis:		von 2 Blätter	